

1. See CCS Installation Manual for pinout details
2. Evaporator switch must be type that is closed when temp is above freezing limit
3. Pressure switch must be type that is closed when pressure is between high and low limits
4. Heat valve controller is a Ray Allen trim servo, five-wire connection.
5. All grounds should return to same ground block.

▽ Common ground block

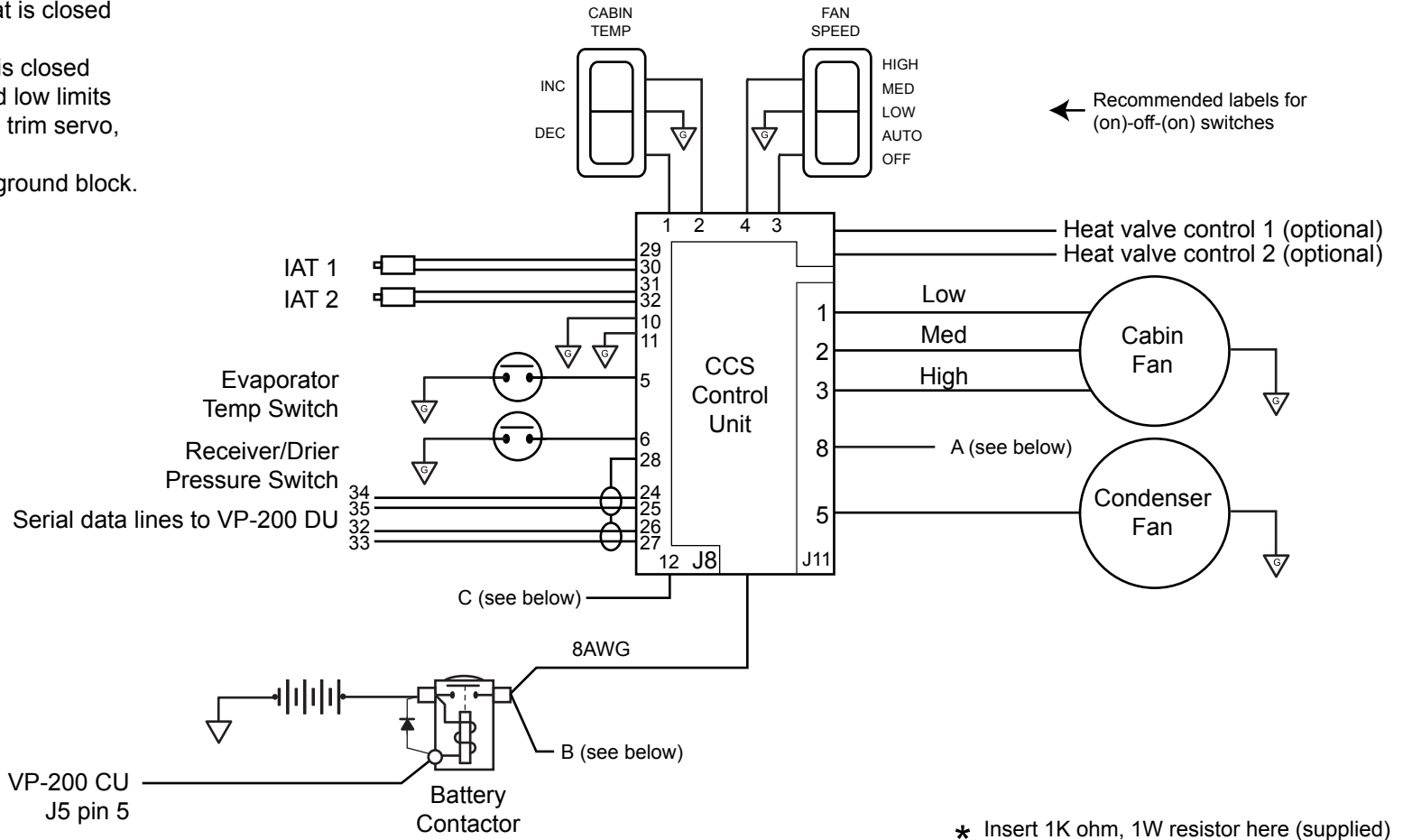

VP-200 CU
J5 pin 5

Battery
Contactor

* Insert 1K ohm, 1W resistor here (supplied)

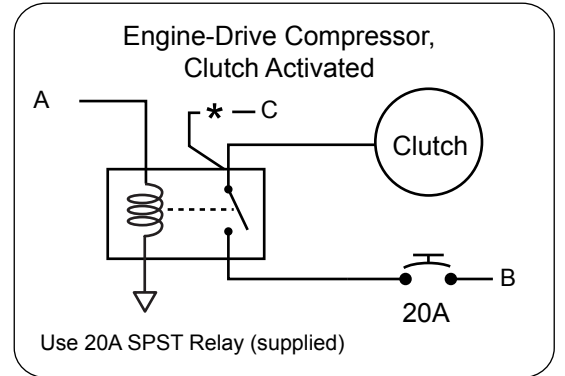
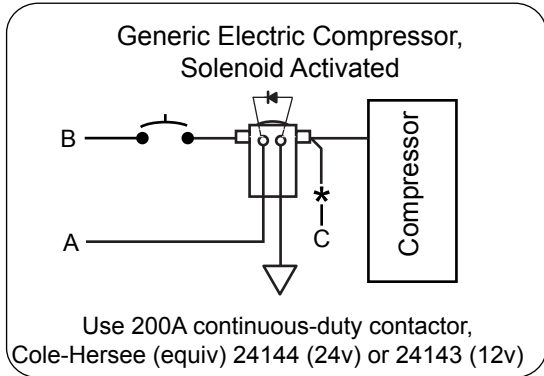
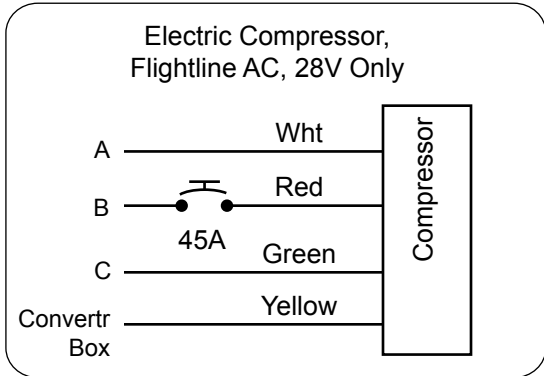

Note: Follow recommendations of AC manufacturer for wiring, relay, and circuit protection sizing for compressor.