



Electronic Circuit Breaker System

**VP-X**



**Installation and Operating Manual**

October 12, 2010

Current as of  
software version 1.4

# Table of Contents

1	Introduction.....	4
1.1	Welcome to Vertical Power! .....	4
1.2	Vertical Power Terms .....	4
1.3	Other Reference Documents.....	5
2	Electrical System Basics.....	5
2.1	Alternator Operation.....	6
2.2	Wire Sizes and Circuit Protection.....	7
2.3	Grounding.....	7
2.4	Switch Nomenclature.....	8
2.5	Alternator Current Sensing .....	8
3	Vertical Power Overview .....	9
3.1	Installation Overview.....	9
3.2	System Overview.....	9
3.3	Supported Bus Architecture.....	9
4	Planning.....	10
4.1	EFIS .....	10
4.2	Wiring Harness .....	10
4.3	Tools and Other Stuff .....	10
4.4	VP-X Connectors.....	10
4.5	Installing and Removing Power Connector Terminals.....	11
4.5a	Installing terminals .....	11
4.5b	Removing terminals.....	13
4.6	Alternator and Voltage Regulator Considerations.....	14
4.6a	Over-voltage Planning.....	15
4.6b	Low-voltage Planning.....	15
4.7	Landing Light Wig-Wag (Pulsing) Considerations.....	15
4.8	Electronic Ignition Considerations .....	15
4.9	Load Planning Worksheet.....	16
4.9a	System tab.....	16
4.9b	VP-X tab .....	16
4.9c	What if I run out of power pins?.....	18
4.9d	What if I run out of switch inputs? .....	18
5	Installation .....	18
5.1	Pre-Installation Tasks .....	18
5.2	VP-X Installation.....	19
5.3	Wiring Harness Construction .....	20
5.4	Backbone Wiring .....	21
5.5	Master Contactor Wiring .....	21
5.6	Starter Contactor Wiring.....	22
5.7	Starter Annunciator Wiring .....	23
5.8	Other Contactor Wiring .....	24
5.9	Alternator Wiring.....	24
5.9a	Primary Alternator (B&C External Regulator).....	24
5.9b	Primary Alternator (Plane Power) .....	25
5.9c	Backup Alternator (B&C 20 Amp).....	26
5.9d	Backup Alternator (B&C 8 Amp).....	26
5.10	Primary EFIS Wiring – Power and Data Connections .....	27

5.11	Ground Wiring.....	27
5.12	General Power Wiring.....	28
5.13	Trim System Wiring .....	28
5.13a	Pitch Trim Wiring.....	30
5.13b	Roll Trim Wiring.....	30
5.13c	TruTrak Auto Trim Module.....	31
5.13d	Co-Pilot Disconnect Switch.....	31
5.13e	Wiring a third trim motor .....	31
5.14	Flap System Wiring .....	32
5.14a	Flaps System With Limit Switches.....	33
5.15	Panel Switches Wiring.....	33
5.15a	Standard Switches.....	34
5.15b	Alternator switch .....	35
5.15c	Boost pump switch .....	35
5.15d	Dimmer wiring.....	36
5.15e	Mag switch wiring .....	36
5.16	P-Mag wiring .....	36
5.17	Backup Circuits .....	37
5.17a	Backup Circuit Considerations .....	37
5.17b	Backup Method B .....	38
5.17c	Backup Method C .....	39
5.17d	Do not wire backups this way.....	39
5.17e	Aft-mounted battery considerations .....	39
5.18	Aux Battery Wiring and Voltage Measurement .....	40
5.19	Items you don't have to wire to the EFIS .....	40
5.20	Retractable Gear Wiring .....	41
5.21	Testing Individual Circuits .....	41
6	Configure the System Settings.....	42
6.1a	GRT HX: .....	43
6.1b	MGL: .....	43
6.1c	AFS:.....	43
6.1d	Switch Input Verification .....	43
6.1e	Avionics, Lights, etc. ....	44
6.1f	Alternator – Primary and Backup .....	44
6.1g	Starter.....	44
6.1h	Trim .....	44
6.1i	Flaps.....	45
6.1j	Wig-Wag.....	48
6.1k	Aux battery input .....	48
6.1l	Starter Annunciator Input .....	48
6.1m	Export Settings.....	48
6.1n	Import Settings.....	49
7	Ground Test .....	49
7.1	Testing without engine running .....	49
7.2	Testing while engine running .....	49
8	Flight Test.....	50
8.1	Notes about first flight .....	50
8.2	VP-X system checkout .....	50
9	Troubleshooting.....	51

9.1	Flap Configuration.....	51
9.2	Electrical Configuration.....	52
9.3	Trim faults .....	52
10	VP-X System Operation .....	53
10.1	Power On and Off.....	53
10.2	EFIS Electrical System Page .....	53
10.3	Other VP-X functions .....	53
10.4	VP-X Configuration.....	54
10.5	Turning electrical devices on and off .....	54
10.6	Trim and flap operation .....	54
10.6a	Trim switch fault detection on startup.....	54
10.6b	Runaway trim and flaps .....	54
10.6c	Trim and flap operation with a faulty position sensor.....	55
10.6d	Max Flap Speed Functions .....	55
10.7	Landing Light Wig-Wag.....	55
10.8	Circuit Faults .....	56
10.9	Starter Disable .....	56
10.10	Low-Voltage Alarm.....	56
10.11	Over-Voltage Alarm .....	56
10.12	Battery Contactor Failure .....	56
10.13	Backup Circuits .....	56
10.14	Data Comm Loss .....	57
10.15	Software Updates.....	57
11	Appendix A – Pinout Diagram .....	58
12	Appendix B – Wiring Harness Contents .....	59
13	Appendix C - VP-X System Annunciators .....	60
14	Appendix D – MGL to PC Interface Cable .....	61

## Important Notice

**This manual contains important information that may affect the safety of your aircraft. Do not fly the aircraft until you fully understand the installation and operating instructions, and all of the pre-flight checks have been successfully completed.**

Read the Warranty / Agreement below. There is information in the Warranty / Agreement that may alter your decision to install this product. **If you do not accept the terms of the Warranty / Agreement, do not install this product.** The product may be returned for a refund if you do not accept the terms of the Limited Warranty / Agreement.

Vertical Power Inc. is not liable or responsible for a pilot's action or any situation that results in personal injury, property damage, missed commitments, lack of use of an aircraft or any expenses incurred due to: product failure, inaccuracy in displayed data or text files, display or display format issues, software bugs or problems, upgrade or customization issues, misinterpretation of the display, warning and/or limit settings, calibration problems, installation issues (leaks, mis-wiring, obstructions, damage to aircraft or components, incorrect installation of any parts, wrong parts, parts that don't fit, etc.) or any other issues related to the installation or operation of this product. All of the above are solely the pilot's and/or installer's responsibility. The pilot must understand the operation of this product before flying the aircraft. The pilot will not allow anyone to operate the aircraft that does not know the operation of this product. The pilot will keep the VP-X Operating Instructions in the aircraft at all times.

By installing this product, the aircraft owner/pilot and installer agree to hold Vertical Power Inc. harmless and in no way responsible for monetary compensation, including punitive damages for any incident, harm and/or damage associated with this product (including but not limited to the ones listed above). If you do not agree to the above, **DO NOT INSTALL THIS PRODUCT.** The pilot, owner and/or installer may want to obtain an appropriate insurance policy before installing this product. If you do not have the skills, knowledge, tools, equipment or facility, to perform and determine the installation of this product is safe, reliable and accurate and to determine this product is operating properly after installation, **DO NOT INSTALL THIS PRODUCT.** If the owner/pilot and/or installer are unwilling to take the responsibility for the installation and operation of this product, **DO NOT INSTALL THIS PRODUCT.** This product may be returned for a refund by contacting Vertical Power Inc.

**The pilot must understand the operation of this product before flying the aircraft.** Do not allow anyone to operate the aircraft that does not know the operation of this product. Keep the Operating Instructions in the aircraft at all times. The ability for this product to correctly control electronic components and detect a problem is directly related to the pilot's ability to properly install the system, program proper configurations and limits, and the pilot's interpretation and observation skills.

It is possible for any system to fail thereby disabling electronic components or displaying inaccurate high, low or jumpy readings. Therefore, you must be able to recognize a system failure and you must be proficient in operating your aircraft safely in spite of a system failure. **IT IS THE BUILDER AND/OR PILOT'S RESPONSIBILITY TO DETERMINE THE APPROPRIATE LEVEL OF BACKUP AND REDUNDANT SYSTEMS NEEDED FOR SAFE OPERATION OF THE AIRCRAFT.** If you do not have this knowledge or skill, contact the FAA, a certified aircraft mechanic, or a local flight instructor for training prior to building or flying the aircraft with this system.

Do not allow anyone who is not qualified to modify the calibration or configuration data. If setup or calibration data is inadvertently or improperly changed, you could get inaccurate readings that may lead to improper operation of the aircraft, flaps, trim, starter, landing gear, or engine. This could result in an unsafe configuration of the control surfaces, engine damage and/or an emergency situation.

Before flying the aircraft verify the instrument markings displayed on the system are accurate with your POH for every function displayed. Verify that each electrical device is configured correctly and behaves appropriately. All data must be verified by the pilot before it is used.

Before starting the installation, make sure that your planned installation will not interfere with the proper operation of any controls. The installer should use current aircraft standards and practices to install this product. Refer to AC 43.13-2A, Acceptable Methods, Techniques, and Practices - Aircraft Alterations and AC 43.13-1B, Acceptable Methods, Techniques, and Practices--Aircraft Inspection and Repair.

The VP-X is an experimental system limited to use in experimental aircraft. Not approved for use in aircraft with FAA or foreign type certificates.

## **LIMITED WARRANTY / AGREEMENT**

Vertical Power Inc. (“VP”) warrants its aircraft monitoring and electrical control system and system components to be free from defects in materials and workmanship for a period of three years after the retail invoice date. VP will repair or replace any system components under the terms of this Warranty provided the item is returned to VP prepaid. This Warranty shall not apply to any unit or component that has been repaired or altered by any person other than VP, or that has been subjected to misuse, abuse, accident, incorrect wiring, or improper or unprofessional installation by any person. **THIS WARRANTY DOES NOT COVER ANY REIMBURSEMENT FOR ANYONE'S TIME FOR INSTALLATION, REMOVAL, ASSEMBLY OR REPAIR.** VP reserves the right to determine the reason or cause for warranty repair.

1. This Warranty does not extend to any engine, machine, aircraft, boat, vehicle or any other device to which the VP system may be connected, attached, or used with in any way.
2. **THE REMEDIES AVAILABLE TO THE PURCHASER ARE LIMITED TO REPAIR, REPLACEMENT, OR REFUND OF THE PURCHASE PRICE OF THE PRODUCT, AT THE SOLE DISCRETION OF VP. CONSEQUENTIAL DAMAGES, SUCH AS DAMAGE TO THE ENGINE OR AIRCRAFT, ARE NOT COVERED, AND ARE EXCLUDED. DAMAGES FOR PHYSICAL INJURY TO PERSON OR PROPERTY ARE NOT COVERED, AND ARE EXCLUDED.**
3. VP is not liable for expenses incurred by the purchaser or installer due to VP updates, modifications, improvements, upgrades, changes, notices or alterations to the product.
4. The pilot must understand the operation of this product before flying the aircraft. Do not allow anyone to operate the aircraft that does not understand the operation of the system. Keep the operating manual in the aircraft at all times.
5. VP is not responsible for shipping charges or damages incurred during Shipment, except for situations where the system fails away from the aircraft’s home base and the pilot is unable to safely fly the aircraft, at which time VP shall, at VP’s sole discretion, pay only one-way shipping charges to the purchaser (US 48 states only).
6. No one is authorized to assume any other or additional liability for VP in connection with the sale of VP products.
7. **IF YOU DO NOT AGREE TO ACCEPT THE TERMS OF THIS WARRANTY, YOU MAY RETURN THE PRODUCT FOR A FULL REFUND. IF YOU DO NOT AGREE TO ACCEPT THE TERMS OF THIS WARRANTY, DO NOT INSTALL THE PRODUCT.**
8. This warranty is made only to the original purchaser and is not transferable. **THIS WARRANTY IS IN LIEU OF ALL OTHER WARRANTIES OR OBLIGATIONS, EXPRESS OR IMPLIED, ORAL OR WRITTEN. VP EXPRESSLY DISCLAIMS ALL IMPLIED WARRANTIES OF MERCHANTABILITY OR FITNESS FOR A PARTICULAR PURPOSE. THE PURCHASER AGREES THAT IN NO EVENT SHALL VP BE LIABLE FOR SPECIAL, INCIDENTAL OR CONSEQUENTIAL DAMAGES, INCLUDING DAMAGES TO THE ENGINE OR AIRCRAFT, LOST PROFITS, LOSS OF USE, OR OTHER ECONOMIC LOSS. EXCEPT AS EXPRESSLY PROVIDED HEREIN, VP DISCLAIMS ALL OTHER LIABILITY TO THE PURCHASER OR ANY OTHER PERSON IN CONNECTION WITH THE USE OR PERFORMANCE OF VP' PRODUCTS, INCLUDING BUT NOT LIMITED TO STRICT PRODUCTS LIABILITY IN TORT.**

## Change Log

Change date	Change
3-15-10	Initial public release
4-6-10	Added auto trim wiring section
4-22-10	Added alternator wire size note, diagram for third trim axis, wiring a switch in series.
10-12-10	Added MGL to PC interface cable to serial connections section. Changed the way in which the MGL EFIS is configured.

## 1 Introduction

### 1.1 Welcome to Vertical Power!

The VP-X is a new and innovative way to intelligently control the electrical devices on your aircraft using electronic circuit breakers (ECBs). It works with both 14 and 28 volt systems.

While the VP-X makes life a lot easier for the builder, it's not simply a plug-and-play solution. The builder must still run wires to electrically-powered components and this wiring takes some careful planning. Please take the time to read and understand this manual before proceeding.

This manual describes the installation steps and techniques necessary to install the VP-X. It is also intended to provide the information you need to know to capably wire your electrical system. Because many of the features are controlled using the setup menus rather than with hard-wired components, you can easily change things in the future.

This manual is constantly updated, so check the Vertical Power web site for updates during your build.

If you follow each of the five steps outlined in this manual, you will have a safe and full-featured electrical system.

### 1.2 Vertical Power Terms

Device	A user of electrical power. It may be a light, radio, GPS receiver, contactor, or EFIS, just to name a few. A device is wired to a power pin on the VP-X.
Pin	A pin refers to a physical pin on one of the VP-X connectors that provides power to a device. Special-purpose pins are provided for flaps, trim, starter, and EFIS. Most pins, however, are generic and can be configured to match the type of load it is powering. Each pin has a maximum current rating up to 15amps.
State	There are three states: on, off, or faulted. Faulted is equivalent of a tripped circuit breaker.
Connector	Two types of connectors are used throughout the system. D-sub connectors are smaller and provide signal and low power (less than 2 amps) connections. Vertical Power uses high quality, gold plated, machined-barrel connectors. High-quality, Molex gold-plated connectors are used to provide power (up to 15 amps) to high current devices.
Control Unit	The VP-X, or "red box."
AWG	American Wire Gauge – a standard that describes the size of the wire.

Circuit breaker	While the VP-X does not use conventional circuit breakers or fuses, the term is very common and herein is used to mean the maximum current a circuit will draw before faulting.
Fault	The VP-X protects each circuit from short circuits, over-current conditions, and current fault (open circuit) faults. When a fault occurs, the VP-X turns the faulted device off, and the EFIS displays an alarm message and an audio tone. You can then reset or clear the fault from the EFIS screen, similar to resetting a circuit breaker.
Backup circuit	A backup circuit allows you to power a device directly from the battery through an external switch (separate from the VP-X). When the external switch is turned on, fused power is provided directly from the battery to the device regardless of whether or not the battery contactor is closed or the VP-X is turned on. Wiring these circuits is optional.
B-lead	This is the large wire that goes from the alternator to the main electrical bus. It provides current from the alternator to the battery and electrical bus.
p-lead	This is the wire that goes from the mag switch to the magneto. There is a p-lead for each magneto.

### 1.3 Other Reference Documents

Vertical Power provides other documents that should be used in conjunction with this manual to help you thoroughly plan a safe and effective electrical system for the type of mission you fly. The following documents are available on the Documentation page of the Vertical Power web site ([www.VerticalPower.com](http://www.VerticalPower.com)), and should be reviewed in conjunction with planning your electrical system.

<u>Document</u>	<u>Description</u>
Load Planning Worksheet	This Excel spreadsheet guides you through planning and configuring the VP-X. It allows you to document and plan various parts of the required setup.
Contactor Wiring	Overview of the different types of contactors used in experimental aircraft, and step by step instructions how to wire them properly.
Device Amps	This document lists the electrical current draw of many popular radios, GPS moving maps, EFIS displays, lights, and other avionics. It is maintained by Vertical Power, but contributions come from builders.

Additional documentation may also be available on the web site.

## 2 Electrical System Basics

This manual and the accompanying documentation on the Vertical Power web site are intended to provide enough detail to understand overall concepts and safely wire your aircraft. Should you want more information, additional resources can be found in a variety of books and texts, a few of which are shown here:

- FAA Advisory Circular AC 43.13, *Acceptable Methods, Techniques, and Practices – Aircraft Inspection and Repair* available from [www.faa.gov](http://www.faa.gov)
- FAA Advisory Circular AC 23.1311, *Installation of Electronic Display in Part 23 Airplanes*, available from [www.faa.gov](http://www.faa.gov)
- EAA *Hints for Homebuilders* <http://www.eaa.org/video/homebuilders.html>

- Aeroelectric Connection book, available from [www.aeroelectric.com](http://www.aeroelectric.com)
- <http://www.sportair.com/articles/Electrical%20Systems%20Simplified.html>
- Movies: [http://www.heli-chair.com/videos\\_public/wiring\\_videos/2007\\_wiring/](http://www.heli-chair.com/videos_public/wiring_videos/2007_wiring/)

An aircraft electrical system can be divided into three parts:

1. “Backbone” components: aircraft battery, alternator, voltage regulator, contactors and associated wiring. Contactors are just high-capacity relays that are energized by low power signals but allow large amounts of power to pass through.
2. Busses, switches, and circuit protection (fuses and/or circuit breakers)
3. Users of power and the wiring to and from those users. Users may be lights, instruments, avionics, pumps, etc. The term *device* or *load* is used in this manual to generically describe all the users.

More on electrical system basics:

- The aircraft **battery** and **alternator** provide power to all electrically-dependent systems. Normally, the battery powers systems before and during starts and then the alternator takes over charging the battery and providing power to the electrical devices. A **battery contactor**, connects (or disconnects) the high-current wires between the battery and the main power distribution bus.
- Power typically runs from the battery/alternator to **electrical busses** behind the panel where power is split and sent to individual devices through **circuit protection devices** (fuses and circuit breakers) and switches. The VP-X assumes the role of busses, circuit protection, and a host of single-function modules. During construction, the VP-X greatly simplifies the task of wiring your aircraft.
- **Wire** sizes vary and the size of the wire to each device is determined by the current load (amps) of that device as well as the distance the current must travel. If a wire is too small for the load or distance, it will heat up and possibly fail. If the wire is too big, it will certainly carry the load but at the expense of added weight.
- To complete the electrical path, devices must have a ground. This means connecting a ground wire to the metal aircraft structure (aircraft ground) or running a ground wire from the device to a central location such as a firewall grounding point.

## 2.1 Alternator Operation

The alternator provides power to devices and also charges the aircraft battery. The **voltage regulator** continuously monitors the bus voltage and adjusts the output of the alternator. The regulator only works when it is powered from a bus through a wire called the **field wire**. Some alternators are internally regulated (the regulator is built in), and others have external regulators (a separate box located outside the alternator).

Today’s experimental aircraft are powered by either 14 volt or 28 volts systems. Often you may hear 12 volt or 24 volt systems. Why the difference? The reason is because the batteries are rated at either 12 or 24 volts. When the engine is running and the alternator is turned on, the alternator generates 14 volts or 28 volts, slightly higher than the battery voltage so it will keep the battery charged.

If you have a primary alternator and a secondary (backup) alternator only one alternator (field wire) should be powered on at a time. Therefore, we refer to one alternator as the primary and the other as the secondary. If both are on simultaneously, they do not equally “contribute” to powering the loads.

The one whose voltage regulator is set to the highest voltage will draw all the current (sometimes called current hogging), possibly overloading the alternator.

When planning your electrical system, assume the alternator provides 80% of its rated output (in amperes), and therefore your total continuous load (don't worry about trim or flaps or other transient loads) should not exceed 80% of rated alternator capacity.

## 2.2 Wire Sizes and Circuit Protection

A table below shows wires sizes versus loads for a typical homebuilt-size airplane. **The wire size can be larger than necessary but should not be smaller.**

Circuit breakers (and fuses) protect the wiring, not the device. If the breaker is too large, then the wire may overheat and fail. If too small, then the device may fault (breaker trips) because it draws too much current.

Most kit aircraft companies and avionics companies provide recommendations for sizing wires and breakers. You can use these recommendations. Or, you can borrow or purchase an ammeter (typically under \$50 at Radio Shack, etc.) measure the current draw of each electrical device and then determine the sizes yourself.

When you know the current draw for each device, use the chart below to size the power wires. For simplicity, the wiring harnesses available from Vertical Power use the four wire sizes in the table.

Up to (amps)	Use wire size (AWG)
5A	20
10A	18
15A	14
Data signal	22

## 2.3 Grounding

Many people think that the power, or positive, wire is the most important wire to provide electricity to a device. The electrical ground is just as important as electricity must flow the entire path from the power source to the device and back to the source. The ground wire must be the same wire gauge or a larger diameter (smaller gauge number) as the wire that provides power to the device.

A *ground loop* is when electricity can take two different paths, and each path has a different resistance. Ground loops are most noticeable in aircraft audio equipment, and can produce a variety of problems, most notably unwanted noise.

Grounding is as much of an art as it is a science. With that in mind, several options for grounding your system are provided below. Choose the one that best fits your needs. Keep in mind that more wiring means more weight (although likely negligible). Also, note that in all the examples below the avionics grounds are kept together.

- Option 1: Run a ground wire from each and every electrical device back to a common grounding point, typically a ground bus on the firewall.

- Option 2: Run ground wires from all the avionics to an intermediate grounding point, then run a larger wire from the local ground bus to the firewall ground. Run wires from all the other devices to the firewall ground.
- Option 3: Run the ground wires from the avionics to the firewall ground, and run the other ground wires to a local ground (a metal part of the airframe located near the device).

## 2.4 Switch Nomenclature

There are many types of switches available for use in aircraft, and this manual will show the basic types. The chart below shows the most common switch types. A parenthesis ( ) around a switch position indicates it is a momentary, spring-loaded position.

Switch Type	Abbreviation	Symbol	Mechanism
Single Pole, Single Throw	SPST		OFF-ON OFF-(ON)
			OFF-(ON)
Single Pole, Double Throw	SPDT		ON-NONE-ON ON-OFF-ON (ON)-OFF-(ON) ON-OFF-(ON)
Double Pole, Single Throw	DPST		OFF-ON OFF-(ON)
Double Pole, Double Throw	DPDT		ON-NONE-ON ON-OFF-ON (ON)-OFF-(ON) ON-OFF-(ON)

## 2.5 Alternator Current Sensing

When planning your aircraft electrical wiring you must consider whether to wire an ammeter (usually a shunt or hall effect sensor provided with the engine monitor) on the wire connecting the alternator(s) to the main bus. The ammeter will indicate the amount of current the alternator is providing.

Our recommendation is that an ammeter is not necessary with the VP-X because the functionality built into the VP-X precludes the need for an external device.

### 3 Vertical Power Overview

#### 3.1 Installation Overview

The installation of the VP-X is accomplished in five main steps, and the amount of work for each step is shown by the relative size of the boxes:

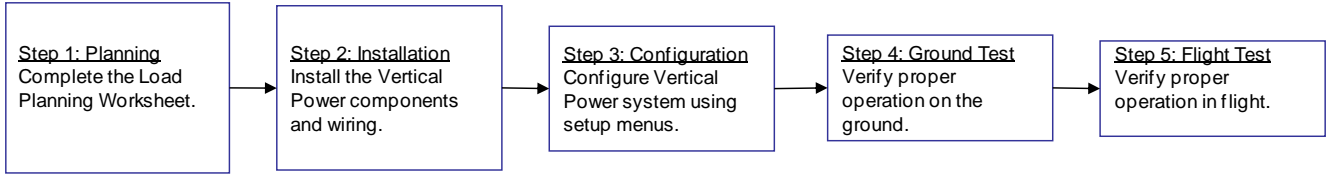

Following these steps will increase the likelihood of a trouble-free electrical system. Each step is described in detail later in this manual. You can optionally swap steps 2 and 3 and set everything up on the bench first.

**We recommend that you read through all five steps so that you better understand the system prior to beginning the planning step.**

Taking the time up front to carefully plan your electrical system will pay big dividends later on.

#### 3.2 System Overview

The VP-X provides circuit protection, circuit switching, trim and flap control, and a host of other functions. The electrical devices are controlled by conventional switches that are wired into the VP-X. The VP-X integrates with popular EFIS units, which display electrical system information. The EFIS is also used to configure the VP-X and to perform software updates and backups.

The VP-X system architecture is shown below:

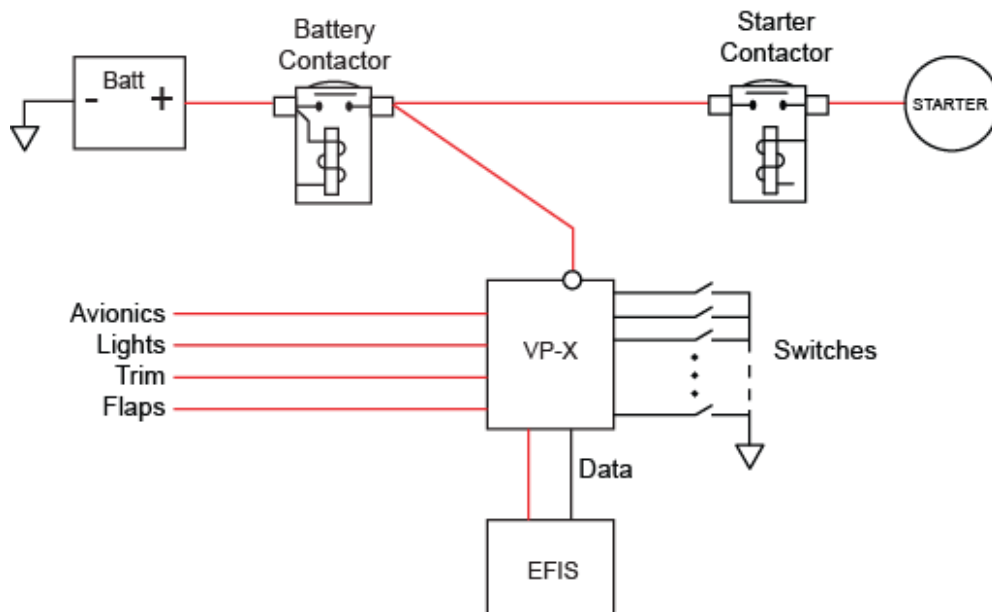

#### 3.3 Supported Bus Architecture

The VP-X supports a single bus architecture, with one or two alternators and one or two batteries.

## 4 Planning

It is a good idea to spend time on the planning stage whether you are installing a simple or a complex aircraft electrical system. This section discusses many items and considerations that should be incorporated into your planning. At the end of the section, you will be asked to complete the Load Planning Worksheet which documents the design of your electrical system.

### 4.1 EFIS

We recommend purchasing the EFIS with its backup battery option.

### 4.2 Wiring Harness

A wiring harness is available from Vertical Power to simplify the installation of electrical system. Appendix B at the end of this manual details the contents of the wiring harness kit.

### 4.3 Tools and Other Stuff

This is a generic list of items to assist with planning. Some items may vary depending on the requirements of your specific installation.

Things you will need	Things you won't need
<ul style="list-style-type: none"><li>● Crimper – insulated terminals 10 to 22 AWG</li><li>● Crimper – d-sub machined barrel male</li><li>● Crimper – terminals for 2 to 8 AWG wire</li><li>● Stripper(s) – for wire 14 to 26 AWG</li><li>● Starter contactor</li><li>● Battery contactor</li><li>● Heavy gauge wire for “main” power runs</li><li>● Heavy gauge wire terminals (non-insulated)</li><li>● Alternator(s) and voltage regulator(s)</li><li>● Wires for data interconnects on avionics</li><li>● EFIS – for VP-X status and setup</li><li>● Ray Allen Co. POS-12 flap position sensor (optional)</li><li>● Magneto/starter switch</li><li>● Switches</li></ul>	<ul style="list-style-type: none"><li>● Flap Positioning System</li><li>● Flap Controller</li><li>● Flap over-speed module</li><li>● Trim Controller</li><li>● Trim speed controller</li><li>● Wig-wag module</li><li>● Trim or flap position indicators</li><li>● Trim relays</li><li>● Trim voltage regulator</li><li>● Avionics relay</li><li>● E-bus diode</li><li>● Circuit breakers/fuses (except for backup circuits)</li><li>● Shunts/hall effect sensor</li><li>● Over-voltage module</li><li>● Low-voltage alarm</li></ul>

### 4.4 VP-X Connectors

The photos below show the different connectors used in the VP-X, the big, higher-amperage power connector on the left and the smaller, low-amperage d-sub connector on the right.



### Power Connector

### D-sub Connector

There are five connectors on VP-X. Four of these connectors, identified as J3 through J6, carry high-current loads. The fifth connector, J7, is a D-sub connector used for low-current purposes such as trim motor operation, position feedback, and switch inputs. The VP-X connectors are shown in the diagram below:

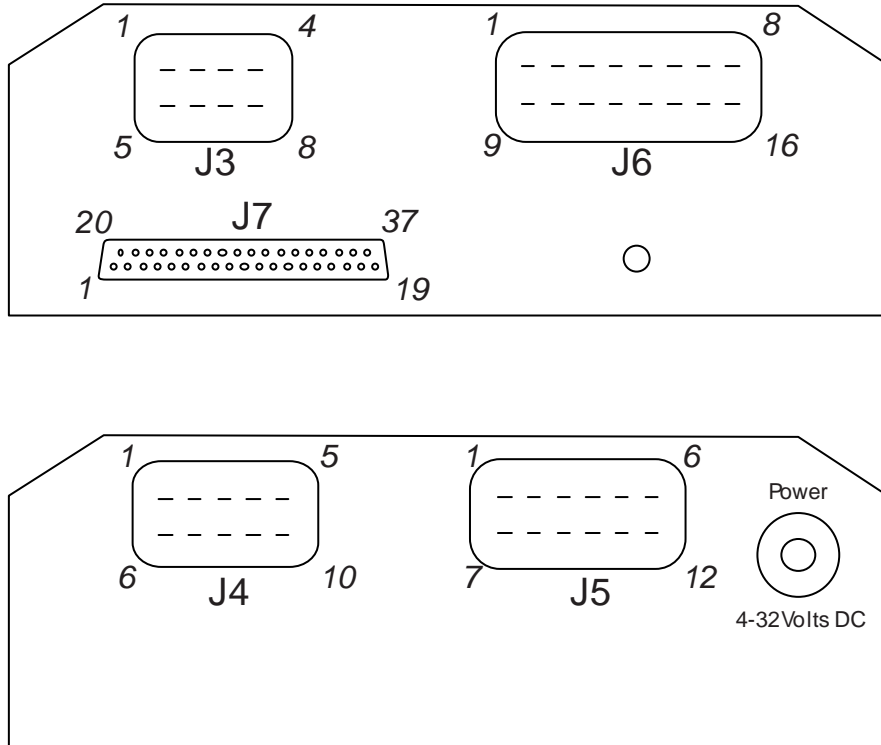

## 4.5 Installing and Removing Power Connector Terminals

The large (black) power connectors allow you to easily install and remove the wire/terminal assembly.

### 4.5a Installing terminals

Step 1: Insert a small screwdriver (max width= 1/8 inch, about 3.0 mm) into either pry point

Step 2: Using the housing as a pivot point gently pry out on the white insert, until it reaches pre-lock position (5.0 mm travel)

Insert screwdriver



Gently pop up white section



Before



After



**The white insert should never be removed!  
If it is removed, discard the entire connector. Do not attempt to re-assemble.**

Step 3: With the white insert still in the 'out' position, align the terminal to rear of connector. Align the orientation feature as shown and insert through appropriate opening. If resistance is encountered, retract the terminal and adjust the angle of insertion. Continue inserting the terminal until it stops with an audible click. Give the wire a slight tug to make sure it is seated properly. It should not come back out.



**Orientation feature aligned with index**

**90° mis-orientation**

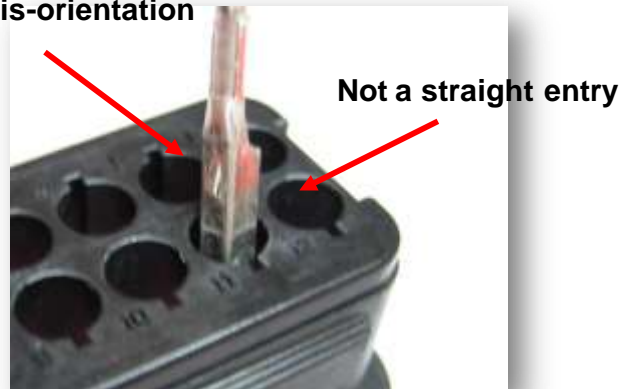

### Troubleshooting:

The terminal should insert smoothly into the connector housing. If it does not, the following are the most likely causes:

- The terminal is rotating while you are inserting it. The terminal must remain aligned until it is fully inserted.
- The tangs on the insulation crimp may not be fully closed. Gently squeeze the tangs closed around the insulation with a pair of pliers.
- The white insert may have closed. Open the insert.

Step 4: With the terminals fully installed, the white insert can be seated into its final lock position by applying an even force to both ends until it comes to a stop, with an audible click. The white insert should move a distance of 5.0 mm (about ¼”).

### 4.5b Removing terminals

Steps 1 & 2: Follow these steps as shown above to raise the white part of the connector.

Step 3: Using the pin removal tool, insert the tip into the terminal service hole adjacent to the terminal to be serviced.

Step 4: Push down gently to release locking finger. You will hear a gently click. **Do not apply any lateral force, as this may damage the connector or the terminal!**

Step 5: With the white insert still in the ‘out’ position, gently pull on the wire to release the terminal. If the terminal resists, the service tool may not be fully engaged. Remove the tool and re-try. Push the service tool further into the service opening to ensure that it has fully disengaged the locking finger.

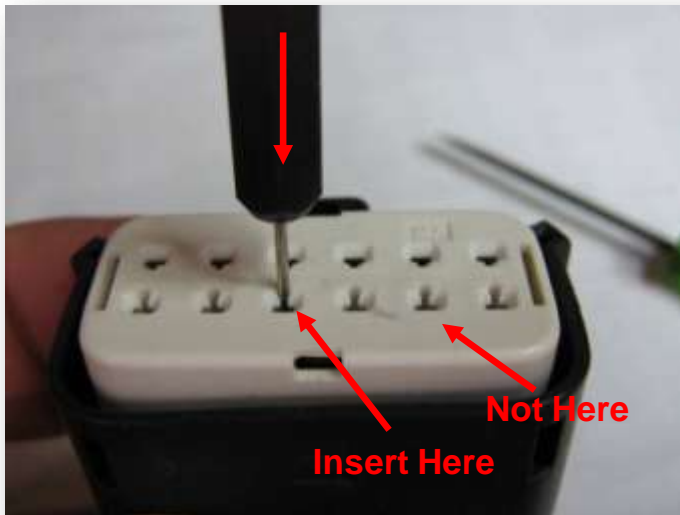

**Do not insert the tool into the terminal opening!**

**Do not use excessive force, excessive force can damage the connector!**

Step 6: The white insert can be seated into its final lock position by applying an even force to both ends until it comes to a stop, with an audible click. The white insert should move a distance of 5.0 mm (about ¼”).

## 4.6 Alternator and Voltage Regulator Considerations

Choosing the correct alternator and voltage regulator is an important part of planning your electrical system. The VP-X supports internally and externally regulated alternators, as well as the B&C SD-8 permanent magnet alternator. Vertical Power does not take a position regarding which type or brand of alternator is best.

The VP-X does NOT replace the voltage regulator. Externally-regulated alternators require a voltage regulator.

The typical automotive-style voltage regulator does simply that – regulates the voltage to the field wires on the alternator. Varying the field voltage affects the output capacity of the alternator. Higher voltage means a stronger field to generate current which means more output. An internally regulated alternator provides the same function, but the regulator is housed in the alternator itself.

Certain internally regulated alternators provided by Plane Power, Ltd. ([www.plane-power.com](http://www.plane-power.com)) have built in over-voltage protection. All alternators built by Plane Power are compatible with the Vertical Power system.

Externally-regulated alternators have the regulator in a separate box outside the alternator. Most voltage regulators provide only the voltage regulation function, and some allow you to adjust the voltage level. The B&C LR-3C ([www.bandc.biz](http://www.bandc.biz)) external voltage regulator provides three functions: 1) voltage regulation, 2) under-voltage alerting, and 3) overvoltage protection. It is generally regarded as a high-quality product that has been through years of field experience. Note: B&C does not recommend the LR-3C be connected to PTCs for circuit protection. The VP-X does not use PTCs for the power circuits and is compatible with B&C voltage regulators.

There is a long-standing and unresolved debate in the experimental community about the benefits of internally versus externally regulated alternators. The table below shows some of the pros and cons of each type:

	Pros	Cons
Internally regulated	<ul style="list-style-type: none"><li>• Simple to wire</li><li>• No external boxes</li></ul>	<ul style="list-style-type: none"><li>• Certain failure modes will cause over-voltage condition that cannot be stopped by removing power from the field wire*.</li></ul>
Externally regulated	<ul style="list-style-type: none"><li>• Separation of VR from alternator, and each can be serviced separately.</li><li>• Removal of power from regulator shuts down alternator.</li></ul>	<ul style="list-style-type: none"><li>• Extra box to install and wire</li><li>• Extra cost and weight</li></ul>

\*Note: According to Plane Power, their internally regulated alternators are designed to eliminate this failure mode.

Some common backup alternators are the accessory-drive mounted SD-20 alternator and the SD-8 PM alternator, both available from B&C Specialty Products. The one you choose is driven in large part by the size of the loads you need the backup alternator to carry.

#### **4.6a Over-voltage Planning**

An over-voltage condition is initiated by a failure in either the voltage regulator or the alternator which causes the voltage to rise above a safe level for the avionics and other electrical equipment. Typically the over-voltage level is set at 16.0 volts for a 14v system and 32.0 volts in a 28v system.

Over-voltage protection is provided by the VP-X, and therefore an external device is not needed for this function. Over-voltage protection is provided by removing power from the Field wire when the bus voltage exceeds a pre-set limit for a pre-set period of time. If your system comes with an overvoltage protection circuit, the Vertical Power system is compatible with “crowbar” type circuits. These simply short the alternator field wire to ground, causing the field circuit breaker to pop.

#### **4.6b Low-voltage Planning**

During flight, the normal bus voltage should be around 14.2 volts. A low voltage condition is most likely due to one of the two following circumstances:

1. The alternator has failed causing the bus voltage to drop from 14.2v to 12.4 volts or less (double for a 28v system).
2. The electrical loads on the aircraft exceed the capacity of the alternator, which is unable to keep the battery fully charged. The bus voltage will slowly decline until the low voltage alarm is triggered.

The low voltage alarm may be provided through the EFIS.

#### **4.7 Landing Light Wig-Wag (Pulsing) Considerations**

Various circuits can be configured to wig wag external lights. In order to flash two different lights, they must each be wired to a separate pin on the VP-X. Lights that are wired together to a single pin cannot be flashed separately (although they can be flashed together). Wire each light that you want to flash independently to separate pin.

In the EFIS setup menu, you specify which power pins you want to wig wag. It then alternates power on those pins. For example, if you configure two lights, a taxi light and a landing light, then those two pins will wig-wag or pulse. Pulsing begins automatically above a specified airspeed so the lights are always steady on the ground and pulsing when in the air. You can specify the warm up time (5 secs to 60 secs), and the light is steady on for the specified time period before pulsing.

#### **4.8 Electronic Ignition Considerations**

The VP-X can be used with various electronic ignitions (EI) as long as the appropriate safety considerations are taken into account. Most EIs, such as Lightspeed or E-mags, require external electrical power to operate. Others, such as P-mags or Lasar, have internal backups and can operate with or without external power. P-mags require external power for starting and idle.

**Make sure that at least one ignition source is wired directly to the battery as per the ignition manufacturer’s instructions if you are running dual EIs that require external power!**

If at least one magneto or p-mag is installed, you can provide power to the other ignition via the VP-X. Consider using some form of Backup Circuit to provide power in case of multiple failures (failure of the magneto and failure of the VP-X at the same time-unlikely but possible).

Some examples are shown below, and are meant to be guidelines only. **The builder is responsible for determining the appropriate level of redundancy for his or her aircraft:**

- Dual Lightspeed or e-mag ignitions: wire one directly to the battery (per manufacturer's instructions) and one to the VP-X. Or, wire both to the batteries per the ignition manufacturer's diagram.
- One Lightspeed/e-mag and one magneto: wire the Lightspeed/e-mag to the VP-X.
- Dual p-mags: wire both to the VP-X.
- One e-mag and one p-mag: wire both to the VP-X on individual power pins.
- Dual magnetos: neither is wired to the VP-X, as they don't require external power.
- Lasar: Wire the Lasar power to the VP-X.

#### **4.9 Load Planning Worksheet**

The Load Planning Worksheet is the first step in planning your electrical system. You then use this completed sheet to wire the aircraft and to configure the VP-X using the EFIS setup menus. Completing the Load Planning Worksheet will guide you through the planning process and hopefully answer many questions you may have along the way.

You will find that the Load Planning Worksheet has many uses. It can be used to:

- plan pin connections prior to entering the data in the EFIS setup menu
- analyze overall electrical system loads
- aid while wiring your aircraft
- document the wiring in your aircraft for future reference

We recommend reading the Installation section of this manual prior to completing the worksheet.

The worksheet is divided into several Excel worksheet tabs. Fill out each tab.

##### **4.9a System tab**

This tab in the worksheet documents your overall electrical system configuration.

##### **4.9b VP-X tab**

J3 through J6 are power connectors, and J7 is a d-sub connector. "J" is a term used to name a connector.

Vertical Power Load Planning Worksheet									
VP-X									
		Max Amps	Pin Name	Circuit Breaker	Actual Amps	Switch	Curmt Fault	AWG	Notes
<b>J3 Power</b>									
6	1	10	Flap					18	Connect both wires to flap motor
7	2	10	Flap					18	Connect both wires to flap motor
8	3		Unused						
9	4	10	Starter Output					18	Wire to starter switch then solenoid
10	5	5	Alternator Field (Main Alt)		2.0			18	
11	6	5	EFIS power					20	Wire to EFIS that is connected to CU
12	7	5	5A output 1					20	
13	8		Unused						
<b>J4 Power</b>									
16	1		Unused						
17	2		Unused						
18	3	10	10A output 1					18	
19	4	10	10A output 2					18	
20	5	10	10A output 3					18	
21	6		To GND block	Ground				18	Wire to main ground block
22	7	3	3A output 1 (regulated +14v)					20	No audio or alternator here
23	8		3A output 2					20	

Items in magenta are not configurable, and you must use those pins for the specified function.

Each column is explained below:

- **Max Amps:** The maximum current load that a pin is capable of handling. A load drawing more than this amount of current will fault (i.e., turn off) the load.
- **Pin Name:** You can give each pin a name that shows on the EFIS display.
- **Circuit Breaker:** The maximum current allowed for that pin. You can enter any value between 1 and the limit of that pin in increments of 1A. This value is equivalent to a circuit breaker or fuse. If a load draws more than the Circuit Breaker value, that circuit will fault. If too large of a breaker value is used, then the wire may overheat or fail. If too small a value is used, then the device may fault the circuit because it draws too much current.
- **Actual Amps:** The actual current drawn by a device. It is recommended you measure the ACTUAL current draw of each device prior to installation in the aircraft using an ammeter (commonly available from a friend at no cost or from Radio Shack, Sears, and electronic supply stores for a reasonable one). The total actual current draw should not exceed 60 Amps.
- **Switch:** Enter the number of the switch input (switch input 1 through 10) you want to control this pin, or set to 'always on' or 'always off'. Each switch input is labeled 1 through 10. You can assign multiple devices to a single switch, and conversely, a switch can control multiple devices. If you set the circuit to 'always on', it will be on anytime the VP-X is powered (i.e. the master switch is on). Multiple pins can be assigned to a single switch. Switch inputs are J7 pins 11, 12, 21, 27, 30, 33, 34, 35, 36, 37. You don't have to use all of the switch inputs.
- **Current Fault:** The pin can be configured to detect a "current fault" or open circuit. When a circuit with this feature enabled is turned on and does not draw any current for 3 seconds, the circuit is faulted. You can use this to detect burned out lights, faulty boost pump, failed avionics fan, or inop heated pitot tube for example. The minimum detectable current is about 100ma, so this should be used on devices like lights, strobes and loads that draw at least 100ma of current.
- **AWG:** The size of the wire based on the industry standard American Wire Gauge. This is the minimum recommended size wire for this circuit. Do not use a smaller gauge (bigger gauge number) wire.

Fill in J7 with the appropriate data, switch, and trim/position sensor connections. Note that the flap position sensor is wired to J7 and the flap motor power is wired to J3.

#### 4.9c What if I run out of power pins?

There are several options if you have more electrical devices than power pins on the VP-X. Evaluate each of the following and choose the one that makes the most sense for you:

1. Send your LPW to [info@verticalpower.com](mailto:info@verticalpower.com) and we can help you with it.
2. Combine several devices together on a power pin. Typically these are low-current devices that are all switched on and off together. Since the circuit protection is designed to protect the wire, you can group items as long as the CB value does not exceed the specs for the smallest wire. For example, an XM receiver and CO detector could be combined on a circuit and set to 2A fuse. Downside is if one device faults, then all devices lose power.
3. Create an auxiliary bus by running an 18 gauge wire from one of the 10A power pins (set CB to 10A) to a fuse block with 6 or so fuse holders. From each fused tab, run a wire to the device. Do not install fuses rated at more than 3A, and ensure the total load does not exceed about 8A. Often devices that need a 1 to 3 amp fuse draw less than half an amp, so you can easily put 6 or 8 devices on a fuse block. When an individual fuse blows, the others are unaffected. All devices will be turned on and off together.
4. If you're wiring backup circuits, you may already have a fuse block designed to power the backup circuits. Run devices off this fuse block, through external switches.

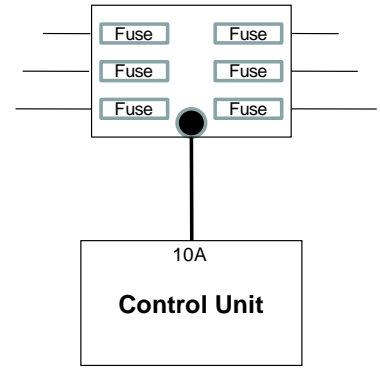

#### 4.9d What if I run out of switch inputs?

If you need more than 10 switches (plus the master, trim, and flap switches), you can wire the switch in series between the VP-X and the device. We recommend using circuits with low-current loads like cabin lights, panel lights, or other similar devices. Doing so allows you to use the same style of switch for all devices (you don't have to install a special high-current switch). Wire as shown in the diagram below:

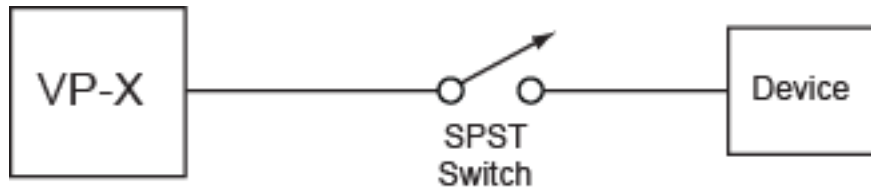

Unlike the other switches, this switch must be rated to carry the current load of the device.

## 5 Installation

This section walks you through wiring the power wires for the aircraft. The VP-X is the heart of the wiring system in your aircraft, and careful planning up front will make the installation process fairly straightforward. The VP-X has four connectors for high-current power and one connector for low-current power and signals.

### 5.1 Pre-Installation Tasks

**Warning:** Disconnect battery power before installation.

Before you begin the actual wiring, be sure to review and understand the wiring diagram. You must wire your aircraft to match the wiring diagram. Any deviations may cause unsafe or unknown results. Please contact Vertical Power tech support if you have ANY questions.

Prior to installation and wiring, the following should be considered:

- The battery(ies) in the aircraft should NOT be connected until the wiring is installed and each circuit is individually tested. Do not run wires while the battery is connected.  
**Tip:** Disconnect the battery ground cable first, then the positive cable. When re-connecting, connect the positive cable first then the ground cable. Doing so ensures you won't spark the positive connection to the airframe.
- Consider bench testing the system and the devices prior to actually installing it in the aircraft. This allows you to become familiar with the system in a comfortable environment.
- Build the wiring harnesses to match your Load Planning Worksheet prior to installing in the aircraft. If the wiring harnesses are complete prior to installation in the airplane, you can "lay them in" the airframe.
- The easiest method is to run the wires from the VP-X to their destinations. For example, simply run the wire from the VP-X to the landing light area, along with a ground wire, and that circuit is basically complete.
- Use good quality, gold-plated connectors for intermediate connections. For example, you may want to use a connector for all the instrument panel wires that go to the rest of the airplane. Consider using a connector for all the control stick wires, so that you can remove it later if needed.
- Plan the physical wire routing in your aircraft prior to installing the harnesses. Drill any necessary bulkhead holes and protect sharp edges with snap bushings, grommets or other suitable fastener.
- Leave room for service loops (extra lengths of wire), so that you can easily remove and install components later.

**DO NOT GRIND, FILE, DEBURR, OR DRILL METAL OR FIBERGLASS AIRFRAME COMPONENTS WITH THE UNITS INSTALLED, AS SHAVINGS MAY GET INSIDE THE UNITS AND CAUSE INTERNAL SHORT CIRCUITS.**

Use the VP-X empty shells during construction.

These shells are available for a small, fully-refundable deposit from Vertical Power.

## 5.2 VP-X Installation

The VP-X is typically located behind the instrument panel, but may be mounted almost anywhere in the interior of the aircraft where it is protected from direct exposure to the elements.

Locate the VP-X taking the following into account:

- The VP-X should be located inside the cabin, away from occupants and baggage.
- The VP-X is not water-resistant and should be located away from possible water exposure. If you have a tip-up canopy or believe it may occasionally be exposed to water, use RTV silicone sealant to fill the small holes where the case meets the end caps. Do not put sealant on the connectors.
- The VP-X should NOT be mounted to the firewall where it is exposed to direct heat and vibration.

- Locate where you can relatively easily access the VP-X and the power connectors for troubleshooting during installation and in the future.
- Air should be allowed to circulate around the VP-X. A fan is not required.
- Do not locate near sensitive equipment such as a compass or AHRS. While no known interference exists, you should test and verify that an operational VP-X does not affect other equipment prior to finalizing the equipment locations.
- Do not mount where occupants can easily touch, kick, bump, or otherwise disturb the VP-X.
- The wiring harnesses for the VP-X should be secured at a point near the VP-X.

Recommended VP-X mounting locations:

**RV-7, 9, 10:** horizontally under the intermediate bulkhead (located between the firewall and instrument panel) using fabricated angle aluminum brackets. The VP-X is positioned roughly above the rudder pedal assembly, mounted to the brackets/intermediate bulkhead. For easy access, the VP-X can be mounted hanging downward from the brackets.

**RV-8:** in the right foot well, behind the panel on the intermediate bulkhead, or on braces above the rudder pedals. Be mindful of water coming in through the baggage door.

**Glastar:** Behind the panel.

**Lancair Legacy:** on the avionics tray in front of the instrument panel, along the tunnel behind the seats, or in the aft section of the fuselage.

**Lancair ES, IV-P:** on the avionics tray in front of the instrument panel, forward of the door along the fuselage, or in the aft section of the fuselage (within the pressure vessel).

*Note on mounting the VP-X in the rear of the aircraft*

You can mount the VP-X in the aft section of the aircraft, but be aware of the wire runs required for the switches. This may be attractive when space behind the panel is crowded or if the batteries are in the back of the fuselage. However, the standard wiring harnesses provided by Vertical Power assume the VP-X is mounted up front near the instrument panel. You will need to modify the standard harness to accommodate the longer wire runs to the avionics and other equipment mounted in the front of the aircraft.

The VP-X is designed with three mounting holes/slots on each side, and should be secured with a minimum of two AN3 (10-32) or 8-32 bolts, one on either side of the case.

- Mount the VP-X so that it is securely attached to the mounting surface.
- If mounting in a composite aircraft, or on non-conductive surface, run a wire from the VP-X chassis to the main ground block. Use a ring terminal around the mounting bolts or one of the four Philips screws at the outside edge of each faceplate. The red anodization acts as an insulator, so use a toothed lock washer or gently scratch off the anodization so the ring terminal is electrically conductive with the case.

### 5.3 Wiring Harness Construction

Review the *Connector Service Manual* and *Contactors Installation Guide* prior to proceeding with this section.

The connectors are labeled with the pin numbers next to each hole on the black side of the connector.

The wires in the wiring harness kit have a terminal pre-crimped to one end of each wire intended for use in the power connectors. The terminals for the power connectors require a special crimp tool which is available for rent or purchase from Vertical Power. The d-sub wires come in longer lengths

that you can trim to the desired length and crimp on the pins with standard d-sub crimping tool. Do not use generic crimp tools as doing so may result in a poor mechanical connection.

Construct the wiring harness following these steps:

- Using the Load Planning Worksheet as a guide, and following the instructions in an earlier section about installing and removing wires, insert each wire into the correct location in each of the connectors.
- Double check that the correct wires are in the correct pins in the correct connector**, based on your setup in the *Load Planning Worksheet*. Remove any unused wires from the connector. Additional wires can be easily added later.
- Begin by plugging the connectors into the VP-X and let the wires hang freely. Group the wires into bundles that go to a specific location in the aircraft. For example, group all the wires that go out to the left wing together.
- Run the bundles to their respective general locations. Keep in mind that ground return wires may also need to share space in the bundle as well.
- Secure the wires near the VP-X to minimize stress on the wires at the connector.

#### 5.4 Backbone Wiring

Below is a diagram showing the major parts of the electrical system. Each section is described in detail in instructions below. Refer to the wiring instructions from the airframe manufacturer for wire sizing.

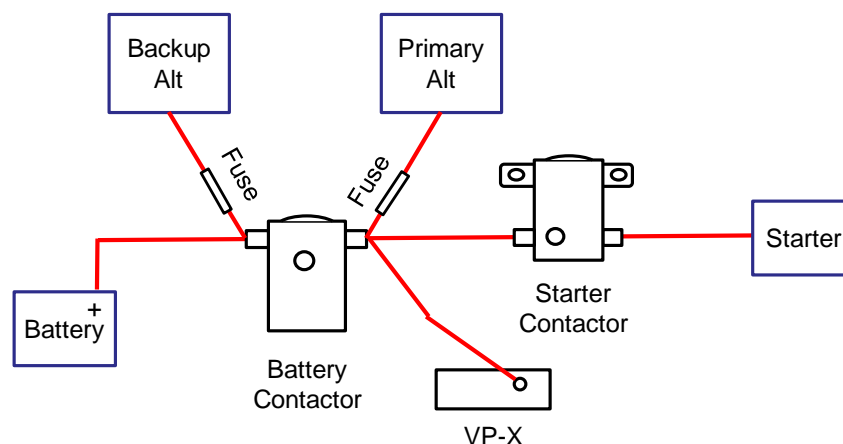

#### 5.5 Master Contactor Wiring

**CAUTION: DO NOT CONNECT THE BATTERY UNTIL THE SYSTEM IS WIRED AND TESTED.**

The master contactor (aka master relay, master solenoid) is controlled by applying ground to the small post on the contactor. Some contactors come with two small posts, some come with one. Be sure that you install a “continuous duty” contactor. The contactor typically draws less than 1 amp when energized.

- Connect the diode (included with the system) to the battery contactor as shown below. The diode will extend the life of the contactor, and may serve to minimize damage to sensitive

avionics.

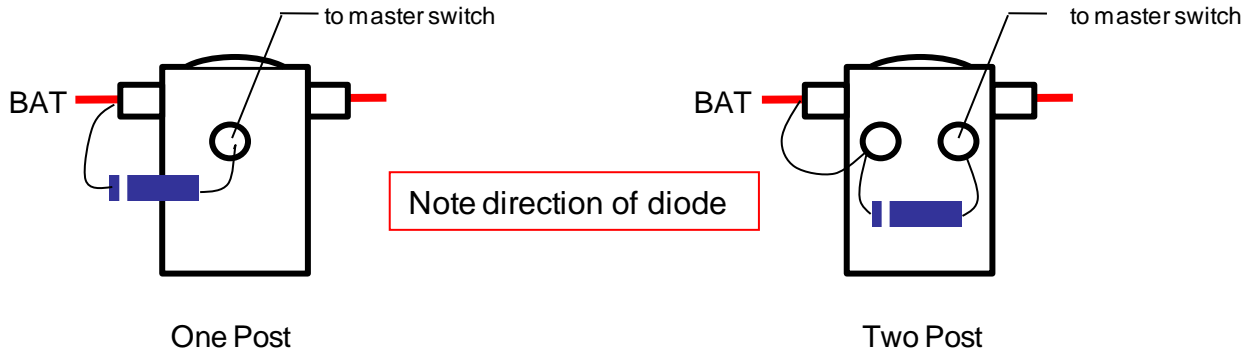

- Install a 20 AWG wire from the small post of the battery contactor to the master switch.
- Connect the other side of the master switch to ground.

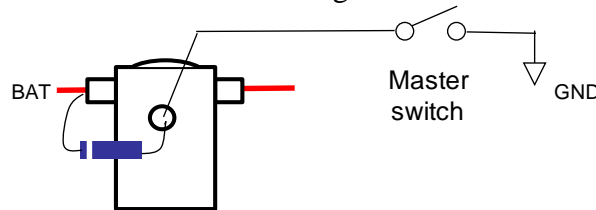

- Connect the main power wire from the battery contactor to the power lug on the VP-X using a 1/4" (0.250") ring terminal. Cover with a molded plastic cover. You must use either a 6 or 8 AWG wire for this cable. Use 6 AWG if the run is over 4 ft or if the max planned load is >45 amps. Use 8 AWG for all other situations. Torque to 36 in-lb (3 ft-lbs). **Do not over-torque the nut** – all you need is a snug fit. The power lug is a soft copper alloy and will break if over-torqued.

Connect the cable to either the battery contactor post or the starter contactor post – they are electrically identical, but one may be more convenient than the other depending on your layout.

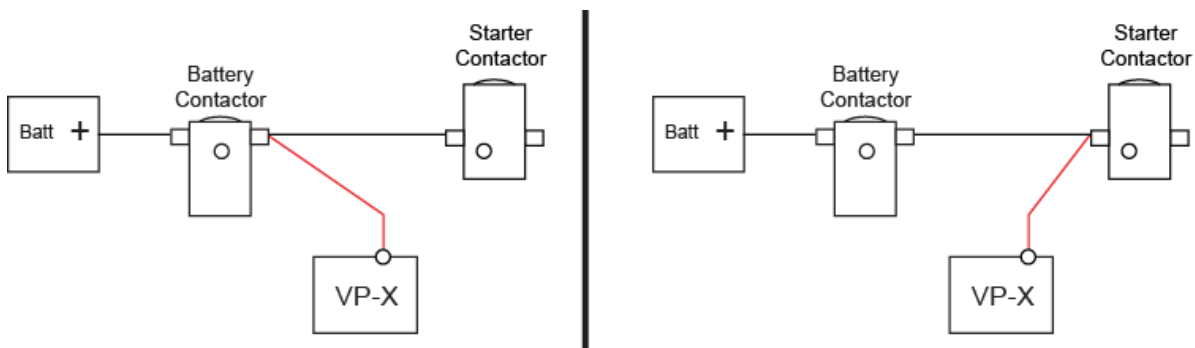

### 5.6 Starter Contactor Wiring

Function	VP-X Pin	I/O
Starter contactor coil power	J3-4	O

**CAUTION: DO NOT CONNECT THE BATTERY TO THE BUS UNTIL THE SYSTEM IS WIRED AND TESTED.**

The starter contactor is controlled from a switch which is powered from J3 pin 4. J3-4 is ALWAYS ON (unless the engine is running) so a switch MUST be installed in between the VP-X and the starter contactor. A diode for the starter contactor coil is built-into the VP-X.

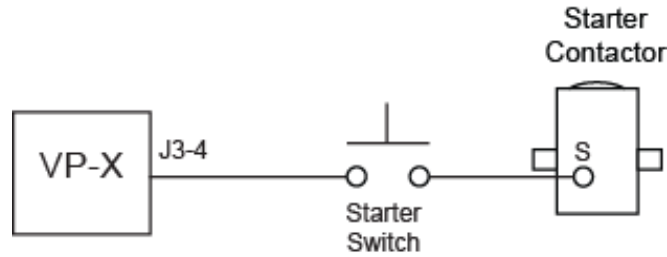

**CAUTION:**  
DISCONNECT THE CABLE BETWEEN THE STARTER CONTACTOR AND STARTER UNTIL THE ELECTRICAL SYSTEM IS COMPLETELY TESTED

- Install an 18 AWG wire from J3-4 to the starter switch.
- Install an 18 AWG wire from the starter switch to the “S” terminal on the starter contactor, shown below.

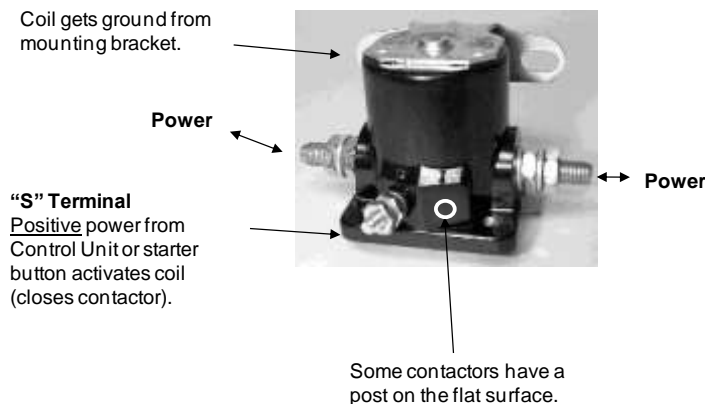

The starter contactor typically draws about 2 to 4 amps (depending on model) at 14 volts. The VP-X can operate down to 4 volts, so it will not reboot during normal engine starting. The VP-X does not boost voltage to any of the devices it powers.

### 5.7 Starter Annunciator Wiring

Function	VP-X Pin	I/O
Starter annunciator input	J5-12	I

This pin measures voltage on the starter (or switched) side of the starter contactor and reports it to the EFIS for display. If enabled on the EFIS, an annunciator appears whenever the starter contactor is engaged. A resistor should be placed in-line near the contactor to provide circuit protection for the wire.

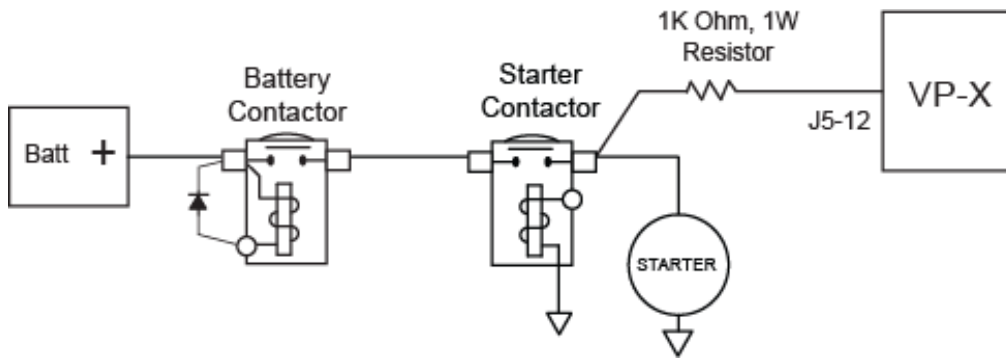

- Install a 20 AWG wire from J5-12 to the switched side of the starter contactor. Install a 1K Ohm, 1 watt resistor in-line near the starter contactor.

### 5.8 Other Contactor Wiring

If other contactors (for hydraulic pumps, air conditioning, etc.) are installed in the aircraft, they must have diodes installed across the coil as shown above.

- Install diodes on the other contactors.

### 5.9 Alternator Wiring

The VP-X supports a single or dual alternator system. There are several types of alternators that are common among homebuilders, and each is shown in detail below. If your specific alternator or voltage regulator is not listed below, use the directions that came with it – it should be similar to the wiring described here.

The VP-X does NOT replace the voltage regulator. Externally-regulated alternators require a voltage regulator.

The wiring diagrams below show the use of 20 AWG wire for the alternator field circuit. The Load Planning Worksheet and VP-X wiring harness use 18 AWG wire. The larger wire provides a bit more resilience in the harsh environment of the engine compartment. Electrically, though, either size wire is appropriate.

#### 5.9a Primary Alternator (B&C External Regulator)

The B&C LR-3C voltage regulator can be used with several of the B&C alternators and other externally regulated alternators. Do not use the SB1B regulator. The LR-3C requires a power for the field as well as a power for the voltage sense wire, which senses the bus voltage in order to correctly regulate it. This diagram shows the alternator wiring:

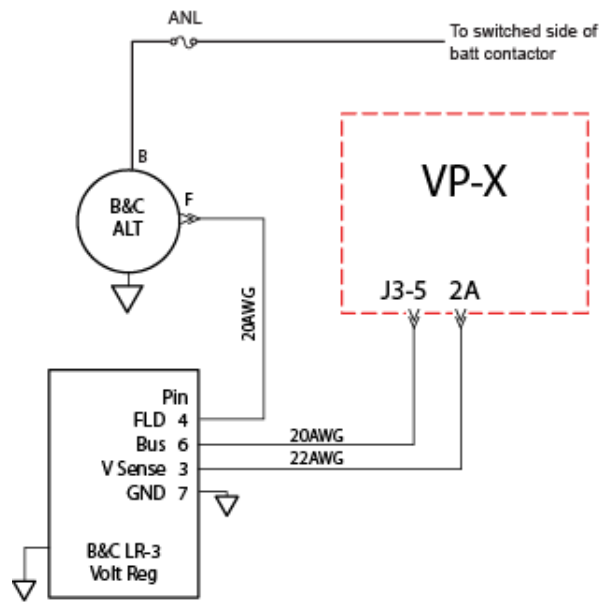

- Run a wire from any 2A or 5A circuit (DO NOT use the 3A circuit on J4-7) to pin 3 on the LR-3C.
- Set the circuit breaker value to 2A later when configured.
- Run a wire from the Primary Alt circuit (J3-5) to pin 6 on the LR-3C.
- Set the circuit breaker value to 5A later when configured.
- Run a wire from pin 4 on the LR-3C to the field input on the alternator.
- Ground the LR-3C as per B&C installation manual.
- Run the B-lead wire from the alternator to an ANL fuse on the firewall, then to the switched side of the battery contactor. The switched side is the large post on the opposite side of the contactor from the large post connected to the battery. The b-lead is typically a 6 or 8 AWG wire.

### 5.9b Primary Alternator (Plane Power)

The Plane Power alternator requires a single wire for the field. It has a built-in voltage regulator. This diagram shows the alternator wiring:

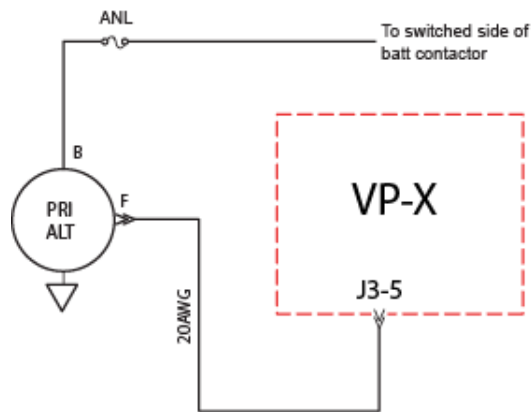

- Run a 20 AWG wire from the Primary Alt circuit (J3-5) to the field input on the alternator.
- Set the circuit breaker value to 5A later when configured.

- Run the B-lead wire from the alternator to an ANL fuse on the firewall, then to the switched side of the battery contactor. The switched side is the large post on the opposite side of the contactor from the large post connected to the battery. The b-lead is typically a 6 or 8 AWG wire.

### 5.9c Backup Alternator (B&C 20 Amp)

The B&C SD-20 20 amp backup alternator uses the LR-3C voltage regulator for 14 volt systems. If using the SD-20 on a 28 volt system, use the LS-1A voltage regulator from B&C. Do not use the SB1B regulator. The LR-3C requires a power for the field as well as a power for the voltage sense wire, which sense the bus voltage in order to correctly regulate it. *Note that you can connect the B-lead to either side of the battery contactor.* This diagram shows the alternator wiring:

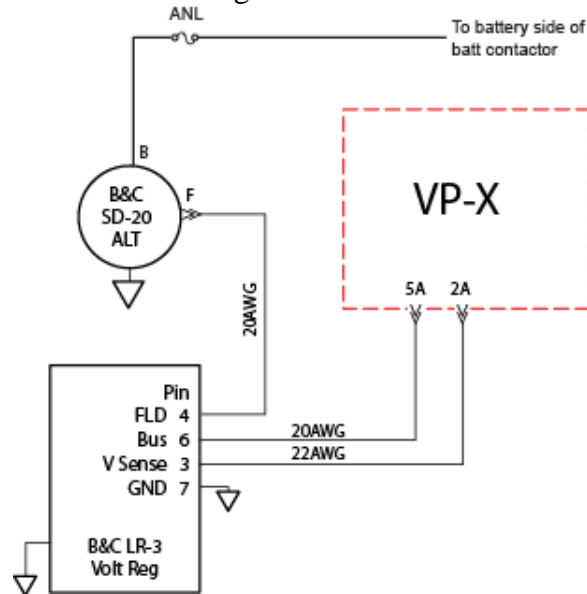

- Run a wire from any 2A or 5A circuit (DO NOT use the 3A circuit on J4-7) to pin 3 on the LR-3C. (See LS-1A instructions for pin outs on that regulator)
- Set the circuit breaker value to 2A later when configured.
- Run a wire from a 5A circuit to pin 6 on the LR-3C.
- Set the circuit breaker value to 5A later when configured.
- Run a wire from pin 4 on the LR-3C to the field input on the alternator.
- Ground the LR-3C as per B&C installation manual.
- Run the 12 AWG B-lead wire from the alternator to an ANL fuse on the firewall, then to the battery side of the battery contactor. NOTE: locate the fuse near the battery.

### 5.9d Backup Alternator (B&C 8 Amp)

The B&C SD-8 8 amp alternator requires a single wire to control the relay which isolates or connects the SD-8 to the bus. It uses the PMR-1 to regulate the voltage, which includes a regulator, capacitor, and battery. The Overvoltage (OV) crowbar module is not needed, as this function is included in the VP-X. The VP-X does not control the regulator directly, rather it open and closes a relay which allows the SD-8 output to flow to the bus. *Note that you can connect the B-lead to either side of the battery contactor.* This diagram shows the alternator wiring:

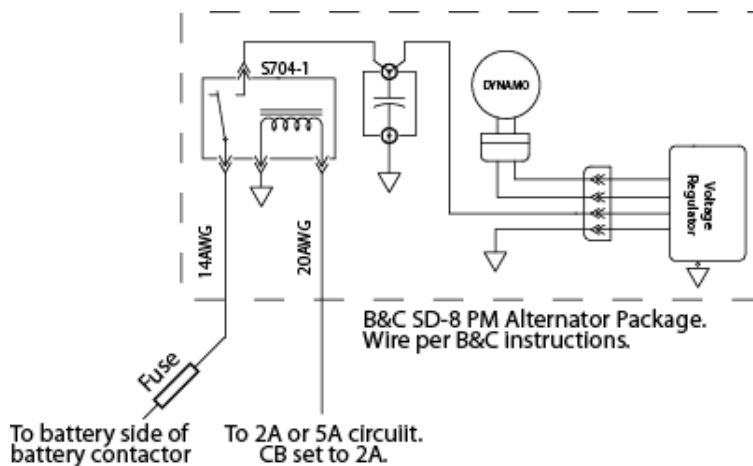

- Run a wire from a 2A or 5A circuit to the coil terminal on the relay that came with the PMR-1.
- Set the circuit breaker value to 2A later when configured.
- Connect the other side of the coil terminal on the relay to ground.
- Run a 14 AWG wire from the common terminal on the relay through a 10A fuse then to the battery side of the battery contactor. NOTE: locate the fuse near the battery.

### 5.10 Primary EFIS Wiring – Power and Data Connections

The “primary” EFIS is unique because it is the EFIS that displays the faults and status from the VP-X. This EFIS power must be wired to J3-6.

- Install a 20 AWG wire from J3-6 to the EFIS primary power input.
- If desired, install a backup circuit for the secondary power input on the EFIS. See “Backup Circuits” section later in this document.
- Connect the three data wires on the VP-X J7-1, J7-2, J7-20 to a serial data port on the EFIS. Typically serial data transmit and receive lines are grouped together on the EFIS. The transmit line (J7-1) on the VP-X goes to the receive line on the EFIS. Conversely, the receive line (J7-20) on the VP-X is wired to the transmit line on the EFIS. The VP-X communicates at 57600 bits per second.
  - AFS EFIS. Wire to the EFIS (if you have more than one) on which you want to see and control the electrical system. Use an serial port pair on the EFIS, including the associated serial ground line.
  - GRT EFIS. Wire to the EFIS (if you have more than one) on which you want to see and control the electrical system. Use a serial port pair on the EFIS, including the associated serial ground line.
  - MGL EFIS. The VP-X, when used with the MGL, is configured directly from a PC and therefore the serial port must be shared between the EFIS and the PC connector. Please see Appendix D for directions on making the PC interface harness. Use any RS232 port on the EFIS except for the dedicated NMEA port.

### 5.11 Ground Wiring

All ground wires from the VP-X, trim and flap switches, and panel switches must terminate at the same ground block.

- Connect the two ground wires (J4 Pin 6 and J6 Pin 8) to the firewall or main ground block. Do **not** connect the two ground wires together and then run a single wire to the firewall. Both wires should be connected to the same ground block using an individual connector for each wire.

### 5.12 General Power Wiring

The VP-X has power pins on J3, J4, J5, J6, and two on J7. These pins are all wired the same way. Run a wire, sized appropriately for the current load, from each power pin directly to the load. The connectors on J3, J4, J5, and J6 use the larger terminals and the black connectors, and the wire should be 14 to 22 gauge. The J7 connector uses standard male d-sub pins. The wire on J7 should be 20 to 26 gauge.

The following chart should be used to size wires.

Up to (amps)	Use wire size (AWG)
5A	20
10A	18
15A	14
Data signal	22
Trim & flap switch	22
Switches 1 – 10	22

The pin number is shown next to the hole where the wire is inserted on each connector.

- For each power pin, install a wire from the VP-X connector to the device. Use the Load Planning Worksheet as a guide.

### 5.13 Trim System Wiring

The VP-X controls the trim motor as well as provides the circuitry to report the trim position to the EFIS. It also handles runaway or faulted trim conditions, and enables the EFIS to control the trim from the screen. All of the trim wiring is connected directly to the VP-X, and the trim position is reported to the EFIS over the serial data line.

Do not use the trim position inputs on the EFIS. No external relays or switches are required between the trim servo and the VP-X.

Most experimental aircraft use trim servos from the Ray Allen Company (<http://www.rayallencompany.com>). These servos are self-contained units that include the trim motor as well as a position sensor. These servos are designed to run at 14 volts, and the VP-X provides regulated 14v power to the trim motors so they can operate safely in 14v or 28v systems. The general principles described in this section apply to other brands of trim motor as well.

The Ray Allen trim servo (models T2-7A-TS, T2-10A-TS, or T3-12A-TS) has five 26ga wires, as shown in the diagram below:

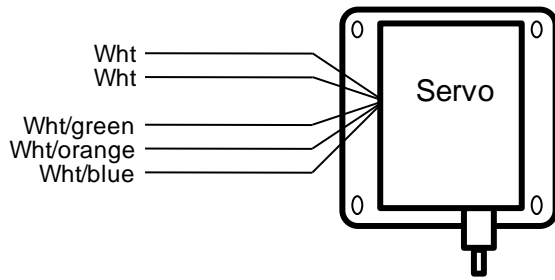

The trim motor itself is driven by the two white wires. It does not matter how they are connected, as the polarity can be changed in the setup menus. The direction of travel is controlled by reversing the positive and negative connections to the trim motor. This is done conventionally using switches or relays, but is done in the VP-X with solid-state circuitry.

The position sensor uses three wires to determine the position of the sensor within the servo – white/green, white/ orange, and white/blue. The three wires are connected within the servo to a potentiometer, and are wired directly to J7 on the VP-X. The connections are detailed in the Load Planning Worksheet.

You can wire trim switches for the pilot and, optionally, for the co-pilot. The trim switches should be momentary action so the trim motor runs only when the button or lever is pressed. You can use either an SPST momentary action button OFF-(ON) or an SPDT momentary action switch (ON)-OFF-(ON), with a middle OFF position.

Each trim axis requires two input pins: one to command trim in one direction, and one to command trim in the opposite direction. No external relays, modules, or indicator lights are required.

You may optionally wire a master trim disconnect switch in series between the VP-X and the trim motor.

The diagram shows the general wiring layout. It is repeated identically for both pitch and roll.

### Wiring pilot trim switch only

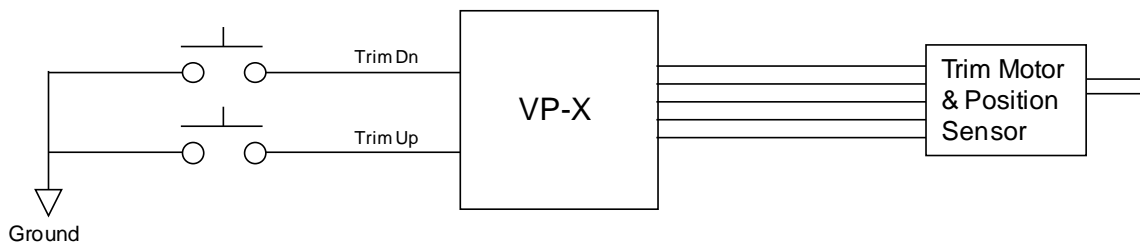

### Wiring pilot and co-pilot trim switches

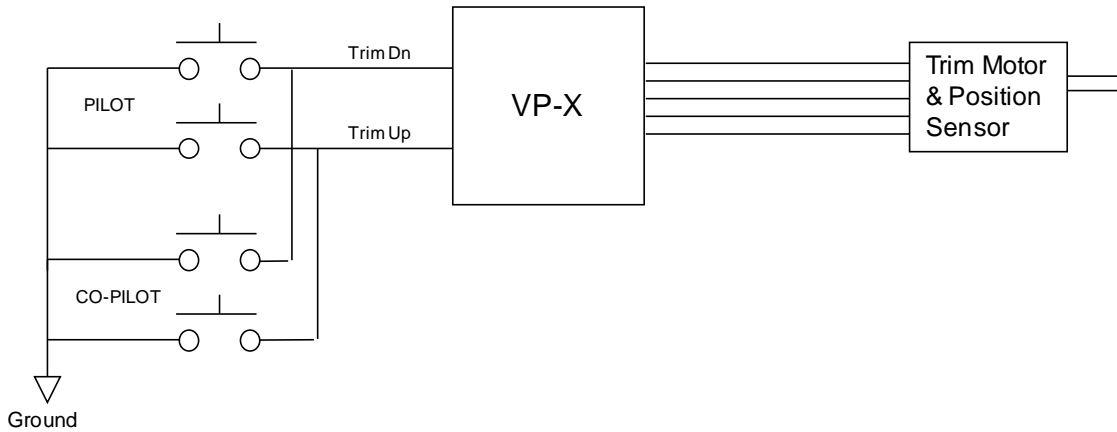

### 5.13a Pitch Trim Wiring

The trim wires are grouped together by trim function, and shown on the Load Planning worksheet. They are separated from each other by number, but are physically located next to each other on the connector. Each trim servo has five wires: two for motor power, and three for position feedback.

Pitch Trim

Function	VP-X Pin	I/O
+2.5 reference voltage (wht/blu)	J7-24	O
Ground (wht/org)	J7-25	--
Position feedback (wht/grn)	J7-26	I
Trim motor (wht)	J7-6 (connect either way)	O
Trim motor (wht)	J7-7 (connect either way)	O
Pitch Trim Up switch input	J7-18	I
Pitch Trim Down switch input	J7-19	I

Connect the wires for the pitch trim system as follows, if installed:

- Run the 5-conductor wire (five wires bundled together) to the trim motor. The colors on the wiring harness match the colors on a Ray Allen sensor and can be connected color to color. Note: in some aircraft, it is desirable to provide a connector near the elevator trim servo. A popular method is to crimp d-sub connector terminals (machined barrel, mil-spec) to the servo wires and to the wiring harness. First, slip a piece of large heat shrink tubing over the wiring harness and move aside for later. Then, connect the terminals on each wire pair and seal with heat shrink tubing, which insulates as well as provides a secure connection. Be sure to offset each terminal so that the bundle doesn't get too big. Cover the bundle of wires with the large heat shrink tubing.
- Connect the switch input pins to the trim switch (pilot and co-pilot). Connect the other side of the switch to ground.

### 5.13b Roll Trim Wiring

The trim wires are grouped together by trim function, and shown on the Load Planning worksheet. They are separated from each other by number, but are physically located next to each other on the connector. Each trim servo has five wires: two for motor power, and three for position feedback.

## Roll Trim

Function	VP-X Pin	I/O
+2.5 reference voltage (wht/blu)	J7-3	O
Ground (wht/org)	J7-4	--
Position feedback (wht/grn)	J7-5	I
Trim motor (wht)	J7-22 (connect either way)	O
Trim motor (wht)	J7-23 (connect either way)	O
Roll Trim Left switch input	J7-16	I
Roll Trim Right switch input	J7-17	I

Connect the wires for the roll trim system as follows, if installed:

- Run the 5-conductor wire (five wires bundles together) to the trim motor. The colors on the wiring harness match the colors on a Ray Allen sensor and can be connected color to color.
- Connect the switch input pins to the trim switch (pilot and co-pilot). Connect the other side of the switch to ground.

### 5.13c TruTrak Auto Trim Module

Follow the diagram below if installing the Tru Trak auto trim module.

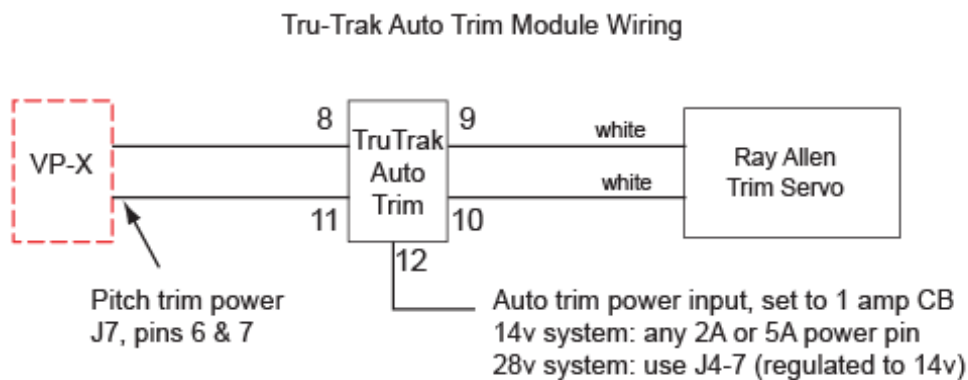

Note: there is some ambiguity in the TT manual regarding the functions of pin 12 and 13. These pins are tied together internally in the TT auto trim module.

### 5.13d Co-Pilot Disconnect Switch

A co-pilot disconnect function can be implemented by installing a switch to disconnect the common ground wire to the co-pilot stick.

### 5.13e Wiring a third trim motor

If you want to control a third trim motor, you can wire the third motor in a conventional manner and source circuit-protected power from one of the VP-X power pins (set circuit breaker value to 1A for this circuit). The diagram below shows a generic implementation.

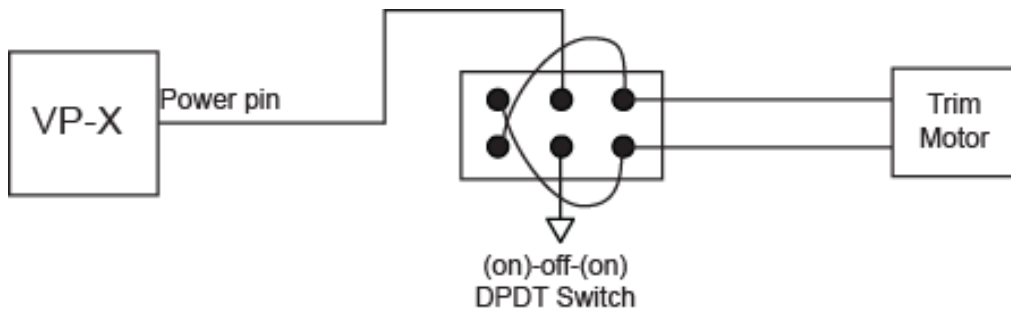

Note the above diagram is for a single switch. The complexity increases if you want to wire a pilot and co-pilot switch as well. In deciding which axis to wire using this method, we recommend considering the following:

- There is no third-axis position indicator unless you install one separate from the VP-X
- You have only one switch to control this axis to keep wiring simple
- There is no backup control from the EFIS for this axis

#### 5.14 Flap System Wiring

The VP-X controls the flaps and provides circuitry for the flap position sensor. The flaps can be configured to run either:

1. Momentary – flaps only run when the flap switch is pressed. A position sensor is optional.
2. Position – flaps run down to the next position when the flap switch is pressed. Flaps run all the way up when the flap switch is pressed. A flap position sensor (Ray Allen POS-12) is required for this option.

You do not need to install the Van’s Flap Positioning System (FPS) or any type of third-party flap controller module.

Flap Position Sensor (optional)

Function	VP-X Pin	I/O
+2.5 reference voltage (wht/blu)	J7-10	O
Position feedback (wht/grn)	J7-28	I
Ground (wht/org)	J7-29	--

Flap Motor and Switch Inputs

Function	VP-X Pin	I/O
Flap motor	J3-1 (connect either way)	O
Flap motor	J3-2 (connect either way)	O
Flap Up switch input	J7-14	I
Flap Down switch input	J7-15	I

You can wire a flap switch for the pilot and, optionally, one for the co-pilot. The flap switch must be an SPDT momentary action switch (ON)-OFF-(ON), with a middle OFF position.

Do not install a flap switch that stays in the UP position.

The flap switch has three pins: a common, one to command flaps up and one to command flaps down.

Both flap motor pins on the VP-X (J3, pins 1 & 2) are wired directly to the flap motor. The polarity of the wires does not matter, as it can be changed in the setup menus.

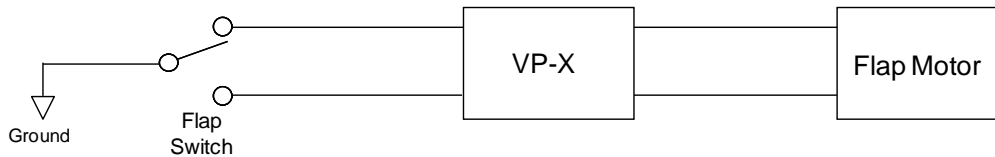

RV flap system: Do not install the Van’s Flap Positioning System (FPS). If you want intermediate stops or flap position feedback on the Display Unit, install a Ray Allen POS-12 position sensor, available from <http://www.rayallencompany.com/products/indsens.html>.



You can purchase a clevis/pushrod kit from your local hobby shop, as the Ray Allen kit is not for use with the POS-12.

### Where to mount the POS-12:

The POS-12 should be mounted so that a pushrod can be attached to both the POS-12 and to the bell crank on the flap system. The pushrod should be mounted a certain distance away from its center of rotation so that the position sensor arm moves 1 inch as the flaps move through their entire range of travel. This distance can be found through trial and error.

The flap motor is powered through the J3 power connector, and the position feedback is connected through the J7 d-sub connector. Connect the flaps as follows:

- Connect J3 Pins 1 & 2 to the flap motor. Each pin goes to one of the two wires on the flap motor. The polarity does not matter and is set using the setup menus.
- If installing a linear flap position sensor, connect J7 Pins 10, 28, 29 to the sensor. The colors on the wiring harness match the colors on a Ray Allen sensor and can be connected color to color. If you are not using a Ray Allen sensor, the function of each wire is detailed in the table above.
- Connect J7 pins 14 & 15 to flap switch or switches. Connect the common terminal on the switch to ground.

### 5.14a Flaps System With Limit Switches

Use a 10A power pin to provide circuit-protected power and wire the flap switch, flap motor and flap motor limit switches per the wiring diagram provided by the airframe manufacturer. The flap motor wires on J3-1, 2 and flap switch inputs on J7 are not used.

A flap position sensor can be installed and wired as described above (to show flap position on the EFIS).

### 5.15 Panel Switches Wiring

The VP-X turns power pins on and off based on external switches. Each switch is wired to a discrete input on the VP-X and to ground. When the switch is closed, it grounds the input pin on the VP-X, signaling the VP-X to turn on the power pins that are assigned to that switch. You can have any number of power pins associated with a switch. For example, a switch can be labeled “Avionics Master” and then all the power pins wired to the avionics can be assigned to that switch. Another

switch can be labeled “Strobe Light” and the power pin going to the strobe light can be associated with that switch.

The Load Planning Worksheet includes a column where you can specify the switch association with each pin.

The VP-X performs the actual switching function. There is almost NO current going through the panel switches. Therefore, you can use any type and style of switch that you like.

The table below shows the switch inputs and the associated pin.

Function	VP-X Pin	I/O
Switch 1 Input	J7-11	I
Switch 2 Input	J7-12	I
Switch 3 Input	J7-21	I
Switch 4 Input	J7-27	I
Switch 5 Input	J7-30	I
Switch 6 Input	J7-33	I
Switch 7 Input	J7-34	I
Switch 8 Input	J7-35	I
Switch 9 Input	J7-36	I
Switch 10 Input	J7-37	I

### 5.15a Standard Switches

The diagram below shows how to wire a switch or group of switches. While there are ten switch inputs, you can use only the inputs that you need and leave the unused inputs unconnected.

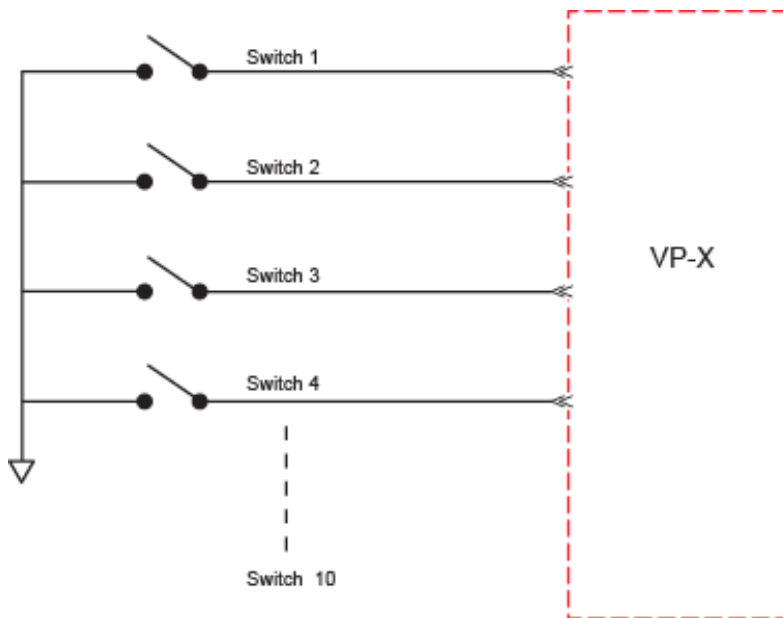

- Wire each switch to an input on the VP-X.
- Wire the other terminal on each switch to ground. Use the same ground block as the VP-X ground wiring.

### 5.15b Alternator switch

If installing a single alternator, the alternator switch can be a simple on/off switch (SPST) wired to one of the inputs. You then associate (in the setup menus) the Primary Alternator pin (J3-5) with that switch input.

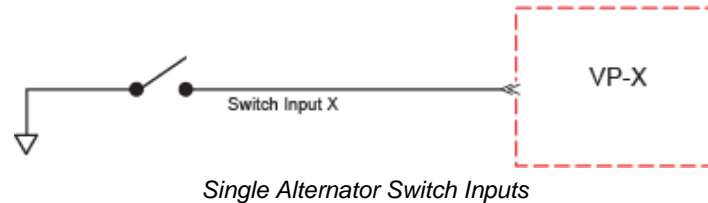

If installing primary and backup alternators, you should use a switch that mechanically allows either one to be on, but not both at the same time, and has a center off position. We recommend a SPDT ON-OFF-ON switch for this purpose. The VP-X does not allow both alternators to run simultaneously.

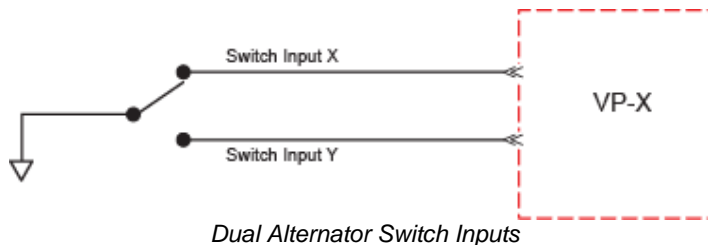

- Wire the alternator switch(es).

### 5.15c Boost pump switch

If installing a single-speed boost pump (for most Lycoming, Jabiru, and Rotax engines), the boost pump switch can be a simple on/off switch (SPST) wired to one of the inputs. You then associate (in the setup menus) the boost pump power pin with that switch input.

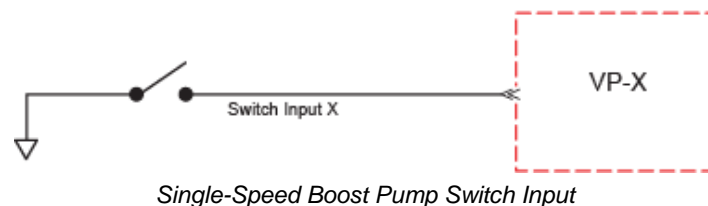

If installing a two-speed boost pump (commonly used on Continental engines), use a switch that mechanically allows either one to be on, but not both at the same time, and has a center off position (SPDT ON-OFF-ON). A locking toggle switch is recommended so that the high boost does not accidentally turn on in flight. There are two ways to wire a two-speed boost pump, shown below:

Two-speed boost pump option 1: Use a single power pin, set to “always on” and then wire the switch in-line between the VP-X and the boost pump. The advantage of this option is the minimal use of inputs and outputs, but the switch does have to be rated to carry the current load of the pump.



Two-speed boost pump option 2: Use two switch inputs and two power pin outputs to run the pump. The advantage of this option is the switch does not have to be rated to carry the current load of the pump, but it does use extra inputs and outputs.

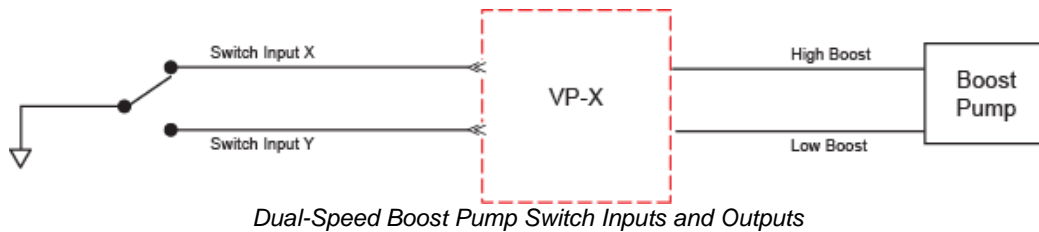

- Wire the boost pump switch.

#### 5.15d Dimmer wiring

Wire the dimmer in-line between the VP-X and the device, such as a load. Ensure the rheostat is sized appropriately for the electrical load.

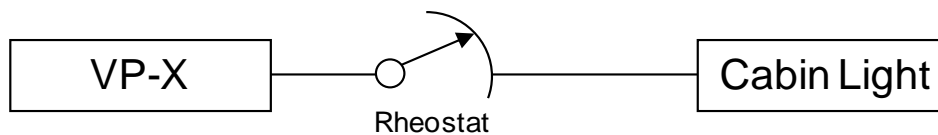

#### 5.15e Mag switch wiring

The mag switch, which is wired to the p-lead on the magneto or electronic ignition, is separate from the VP-X. Follow the ignition manufacturer's instructions for wiring.

- Wire the mag switch.

#### 5.16 P-Mag wiring

P-mags are wired to the mag switch, allowing you to disable the ignition as part of the run up checks. You may also want to disconnect power individually to each p-mag to test the power-off operation during run-up. You can do this by installing a switch in-line between the VP-X power pin and each p-mag. Configure each power pin to be always on later in the setup menus.

- If installed wire the starter/mag switch to the p-leads on the p-mag(s).
- Two options to power the p-mag(s):

1. Wire the power to the p-mags, installing a switch in between the p-mags and the VP-X.

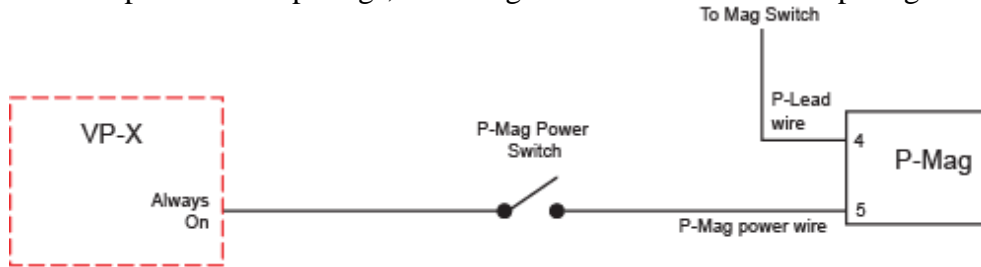

2. Power the p-mag using a straight power wire and controlling it via a standard switch wired to a switch input.

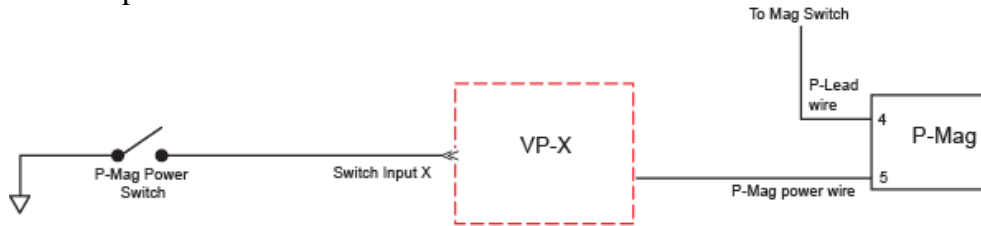

## 5.17 Backup Circuits

The backup circuits allow you to wire backup power directly from the battery, through an external fuse and switch (separate from the VP-X), and then to the device. Each circuit can provide backup power to a device regardless of whether the VP-X is on or off.

### 5.17a Backup Circuit Considerations

There is a great deal of subjective decision making that goes into determining the number of backup circuits to wire. Backups are not uncommon in other systems on the aircraft. For example, the old vacuum-drive attitude indicator had an electric turn and bank instrument for backup. A modern glass EFIS is often installed with backup altitude, attitude, and airspeed round-dial gauges. You have two magnetos for redundancy, and if one fails in flight you can safely land at a nearby airport. But, if one fails on the ground you would not likely takeoff with only one operating.

On one hand, backup circuits add more redundancy, but on the other add more complexity and failure points. Ultimately, you as the builder should do what you are most comfortable with based on your mission and aircraft. Here we will provide a few data points to help in your thinking and planning. They are not absolute or regulatory, only suggestions for thought.

There are two types of failures to consider. One type of failure occurs on the ground and prevents you from flying. The other type of failure occurs while you are flying and may be harmless or could require you land at the next opportunity.

With regard to failures on the ground that keep you from flying: there are many single-points of failure that exist on aircraft today. Would you start the engine or take off if any of the following conditions existed:

- Failed EFIS, AHRS, or engine monitor?
- Failed ignition or magneto?
- Leaky brake o-ring or tire inner tube?
- Starter failure causing you to hand-prop the engine?
- Failed alternator or battery contactor?

The point is there are many single points of failure that can keep you from flying, and the safest thing to do is fix the problem while you are on the ground. It's common sense to always have a Plan B if your plane breaks while you are away from home. With that in mind, the VP-X should not be thought of any differently than any other component that may ground you if it fails. While you can wire backups for the starter and alternator field to get you home, it may be overkill considering that there are many other components on the plane that are likely to ground you as well. Do you have two sets of engine instruments installed, including dual sensors for everything?

The other failure mode occurs when you are in flight. Perhaps the most critical is a backup for the attitude source. The others will depend on your mission and whether you carry a backup 380mm. radio and/or backup GPS receiver. If you fly only VFR or have battery backups built into the EFIS system, then backup wiring may not be necessary. If you fly IFR, then critical circuits should be protected by backups and engaged prior to entering IMC conditions.

Switches for backup circuits engaged regularly prior to entering IMC conditions should be located on the instrument panel or in an easy-to-reach place. If you choose to wire backups for the alternator field or starter, these can be placed in a hidden location as you would not expect to use them except in the case of a system failure.

There are two different methods to wire backup circuits (simply called Method B or C):

#### 5.17b Backup Method B

Backup capability is the ability to provide power to an electrical device independent of the switching internal to the VP-X.

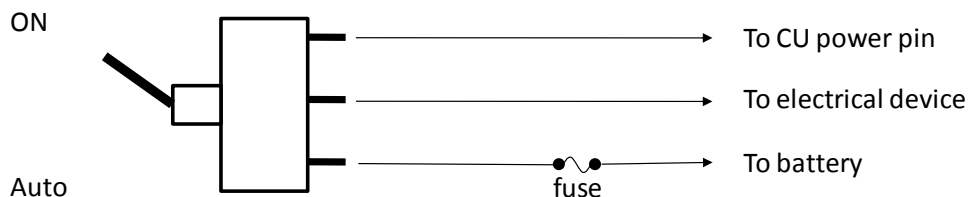

How it works: the switch is normally left in the Auto position, which provides switched power from the VP-X to the electrical device. When the switch is moved to the ON position, uninterrupted power is provided directly from the battery to the electrical device. Make sure the switch and fuse are appropriately rated for the load and wire size. **When battery power is switched on, there is a break in circuit continuity** and therefore you should turn these on at the start of an IMC flight for devices like AHRS, EFIS, GPS, etc. Other devices like boost pump and lighting can cycle power without issue.

Example: You want to add backup capability to the boost pump, which in this example requires a 10A circuit. Wire the boost pump to a 10A circuit on the VP-X via a switch as shown above, and bring in a wire with a 10A fuse directly from the battery.

If you are wiring a backup circuit for an alternator, be sure the alternator or voltage regulator has built-in over-voltage protection. The backup circuit bypasses the OV protection built into the VP-X.

### 5.17c Backup Method C

Many modern EFISs have multiple, diode-isolated power inputs – typically a primary and a secondary power input. The diode isolation ensures that each power input is “independent” of the other power inputs. Method C allows you to wire a backup circuit into the secondary power input on the EFIS (or other device if that is the case) directly from the battery through a fuse and a switch. The EFIS will automatically choose between the inputs and select the one with the highest voltage.

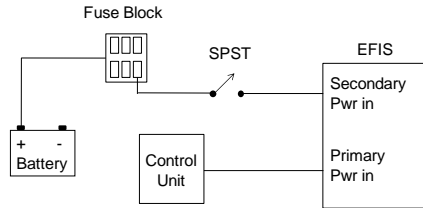

Wire a fuse or fuse block near the battery. Size the fuse for the wires and as per recommended by the EFIS manufacturer. Then wire to an SPST switch. The switch should be labeled Auto (down) and On (up). When the switch is off, power will be sourced from the VP-X. When on, power will be sourced either directly from the battery bus or the VP-X.

### 5.17d Do not wire backups this way

Do not wire other circuits so that battery power is provided directly to the device, as illustrated in the diagram below.

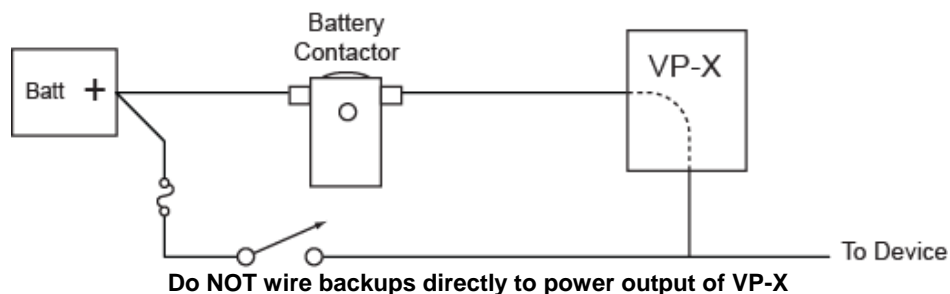

Doing so may cause unreliable operation and may blow the fuse under certain circumstances.

### 5.17e Aft-mounted battery considerations

If the battery in your aircraft is mounted in the aft section of the aircraft, you must take special care to route the backup switch wiring because the routing is longer than for front mounted batteries. You may want to consider running a slightly larger wire to account for the additional length. FAA AC 43.13-1B includes a chart (figure 11-2) to determine the wire size.

Another consideration is that the relatively long length of wire must be protected from short circuits. There are two options to choose from:

1. run each backup wire to the back, and to an individual fuse in a fuse block. Have a fuse block in back with a short wire (perhaps 12ga) to the battery. You don't need to protect the 12ga wire because it is so short. If a wire running to the front shorts, you lose just that circuit.
2. run a larger wire from the back to the front. Install a larger fuse in the back to protect the long run to the front, then smaller fuses in the fuse block up front for each backup circuit. However, if the larger fuse blows all the backups fail in one shot.

Keep in mind these are backup circuits and normally only used when the primary switching method fails. Choose the option that works best for your mission and personal assessment of merits of each.

The diagram below shows the relative layout of the backup circuit components. Note that the fuses (or breakers) are in the back near the battery, providing protection for the wire run forward.

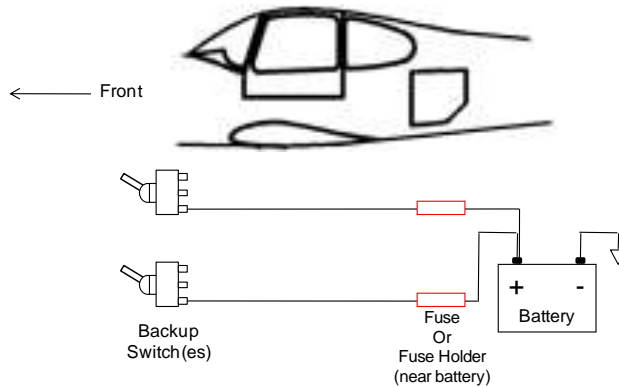

### 5.18 Aux Battery Wiring and Voltage Measurement

Function	VP-X Pin	I/O
Aux battery voltage measurement	J5-11	I

This pin measures voltage and reports it to the EFIS for display. A resistor should be placed in-line near the aux battery to provide circuit protection for the wire.

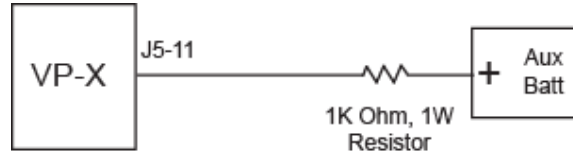

- Install a 20 or 22 AWG wire from J5-11 to the aux battery positive terminal. Install a 1K Ohm, 1 watt resistor in-line near the battery.

There are several ways to wire an aux battery, depending on your application. You can install an aux battery contactor to connect or isolate the aux battery from the main bus. The aux battery can also be charged using a diode (this option should be used only when small switched loads are attached to the battery).

### 5.19 Items you don't have to wire to the EFIS

The following items are traditionally wired directly to the EFIS (optional of course) but are now integrated into the VP-X and the corresponding information is sent over a data line from the VP-X to the EFIS. Therefore, these connections are no longer needed at the EFIS.

- Shunts or hall-effect sensors to measure current
- Trim indicator wires
- Flap indicator wires

## 5.20 Retractable Gear Wiring

The VP-X provides a source of circuit protected power for the gear switch. Wire the gear system per the airframe manufacturer's instructions.

## 5.21 Testing Individual Circuits

At this point, all the power wires should be connected to their respective devices. The purpose of this step is to verify correct installation of the wiring.

*Taking your time and being methodical on this step will save troubleshooting time later.*

**Warning:** make sure that the following are carefully checked prior to proceeding:

- Disconnect the large wire going to the starter to eliminate any chance that the starter may be accidentally engaged. Temporarily cover the exposed end of the wire with electrical tape.
- Make sure that the propeller area is clear and can rotate freely.
- Verify that the fuel system is sealed or empty.
- Verify that the area around and under the flaps is clear.
- Verify that the area around the trim motors and tabs is clear.
- Verify the high-voltage strobe wiring is either sealed or connected to a strobe light.
- Check for any other conditions that may be problematic during testing.

**NOTE ABOUT MEASURING VOLTAGE:** Solid-state switches have a characteristic that will show near bus voltage on a power pin even when that pin is off. Don't worry, it won't cause sparks or arcing. There is no "power" behind the voltage, it is simply an artifact of the solid-state switches (a specialized transistor). In order to measure voltage correctly, there needs to be a load on the pin, like a test lamp, when taking measurements. If the pin is off, the voltage will be zero when there is a load on it. If the pin is on it will read at bus voltage when there is a load on it.

Then proceed with the following steps:

- Turn off the master switch.
- Disconnect the wiring harness connectors from J3, J4, J5, J6, and J7 on each VP-X.
- Verify that the correct wire is in the correct connector location using the Load Planning worksheet as a reference.
- Prepare test leads for the d-sub connector using two 20 or 22 gauge wires about 10ft long each with a female d-sub connector terminal crimped on one end and an in-line 2A fuse on the other.
- Prepare test leads for the power connectors using the test leads in the wiring harness kit, attach spade terminals to an appropriately rated blade fuse and then to the battery or hot wire. Using a bare-end wire, paperclip or screwdriver rather than the male terminal on the test lead may damage the gold coating on the terminals inside the connectors.

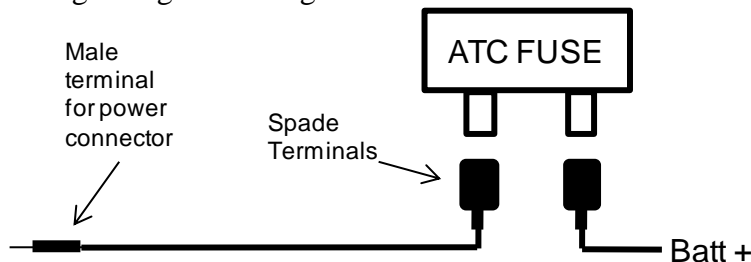

- Using the fuse-protected test lead, connect one wire to the positive terminal of a battery (any battery is OK as long as it matches the voltage of the aircraft battery). Check that the negative on the battery is attached to the ground terminal or airframe.
- For each 5A, 10A and 15A circuit, push the male terminal from the test wire into the connector (the female connector with the wires going to it) and verify the device turns on. Note that certain devices may have multiple independent power inputs, like a Garmin 430 or SL-30. **CONNECT THE TEST LEAD TO THE FEMALE CONNECTOR WITH THE WIRES GOING TO IT, NOT THE MALE PINS ON THE VP-X.**
- Insert the wire into J3 Pin 4 and turn the starter switch and verify starter contactor operation by an audible click.
- Connect the other wire to ground. Insert the wires into J3 Pin 1 and Pin 2 and verify the flap motor operates through its expected range of motion. Flipping the pins will change the direction of the motor.
- Verify correct operation of the master switch. The contactor should click closed when the switch is on.
- Using an ohm meter or test lamp, verify each of the two ground wires is grounded properly.
- Using the 22 gauge wire with the female d-sub terminals, connect one wire to the positive terminal of a battery (any battery is OK as long as it matches the voltage of the aircraft battery). Check that the negative on the battery is attached to the ground terminal or airframe.
- Connect the other wire to ground. Insert the wires into the correct trim motor power terminals and verify the trim motor operates through its expected range of motion. Flipping the pins will change the direction of the motor.
- Verify each of the devices connected to the 2A circuits powers on when the test lead is connected to J7.
- Using an ohm meter or test lamp, verify each of the pins coming from a panel switch is grounded when the switch is turned on.
- Turn off the master switch, if on.
- Remove any test leads and do a sweep to check for loose or exposed wires. Leave the large wire to the starter disconnected until asked to re-connect in the ground testing phase.

You are now ready to power up the system.

- Connect J3 – J7 to the VP-X.
- Turn on the master switch to turn the system on. On a new VP-X, the EFIS power is set to “always on” until you assign it to a switch. The switches and other functions will not work until the system is configured.

Note: If you notice anything unusual, turn off the master switch immediately.

## 6 Configure the System Settings

You are now ready to configure the VP-X to operate in your particular aircraft. This section describes each part of the setup process.

Configuration for the AFS and GRT EFIS is done using the EFIS which is connected to the VP-X and configuration for the MGL EFIS is done using the PC configuration application. Details are described below. The VP-X comes from the factory with no switches operable, the trim and flaps are disabled, and the circuit breaker values set to 2 amps. Therefore, the system needs to be configured before it can be operated.

Use the Load Planning Worksheet as your guide during setup.

Access the setup menus via the setup menus in the EFIS. Since each EFIS is different, this section describes the generic steps you should follow during setup.

#### **6.1a GRT HX:**

- Configuration is performed from the EFIS setup menus.
- The VP-X electrical page is the third page on the engine screens.
- You must have demo mode turned off to change configuration settings.
- VP-X settings are under Display Unit Maintenance -> VP-X Configuration.
- Each setup page has a system configuration status item, this will indicate that the value is saved properly, or an error if there is a problem saving that data item.
- In setup, devices are saved right after the value is changed with the rotary knob. Hitting save will save all configuration data and kick you back out to the main screen (so don't do this till you're done).
- All of the VP-X status data is sent over the DU-interlink. For config data, only the names are sent over the link. On/Off, Reset, and Wig Wag mode commands are sent over the link. The VP-X Electrical page works on other displays except for some config data and the flap/trim move commands.
- The trim and flap indicators automatically use VP-X data (rather than the analog inputs) when VP-X trim and flaps are enabled.
- Settings can be saved to the DU (but not to the USB drive) and subsequently restored to the VP-X. This function is in the main VP-X setup menu.

#### **6.1b MGL:**

- The MGL is configured via the VP Configurator application for use with Windows computers. The PC Configurator application is available on the VP web site under Support/Software. The VP-X must be connected to the PC for configuration. Some earlier versions of MGL software have configuration code in it, but do not use this.

#### **6.1c AFS:**

- Configuration is performed from the EFIS setup menus.
- Settings can be done on any EFIS if you have a multi-screen EFIS.
- VP-X settings are found under: CHECK -> MAINT. -> ADMIN -> CALIBRATION (hold 2 secs) then go to:
  - 1. System Admin – On the EFIS that is physically connected to the VP-X, set the designated serial port to “VPX”
  - 36. VP-X Configuration. Settings can be done on any EFIS if you have a multi-screen EFIS. Configure each of the devices as described below.
- To show trim and flaps on a specific screen, the trim and flap indicators must be turned on for that screen.
- Settings files can be exported and imported using Admins Settings -> Transfer files To/From SD card -> VP-X Config & Cal file.

#### **6.1d Switch Input Verification**

In the EFIS setup is a screen that shows the status (on/off) of each of the switches.

- Turn each switch on and verify the display shows that switch is on.
- Turn each switch off and verify the display shows that switch is off.

### 6.1e Avionics, Lights, etc.

Each device (lights, transponder, radio, EFIS, etc.) that is powered by the VP-X must be configured to operate correctly. Configure each device as specified in the Load Planning Worksheet.

- Configure each of the electrical devices using the EFIS setup menus.

### 6.1f Alternator – Primary and Backup

The primary alternator must be on J3-5 and is configured using a unique setup screen.

- Configure the over-voltage trip level. Set to 16v for 14v systems and 32v for 28v systems.
- Configure the primary alternator pin using the EFIS setup menus.

The backup alternator can be on any pin except a wig-wag pin, starter, EFIS, or 3A output 1 . If the backup alternator is installed:

- Configure the backup alternator pin.
- Set which circuit is the backup alternator. This must be specified or the overvoltage protection and lockout protection on the backup alternator will not work.

### 6.1g Starter

- Configure the circuit breaker value for the starter circuit.

### 6.1h Trim

You can run the trim from both a trim switch as well as from the EFIS.

The trim switches will only run the trim motor if the trim position is within the defined limits. If for some reason the trim goes out of the limits, you can run the trim back within the limits, but not further out of limits. When you run the trim from the EFIS, the end point limitations are ignored so you can freely move the trim motor before the settings are configured.

The position sensor range is 0 to 255. The limits are set numerically based on actual feedback from your sensor. Below is a diagram showing what some typical limits may be:

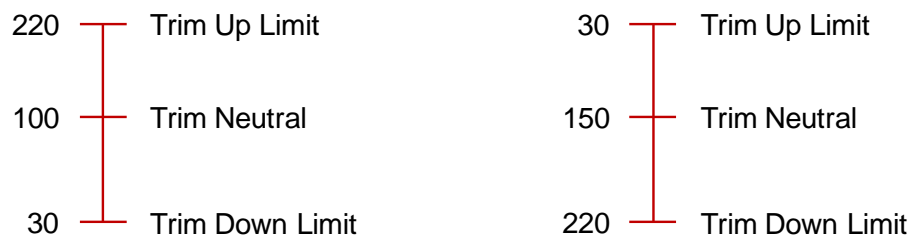

Depending on your installation the up limit, for example, may be a high number or a low number. The actual number is irrelevant – it simply refers to a trim position.

The limits can be used to set the maximum travel of the trim. For example, you may want to limit the down travel of the trim and you can do so by configuring a value that is within the mechanical travel limits.

The Ray Allen trim servos automatically stop at the mechanical limits of travel.

Each of the two trim setup pages is similar. Repeat the follow for both the pitch and roll trim.

**Verify that each trim switch is in the neutral (middle) position,  
and that the area around the trim motor/tabs is clear before starting configuration.**

**When operating the trim motor for the first time, carefully check  
that airframe components don't bind or bend under the motor load.**

The following trim items can be configured:

Motor polarity	Standard/Inverted. Press the Up or Down soft key, and the trim should move in the appropriate direction. If not, change the polarity until the trim runs in the correct direction. Down trim is usually the forward switch, and trim up is usually the aft switch. The elevator trim tab should run down when pressing the up trim button.
Up limit	Run the trim all the way up using the Up soft key. Note the number that shows the trim position (should be on the screen, between 0 and 255).
Neutral position	Run the trim to the neutral position using the Up/Down soft keys. Note the number that shows the trim position (should be on the screen, between 0 and 255).
Down limit	Run the trim all the way down using the Down soft key. Note the number that shows the trim position (should be on the screen, between 0 and 255).

#### *Variable Trim Speed (Pitch only)*

Reduce Power above	Set the indicated airspeed <u>above which</u> the pitch trim runs at a slower speed.
% Power	Set the percentage of full speed that the pitch trim motor should run when the aircraft speed is above the 'reduce power above' speed. 70% is a good starting point. Range is 40% to 90%. Set to 0 to disable this feature.

- Configure the pitch trim settings so they match your desired final configuration. Press SAVE.
- Configure the roll trim settings so they match your desired final configuration. Press SAVE.

### **6.1i Flaps**

You can run the flaps from both the flap switch as well as from the EFIS.

The flap switch runs the flaps either in either momentary or position mode (see below). When you run the flaps from the EFIS, the flaps only run while the flap control button is pressed.

**Verify that the flap switch(es) is in the neutral (middle) position, and that the area around the flaps is clear before starting flap configuration. When moving flaps for the first time, carefully check that airframe components don't bind or bend under the motor load.**

The following flap items can be configured:

#### *General Configuration*

Flap enable	Enable/Disable. Set to enable if the VP-X controls the flaps. Set to disable if your flaps are not directly controlled by the VP-X.
Flap control	Position/Momentary. Position=flaps can be set to stop at intermediate positions (requires position sensor). Momentary=flaps run only when flap switch is pressed. <b>Set this to Momentary for now.</b> You can set it to position once the initial engine and airframe testing is complete. This is because the position setting may operate differently in the air than on the ground (due to air loads) and fault the flap circuit due to motor run-on. We recommend deferring this uncertainty until later in the flight test period.
Circuit breaker	Set the circuit breaker value for the flap motor circuit.
Motor polarity	Standard/Inverted. Press the Up or Down soft key, and the flaps should move in the appropriate direction. If not, change the polarity until the flaps run in the correct direction.

Note: The Up/Dn and midpoint limits only need to be set if a position sensor is installed.

Up limit	Run the flaps all the way up using the Up soft key. Note the number that shows the flap position (should be on the screen, between 0 and 255). We recommend setting it a few numbers short of the actual limit to allow for position slop.
Midpoint A/B	Allows you to set intermediate flap stops. These are disabled when the flap control is set to Momentary. Disregard for now. Note: if these are set to non-zero values, they must be in numerical order consistent with the up and down limits or an error occurs during save.
Down limit	Run the flaps all the way down (or the desired end point) using the Down soft key. Note the number that shows the flap position (shown on the screen, between 0 and 255). We recommend setting it a few numbers short of the actual limit to allow for position slop.

Note on up and down limits: make sure the limit value (the number 0 - 255 corresponding to the position) is set before or at the point of the physical limit. For example, if the down limit value is set to 0, but the furthest it goes is down to 8, then it will never reach zero and continue to drive the motor in anticipation of reaching zero. When then *max travel time* triggers, then the circuit will fault.

End point extent	Only applies if Flap Control is set to <i>Position</i> . Time in seconds that the flaps will run extra when at the top and bottom travel limits. This is to eliminate the slop inherent in the position sensor, which is used to stop the flaps at the top, bottom and intermediate position. We recommend this is set to about 0.5 seconds.
------------------	--

Use the example below to see how using this feature can eliminate slop in the position sensor. For the settings at both the top and bottom stops, you should set the value so some number “inside” the range so that the sensor will cause it to stop early, then the *end point extent* time will run the flaps to the end. Additionally, air loads during flight will likely change the readings somewhat, and this technique will account for that as well. Note that the actual readings may be reversed in your installation.

	Actual Reading	Recommended Setting
Top	→ 12	→ 20
15°	→ 48	→ 48
Not used		0
Bottom	→ 248	→ 240

**Max Flap Speed** The IAS above which the flap down switch is disabled and the flap over speed alarm is triggered. Set this value to 0 to disable both the flap down switch disable function and the flap over speed alarm.

**Over speed Position** The flap position below which the flap over speed alarm is triggered. If the flaps are BELOW this setting and the IAS is higher than the Max Flap Speed, the Flap Over speed alarm is activated. Since each aircraft is different, this speed may correspond to 10° of flaps, or maybe 30°. We recommend you set it somewhere just a bit BELOW the flap up setting. When we say BELOW we mean the actual physical flap position, not the numerical value used to show the position. Here are some examples:

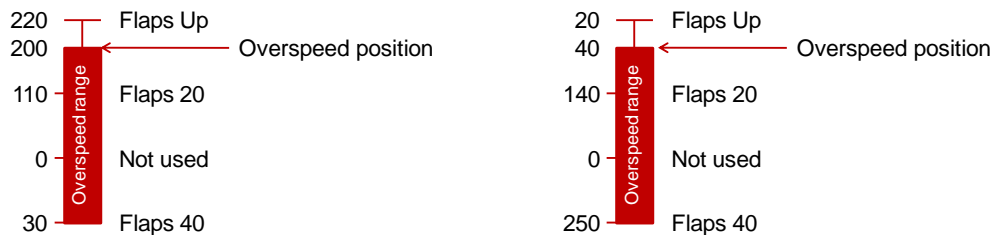

- From the Flap Setup in the EFIS, enable the flap circuit and press save.
- Set the flaps to momentary.
- Set the circuit breaker value.
- Press SAVE. (GRT saves automatically when a value is changed)
- Run the flaps using the soft keys on the EFIS. If the flap motor direction is backwards, change the motor polarity setting. Press Save.
- Run the flaps using the flap switch. If the flaps run backwards, the flap switch inputs are wired backwards.
- Calibrate the top and bottom positions, and optionally the middle stops.
- Press SAVE.

- After the first few flights in the aircraft, go back and update the rest of the settings to your desired configuration.

NOTE: Because air loads on the flaps cannot be simulated on the ground, you may have to modify the limit settings once you begin flight testing. See the troubleshooting section in this manual if your flaps are not operating properly.

NOTE: If the flap motor runs more than 15 seconds, the motor is stopped and a fault is generated.

### **6.1j Wig-Wag**

XeVision HID light customers: Vertical Power has licensed the patented XeVision warm up and pulsing algorithms and therefore the Vertical Power wig wag will not void the XeVision warranty. Set the warm-up period to 30 seconds for XeVision HID lights.

**NOTE:** If your lights have a built in wig-wag circuit, use the functionality in the VP-X. The wig-wag in the VP-X has many advanced features and is designed to work as part of the overall system. We do not recommend using an external wig-wag. Typically, there is a second power pin, a sync wire, and/or a master/slave wire, all of which should not be wired. Wire only the primary power wire on each light.

A pin used for wig wag cannot be set to switch 0 (always off), 11 (always on) or as the secondary alternator.

Do the following to configure wig-wag:

- Select one or more power pins to wig wag, and assign to a wig-wag pin. If only one power pin is selected, it must be assigned to the pin #1 wig wag slot. Set both pins to Disable to disable the wig-wag feature.  
**NOTE:** The pin must be assigned to a switch prior to enabling it for wig-wag.
- Set the indicated airspeed above which the devices will wig-wag. If the lights are turned on below that speed, they will be steady, then wig wag automatically above that speed. If this is set to 0 the pin or pins will always wig wag when turned on (this is primarily so you can test the wig wag feature during the build process).
- Set the warm-up delay. A 5-second delay minimum is required to detect no-current or over-current conditions. We recommend a minimum 30 second warm up period for HID lights. Check with your manufacturer for specific timing.

### **6.1k Aux battery input**

- Enable the aux battery input to display the aux battery voltage on the EFIS.

### **6.1l Starter Annunciator Input**

- Enable the starter annunciator input to display the starter annunciator on the EFIS.  
Note: the annunciator status is sent once per second to the EFIS, so you may not see the annunciator during a quick engine start. The purpose of the annunciator is to show a stuck starter contactor once the engine is running.

### **6.1m Export Settings**

If the EFIS has a method to save the settings, do that now. You can then use these settings to restore your configuration later on if necessary.

## 6.1n Import Settings

You can restore your saved settings using the file previously saved. Refer to the EFIS instructions.

**Do not shut off the system while the import is in progress.**

## 7 Ground Test

The ground test steps are performed in two parts: the first part without the engine running and the second part with the engine running.

### 7.1 Testing without engine running

Perform the following steps without the engine running. The battery will drain during testing, so have either a charger or ground power available.

- With the master switch off, turn on the each backup circuit and verify the respective device turns on. Turn off backup circuits.
- Turn on the master switch
- Verify that each of the switches turns on the expected devices. Wait to test the alternator switches until the engine is running.
- Verify the pilot flap switch operates as expected.
- Verify the co-pilot flap switch operates as expected.
- Verify the pilot trim switches operate as expected.
- Verify the co-pilot trim switches operate as expected.
- Test the runaway trim system. If able, introduce opposite inputs from the same stick or from both the pilot & co-pilot sticks (ie trim up and down at the same time). Verify a fault after 3 seconds. Clear the fault. Verify backup trim operation on the EFIS screen and reset fault. Verify normal operation.
- Verify aux battery voltage display is correct (if installed)
- Turn off the master switch

### 7.2 Testing while engine running

This section verifies the proper operation of the VP-X with the engine running. The main objectives for this section are:

- Verify engine starting and proper mag operation
- Verify starter annunciator
- Verify proper alternator operation

If this is coincident with first engine start, be sure to integrate the kit manufacturer's first engine start safety procedures with the test plan specified herein. You may consider first verifying proper operation of the engine and once that is complete, begin the electrical system test.

Prolonged low-power operation of a new engine may adversely affect the engine. Be sure you understand the engine break-in requirements, and balance those against the time needed to test the electrical system.

These procedures are published as a guideline. Follow the engine manufacturer's starting and safety procedures.

- Ensure that the battery is fully charged. If the voltage drops rapidly during engine start, then the battery is bad or not fully charged.
- Start the engine and verify the starter circuit is operating correctly. If the starter annunciator circuit is enabled, verify the starter annunciator comes on during start.
- Note the bus voltage. Then turn on the primary alternator.
- The voltage should increase to 14.2 volts +/- 0.3 volts (check with your alt manuf for specifics)
- Turn off the primary alternator and note the bus voltage drop to about 12.5 volts.
- Run the engine up to about 1600 RPM and turn on the backup alternator. The bus voltage should increase from about 12.3 volts to about 14.0 volts.
- Turn off all the switches.

## 8 Flight Test

This section verifies the proper operation of the VP-X during flight.

Prior to flight, make sure you understand the following, which is described in the Operating section:

- How to clear faults
- How to switch devices on and off manually
- How the runaway trim system operates

This section provides a series of recommended steps, and you should incorporate these steps into the overall flight test plan as you deem appropriate. Go back and review the ground test steps, as complete and thorough ground testing will mitigate the risk of trouble while airborne.

**Warning:** Do not fly the aircraft until you are comfortable everything operates correctly on the ground, and you are knowledgeable about the systems and their proper operation.

### 8.1 Notes about first flight

It is the pilot's responsibility to develop a test plan that ensures a safe and productive first flight. Typically, the first flight is focused on verifying basic flight characteristics and proper engine operation. With that in mind, we recommend deferring complete electrical system tests until after you are comfortable that the engine and airframe are performing as expected, and you are comfortable flying the aircraft. We recommend the following configuration for first or early flights, and it can easily be changed for later flights:

- Configure the flaps to operate in *momentary* (flaps only move when the flap switch is pressed). It may take a few flights to "dial in" the proper limit settings for *position* (flaps move to next position when flap switch pressed), and you can do that once the basic flight characteristics are proven.
- Be sure to review how to acknowledge and/or reset circuit faults.

If you are installing the system as a retrofit, it is still important to complete as much of the testing on the ground as possible.

### 8.2 VP-X system checkout

Now that initial aircraft checkout flights are complete, you can proceed with the electrical system tests.

Once airborne, keep an eye out for traffic and obstacles during the test procedure. Carry a handheld radio as a backup in case of electrical system failure. If you encounter any difficulties in flight due to improper setup or unknown electrical system behavior, land as soon as practical or simply turn off the

master switch. If you have completed a thorough check out on the ground, the chances of problems while airborne are greatly reduced.

Verify each of the following in flight:

- Verify devices turn on and off when switches are turned on. Looking at the individual current draw is an easy way to verify something is turned on.
- Verify variable speed trim works as configured.
- Verify wig-wag operates as expected.
- Verify flaps operate as expected. The air loads may necessitate minor changes to the flap settings if configured with intermediate flap stops.

## 9 Troubleshooting

Follow these instructions for each system. Please contact Vertical Power tech support at 505 715-6172 if you have any questions.

### 9.1 Flap Configuration

Problem	Solution
Flaps go up, but not quite all the way	<ul style="list-style-type: none"> <li>• Run the flaps using Momentary and verify they operate correctly through the whole range.</li> <li>• If limit switches are installed, adjust them or the linkage so the flaps operate correctly.</li> <li>• If flaps are set to stop at intermediate positions, be aware there is some slop in the position sensor, so you need to compensate for that which can be easily done. The <i>end point extent</i> feature runs the flaps for an extra period of time (configurable) at the up and down limits to make sure they hit their full limits. Use the <i>end point extent</i> setting (under Flap Setup) to run the flaps a little extra, and set the stop limits a bit shy of the ends. For example, if when your flaps are all the way up, it shows the position indicator at 4 (under flap setup). Then set the top limit at 10 and set the end point extent value to 1.0 seconds. This is only an example, but shows that you put some slop in the stop value (10) and then added an extra second of flap motor run time to make sure they go all the way up mechanically.</li> </ul>
Flaps run on and trigger the <i>Max Run Time</i> which causes a fault.	<ul style="list-style-type: none"> <li>• If the flaps are all the way up or down, and slop in the position sensor causes the system to think the flaps have not reached their limits, it will continue to run the motor until it triggers the max run time fault (15 seconds). This is designed to keep the motor from running indefinitely and burning out in such situations. See above for solution.</li> </ul>
Flaps worked fine on the ground but faulted in the air.	<p>Since the air load on the flaps cannot be simulated on the ground you may have faults in the air until you “dial it in”. Check:</p> <ul style="list-style-type: none"> <li>• Circuit breaker value for the flap circuit. The current draw is higher in the air than on the ground.</li> <li>• Sensor slop which may cause faults mentioned above.</li> </ul>

Flaps **work in momentary but do not work when set to position** (intermediate flap stops). Please follow these steps carefully in the order shown:

1. In the setup menus, set the flap system to ‘momentary.’ Set End Travel to 0.5. Press Save. Move the flaps to the middle of their travel. Turn off power.
2. Remove J7 (37 pin d-sub connector) from the VP-X. Verify the flap switch input pins are correct on the male J7 connector (the one connected to the wires). Verify J7 pin 15 is grounded when the flap switch is pressed down. Verify J7 pin 14 is grounded when the flap switch is pressed up. It is easy to wire this backwards. Swap the wires if they are incorrect. Reinstall J7 and turn power on.
3. Press the flap down switch and the flaps should run down. If not, change the motor polarity in the setup menus so that the flaps run in the correct direction.
4. Now the switch inputs and the motor direction are correctly wired and configured. The next step is to verify the position feedback is correctly calibrated.
5. On the EFIS display verify the flap indicator corresponds to the actual position of the flaps. If the display shows down when the flaps are up and vice versa, the top and bottom limit settings must be changed in the setup menus. Internally, the flap position is reported using a number range from 0 to 255. Sometimes a low number means the flaps are up and sometimes a high number means the flaps are up. Each installation is different. You must set the limits to match your installation. Please see the flap configuration section earlier in this manual for the correct steps.
6. Once the new values are entered and saved, verify the flap position indicator reads as expected. The position indicator on the display should just reach UP when the flaps are all the way up, and should just reach DOWN when the flaps are all the way down. Leave the flaps in the middle of their travel range.
7. Go back into setup and change the system to ‘position.’ Set the intermediate stops if desired. Set one or both to 0 if that position is not needed. Press Save and exit the setup menu.
8. Verify the intermediate stops work correctly.

## 9.2 Electrical Configuration

Problem	Solution
Nuisance trips	<ul style="list-style-type: none"> <li>• Verify with the manufacturer of the electrical device that you’ve used the correct circuit breaker value. Do not increase the CB value over what the wire can support. Use these for guidelines: 14 gauge wire – 18A max 18 gauge wire – 10A max 20 gauge wire – 5 A max</li> <li>• If nuisance trips persist, contact Vertical Power tech support.</li> </ul>

## 9.3 Trim faults

Problem	Solution
Trim faults at power on	<p>The trim is designed to fault if any of the trim switches are on at power on.</p> <ul style="list-style-type: none"> <li>• Verify that none of the trim switch input wires are shorted to ground.</li> <li>• Verify that none of the trim input switches are closed.</li> </ul>
Cannot clear a trim fault	<ul style="list-style-type: none"> <li>• A trim switch input line is still grounded. You must un-ground the input and re-cycle power to the system.</li> </ul>

## 10 VP-X System Operation

This section describes the operation of the VP-X. Additional details can be found in the EFIS manual provided by the EFIS manufacturer.

### 10.1 Power On and Off

Turn ON the VP-X by turning on the aircraft master switch.

When turned on, the VP-X performs the following checks:

**Internal data integrity checks.** If it fails the internal data integrity checks, the system resets to its default values and the EFIS turns on to display the specific fault. The switch settings, trim and flaps settings are cleared and do not operate. The EFIS may be able to restore the settings to the VP-X. If this failure occurs please contact VP tech support.

**Trim and flap input checks.** If any of the trim or flap switch inputs are active (ie a trim switch pressed) during startup, the trim circuit shows a fault. You must clear the physical fault (either a stuck switch or shorted wire), then cycle power to the system to clear the fault in the system.

**General fault checking.** If any faults exist on the VP-X at power on, it will automatically turn on the EFIS circuit so that the EFIS can display the fault.

Turn OFF the VP-X by turning off the master switch. Note that backup circuits, if installed, must be turned off as well.

**After turning off the VP-X, wait at least 3 seconds before turning the system back on.**  
This short delay gives the electronics time to discharge and clear properly.

### 10.2 EFIS Electrical System Page

When the VP-X is configured to work with a supported EFIS, the EFIS display includes an electrical system page. Each EFIS is different, but in general the EFIS can:

- Show a list of each of the power circuits, including trim and flap
- Show the status of each circuit, whether on or off or faulted (and type of fault).
- Total current draw of all circuits
- View the current draw, in amps, of each circuit. The minimum detectable amount is 100 ma (1/10 of an amp).
- Allow user to reset a faulted circuit.
- Show graphical electrical system diagram, including main bus voltage and aux battery voltage.
- Show VP-X internal temperature
- Position of each of the switches.
- Allow manual control of each individual circuit, including trim and flaps.

### 10.3 Other VP-X functions

In addition to the Electrical System page, the following data is used by the EFIS and displayed to the user:

- Trim and flap position
- Trim and flap in-motion indicator
- Pitch trim speed, as a percentage of maximum speed

- Wig wag active indicator
- VP-X system faults (see table at end of this document)

#### **10.4 VP-X Configuration**

The VP-X is configured using the EFIS setup menus. For each circuit, configure it as shown in your Load Planning Worksheet, following the instructions in an earlier section of this manual.

#### **10.5 Turning electrical devices on and off**

Devices can be turned on or off in one of several ways:

1. Using the switches wired to the switch inputs on the VP-X.
2. Using the backup switches, if installed.
3. Using the soft keys on the EFIS. This allows you to turn on and off an individual device separately and independently from the switch it is assigned to. Cycling the switch will reset the device back to switch operation. Consult the EFIS manual for specific instructions.

Only one alternator can be on at a time. If both are turned on, then the most recent one to turn on stays on and the other one is turned off.

#### **10.6 Trim and flap operation**

The flaps can be operated by the flap switch or by the soft keys on the EFIS.

The flaps are configured to move in one of two ways:

1. only when the flap switch is pressed, or
2. move to the next down position (and all the way up) with a momentary press of the flap switch.

The trim operates whenever a trim switch is pressed. The trim runs within the limits specified in the trim setup menus. The trim can also be controlled by soft keys on the EFIS. The pitch trim operates at two different speeds, which is controlled by airspeed (as reported by the EFIS).

The EFIS displays the trim and flap position and indicates when either is moving.

The maximum time the flap motor can run per switch input is 15 seconds. This prevents the motor from continuously running if the position sensor should fail or a control wire shorts. If the max run time is exceeded, the flap circuit will fault.

##### ***10.6a Trim switch fault detection on startup***

If any of the trim switch inputs are active (ie a trim switch pressed or switch wire is shorted to ground) during system startup, the trim circuit shows a fault. You must clear the physical fault (either a stuck switch or shorted wire), then cycle power to the system to clear the fault in the system.

##### ***10.6b Runaway trim and flaps***

Runaway trim or flaps is indicated by both switch inputs being active at the same time. This can be caused by a stuck switch, a shorted wire, or various other causes.

If you discover the trim or flaps running un-commanded, push and hold the opposite button to immediately stop the motor. The input switch pairs are as follows:

Pitch trim:	up	down
Roll trim:	left	right
Flaps:	up	down

After 3 seconds, the affected circuit faults and you can release the button. A faulted circuit does the following:

- The input switches for the faulted axis are disabled
- An alarm message is shown on the screen
- The EFIS may display soft keys that allow you to run the trim from the display.

For example, if the pitch trim begins to “run away,” hold down the opposite pitch trim switch (a natural reaction, by the way) until the fault shows on the screen. When it does, the switches are disabled.

After a runaway condition, you can re-enable the trim or flap circuit by selecting it from the list of items on the EFIS electrical page and press the “Re-Enable” soft key. You cannot re-enable the trim or flaps if a switch input is active.

#### ***10.6c Trim and flap operation with a faulty position sensor***

The position feedback is ignored when the trim and flaps are operated using the soft keys on the EFIS. When you select the Flaps from the electrical system page, the EFIS displays the Flap Up and Flap Down soft keys. The display is similar when the Trim is selected. This allows you to run the trim and flaps if a position sensor is showing faulty readings.

#### ***10.6d Max Flap Speed Functions***

The VP-X can alarm or limit flap functions based on indicated airspeed provided by the EFIS. The following functions are supported, and configurable in the setup menus:

- **Flap over-speed alarm.** When the flaps are extended beyond the specified limit and the indicated airspeed is above the specified max flap speed, then the an alarm is displayed on the EFIS.
- **Disable flaps above max flap speed.** The flap down switch is disabled above the specified max flap speed. You can raise the flaps but not lower the flaps.

The flap disable function is ignored when the flaps are operated from the EFIS.

### **10.7 Landing Light Wig-Wag**

If enabled, the forward lights (landing and/or taxi) can be configured to wig-wag (pulse) when turned on. The wig-wag system incorporates the following features:

- a) Pulsing starts automatically above a specified airspeed, so the lights are steady on the ground but pulsing in the air for increased visibility.
- b) Warm-up before pulsing. The lights will remain on steady for the specified period of time before pulsing begins. There is a minimum five-second warm-up period to allow the system to detect any circuit faults.
- c) Pulsing can be manually stopped by pressing WIG-WAG STEADY soft key on the EFIS. Press WIG-WAG AUTO to set back to automatic control. Consult the EFIS manual for specific instructions.

## 10.8 Circuit Faults

A circuit fault can be caused by the following conditions:

1. Short circuit: the wire is grounded, either momentarily or permanently
2. Over-current: the electrical load exceeds the circuit breaker value
3. Current fault: the device is drawing no current for three seconds when turned on. This is user-configurable on all circuits except trim, flaps, and starter.

When a fault occurs, the VP-X turns off the circuit. It remains OFF until the fault is manually reset using the EFIS screen. Consult the EFIS manual for specific instructions related to clearing the fault.

## 10.9 Starter Disable

The starter circuit is normally on, meaning the starter switch has power at all times when the engine is not running.

The starter circuit is automatically turned OFF whenever the engine RPM is valid and is above 500 RPM. You cannot manually turn the starter circuit on and off.

## 10.10 Low-Voltage Alarm

A low voltage condition is detected and reported by the EFIS.

## 10.11 Over-Voltage Alarm

The VP-X detects an over-voltage condition, which generally occurs because either the voltage regulator or alternator has failed in a manner that allows the alternator to produce higher voltage levels than normal.

When an over-voltage condition is detected, the active alternator (either the primary or backup) is turned OFF and an alarm is displayed on the EFIS screen.

You can reset the faulted alternator circuit in the same way you reset any other faulted circuit. The alternator switch cannot turn the alternator back on until the fault is cleared.

Because the alternator circuit is disconnected, you will shortly get a low-voltage alarm. When this happens you can switch to the backup alternator.

## 10.12 Battery Contactor Failure

If the battery contactor fails, power is lost to the main bus and therefore the VP-X. Turn on the backup circuits to operate critical avionics.

## 10.13 Backup Circuits

The VP-X allows an unlimited number of backup circuits. Each backup circuit is wired directly to the battery bus through a separate and independent fuse and switch. If a backup switch is turned off, the VP-X controls power to the device. Turning on a backup switch powers the device independently of the VP-X.

Select and use the backup capability intelligently. For example, if your attitude reference is one of the backup circuits, you can turn on its backup power when flying in reduced visibility (IMC and/or night) and then have an electrical malfunction and the reference stays powered. Note that certain failure modes exist that, although rare, can fault the entire electrical system – including the backup circuits.

Care in the construction and maintenance of your electrical system is the best way to mitigate these risks.

The backup switches provide power to their respective devices even after the VP-X shuts off. Remember to turn off backup power after it is no longer needed.

#### **10.14 Data Comm Loss**

If the data bus between the VP-X and the EFIS fails, the VP-X will continue to operate normally and provide circuit protection. However, any data normally displayed by the EFIS is no longer available. This includes fault display, circuit status, configuration, software updates, and the ability to reset faults.

Additionally, because the EFIS is no longer providing data to the VP-X, the following functions are disabled:

- landing light wig-wag will reset to steady operation
- variable speed pitch trim will reset to normal speed operation
- flap over-speed functions are disabled

#### **10.15 Software Updates**

Software updates are “pushed” to the VP-X by the EFIS. Software updates are available on the VP web site under support, then go to software upgrades. The VP-X settings are kept intact during the software upgrade. **DO NOT CYCLE POWER TO THE VP-X DURING A SOFTWARE UPGRADE.**

To upgrade VP-X using **GRT HX**:

1. Store the file **cu.hex** (from the VP web site) on a USB flash drive and insert into the USB port on the HX display connected to the VP-X.
2. Select Set Menu to go into the setup menus.
3. Select Display Unit Maintenance -> VP-X Configuration.
4. Select Update VP-X software.

To upgrade VP-X using **MGL**:

To upgrade VP-X using **AFS**:

## 11 Appendix A – Pinout Diagram

System Name	Amps Range	Physical Pin	I/O
Flap	1-10	J3-1/2	O
Starter	1-10	J3-4	O
EFIS	1-5	J3-6	O
Field_Pri	1-5	J3-5	O
5A-1	1-5	J3-7	O
5A-2	1-5	J4-8	O
5A-3	1-5	J4-9	O
5A-4	1-5	J4-10	O
5A-5	1-5	J5-3	O
5A-6	1-5	J5-4	O
5A-7	1-5	J6-9	O
5A-8	1-5	J6-10	O
5A-9	1-5	J6-11	O
5A-10	1-5	J6-12	O
5A-11	1-5	J6-13	O
5A-12	1-5	J6-14	O
5A-13	1-5	J6-15	O
10A-1	1-10	J4-3	O
10A-2	1-10	J4-4	O
10A-3	1-10	J4-5	O
10A-4	1-10	J6-1	O
10A-5	1-10	J6-2	O
10A-6	1-10	J6-3	O
15A-1	1-15	J6-4	O
15A-2	1-15	J6-5	O
15A-3	1-15	J6-6	O
3A-1	1-3	J4-7	O
2A-1	1-2	J7-8	O
2A-2	1-2	J7-9	O
Trim Roll	2	J7-22/23	O
Trim Pitch	2	J7-6/7	O
S1		J7-11	I
S2		J7-12	I
S3		J7-21	I
S4		J7-27	I
S5		J7-30	I
S6		J7-33	I
S7		J7-34	I
S8		J7-35	I
S9		J7-36	I
S10		J7-37	I

### Other I/O

Function	Pin	I/O
Aux batt voltage	J5-11	I
Starter annunciator input	J5-12	I
Roll trim position	J7-5	I
Pitch trim position	J7-26	I
Serial TX	J7-1	O
Serial RX	J7-20	I
Flap Up	J7-14	I
Flap Dn	J7-15	I
Roll Trim L	J7-16	I
Roll Trim R	J7-17	I
Pitch Trim U	J7-18	I
Pitch Trim D	J7-19	I

## 12 Appendix B – Wiring Harness Contents

The following wire types and lengths are included in the wiring harness kit:

Qty	Gauge	Length (ft)	Color	Terminal on one end
1	20	50	wht	none
1	22	50	wht	none
1	14	10	black	none
1	18	20	black	none
1	20	40	black	none
3	14	20	wht	female power connector
8	18	10	wht	female power connector
2	18	15	wht	female power connector
11	20	5	wht	female power connector
6	20	20	wht	female power connector
2	20	5	wht	male power connector (test leads)
1	24T 3C Sh	20	wht	Data line to EFIS and flap position sensor
1	24T 5C	35	wht	Pitch and roll trim cable

The following items are also included:

Qty	Item
1	8 pin power connector
1	10 pin power connector
1	12 pin power connector
1	16 pin power connector
1	37 pin male dsub connector
1	37 pin dsub connector hood with thumbscrews
40	Male dsub pins
1	Rubber boot
1	Pin removal tool (removes pins from power connectors)
1	Diode for battery contactor
2	1K resistor for aux battery voltage and starter annunciator inputs

### 13 Appendix C - VP-X System Annunciators

The following VP-X annunciators are displayed on the EFIS:

Alarm	Description
TRIM RUNAWAY	The trim switches are disabled because opposite trim switches were active for at least 3 seconds. The fault can be cleared from the EFIS. If it won't clear, a trim switch is still active.
TRIM DISABLE	The VP-X was powered on while a trim switch is active, disabling all of the trim switches. You must repair the trim switch problem and cycle system power to restore functionality (to discourage flight with a faulted trim system). Trim can be operated via the EFIS.
TRIM SWITCH ACTIVE	A runaway trim condition is not able to be cleared because a trim switch input is still active. The system will not re-enable the trim switches while a trim switch input is active. Trim can be operated via the EFIS.
FLAP RUNAWAY	The flap switches are disabled because both the flap up and flap down switches were active for at least 3 seconds. The fault can be cleared from the EFIS. If it won't clear, a flap switch is still active.
FLAP DISABLE	The VP-X was powered on while a flap switch is active, disabling the flap switch. You must repair the flap switch problem and cycle system power to restore functionality (to discourage flight with a faulted flap system). Flaps can be operated via the EFIS.
FLAP SWITCH ACTIVE	A runaway flap condition is not able to be cleared because a flap switch input is still active. The system will not re-enable the flap switch while a flap switch input is active. Flaps can be operated via the EFIS.
FLAP OVERSPEED	The flaps are extended above the specified airspeed.
STARTER	The starter contactor is closed.
WIG-WAG	The landing lights are on and either warming up or pulsing (wig wag).
VP-X DATA FAULT	The VP-X has failed internal data integrity checks. The system resets to its default values and the EFIS turns on to display the specific fault. The switch settings, trim and flaps settings are cleared and do not operate. The EFIS may be able to restore the settings to the VP-X. Flight is not recommended until the VP-X is re-configured.
OVER-VOLTAGE	An overvoltage condition occurred and the alternator field was faulted to clear the condition.
VP-X NO EFIS DATA	The VP-X is not receiving data from the EFIS.
VP-X COMM LOSS	The EFIS is not receiving data from the VP-X. The VP-X will continue to operate normally and provide circuit protection. However, any data normally displayed by the EFIS is no longer available.
VP-X HIGH CURRENT	The VP-X is operating near its maximum current limits. Turn off devices to reduce current.
VP-X MAX CURRENT	The VP-X is operating over its maximum current limits. Turn off devices to reduce current.
Short Circuit Over Current Current Fault Over-Voltage	Fault is displayed on the electrical system page in association with the faulted circuit.
VP-X RESET	The VP-X performed an internal reset. Verify normal operation of system. Cycle power to reset. Report the problem to tech support if this happens on a frequent basis.
Wig-Wag Config	A pin used for wig wag cannot be set to switch 0 (always off), 11 (always on) or as the secondary alternator.

## 14 Appendix D – MGL to PC Interface Cable

### VP-X to MGL EFIS serial connection.

1. The VP-X, when used with MGL, is configured using the VP-X Configurator application running on a Windows PC.
2. For VP-X only, not for VP-X Pro or Sport.

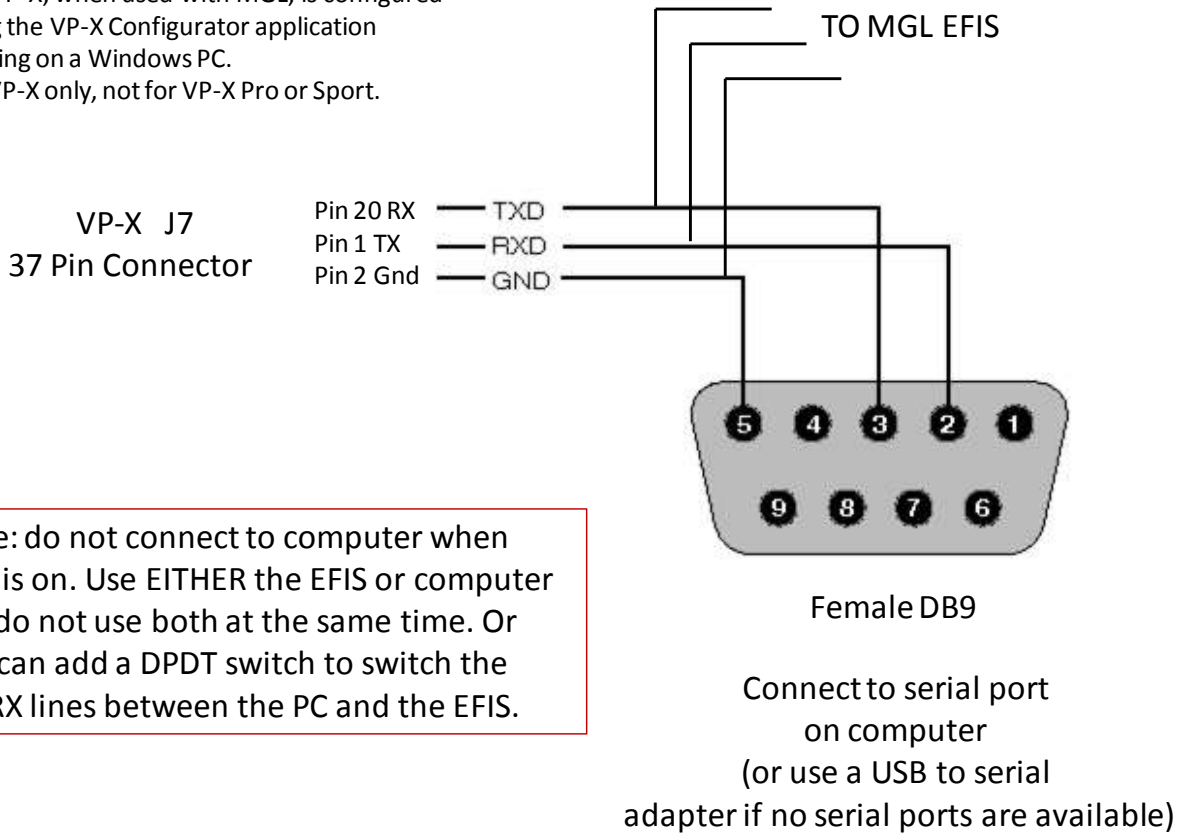

Rev A