

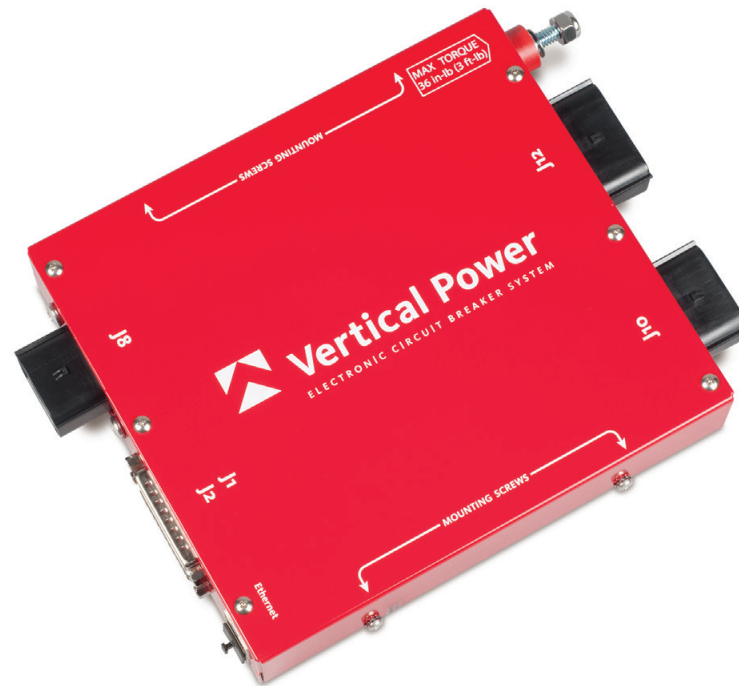

Electronic Circuit Breaker System VP-X Pro — VP-X Sport



Installation and Operating Manual

May 23, 2023
Rev. G4

Current as of software version 1.6

Important Notice

This manual contains important information that may affect the safety of your aircraft. Do not fly the aircraft until you fully understand the installation and operating instructions, and all of the pre-flight checks have been successfully completed.

Read the Limited Warranty document (Limited Warranty - Vertical Power Products) available at www.verticalpower.com. There is information in the Limited Warranty that may alter your decision to install this product. **If you do not accept the terms of the Limited Warranty, do not install this product.** The product may be returned for a refund if you do not accept the terms of the Limited Warranty.

Astronics is not liable or responsible for a pilot's action or any situation that results in personal injury, property damage, missed commitments, lack of use of an aircraft or any expenses incurred due to: product failure, inaccuracy in displayed data or text files, display or display format issues, software bugs or problems, upgrade or customization issues, misinterpretation of the display, warning and/or limit settings, calibration problems, installation issues (leaks, mis-wiring, obstructions, damage to aircraft or components, incorrect installation of any parts, wrong parts, parts that don't fit, etc.) or any other issues related to the installation or operation of this product. All of the above are solely the pilot's and/or installer's responsibility.

The pilot must understand the operation of this product before flying the aircraft. The pilot will not allow anyone to operate the aircraft that does not know the operation of this product. The pilot will keep these Operating Instructions in the aircraft at all times. The ability for this product to correctly control electronic components and detect a problem is directly related to the pilot's ability to properly install the system, and the pilot's interpretation and observation skills.

By installing this product, the aircraft owner/pilot and installer agree to hold Astronics harmless and in no way responsible for monetary compensation, including punitive damages for any incident, harm and/or damage associated with this product (including but not limited to the ones listed above). If you do not agree to the above, **DO NOT INSTALL THIS PRODUCT.** The pilot, aircraft owner and/or installer may want to obtain an appropriate insurance policy before installing this product. If you do not have the skills, knowledge, tools, equipment or facility, to perform and determine the installation of this product is safe, reliable and accurate and to determine this product is operating properly after installation, **DO NOT INSTALL THIS PRODUCT.** If the aircraft owner/pilot and/or installer are unwilling to take the responsibility for the installation and operation of this product, **DO NOT INSTALL THIS PRODUCT.** This product may be returned for a refund by contacting Astronics.

It is possible for any system to fail thereby disabling electronic components or displaying inaccurate high, low or jumpy readings. Therefore, you must be able to recognize a system failure and you must be proficient in operating your aircraft safely in spite of a system failure. **IT IS THE BUILDER AND/OR PILOT'S RESPONSIBILITY**

TO DETERMINE THE APPROPRIATE LEVEL OF BACKUP AND REDUNDANT SYSTEMS NEEDED FOR SAFE OPERATION OF THE AIRCRAFT. If you do not have this knowledge or skill, contact the FAA, a certified aircraft mechanic, or a local flight instructor for training prior to building or flying the aircraft with this system. Before flying the aircraft verify the instrument markings displayed on the system are accurate with your POH for every function displayed. Verify that each electrical device is configured correctly and behaves appropriately. All data must be verified by the pilot before it is used.

Before starting the installation, make sure that your planned installation will not interfere with the proper operation of any controls. The installer should use current aircraft standards and practices to install this product. Refer to AC 43.13-2A, Acceptable Methods, Techniques, and Practices - Aircraft Alterations and AC 43.13-1B, Acceptable Methods, Techniques, and Practices—Aircraft Inspection and Repair.

This is an experimental system limited to use in experimental aircraft or Light Sport Aircraft. These products are not approved for use in aircraft with FAA or foreign type certificates.

Limited Warranty

For warranty information, please refer to the Limited Warranty document (Limited Warranty - Vertical Power Products) available at www.verticalpower.com.

Copyright Notice

Copyright ©2023 by Astronics. Astronics' permission to copy and distribute this manual is for the purchaser's private use only and is conditioned upon purchaser's use and application with the hardware that was shipped with this manual. No commercial resale or outside distribution rights are allowed by this notice. This material remains the property of Astronics. All other rights reserved by Astronics.

Trademarks

Vertical Power is a registered trademark of Astronics. All other product names or trademarks are property of their respective owners.

Astronics

The home of Vertical Power products

12950 Willows Road NE

Kirkland, WA 98034

Phone: +1.425.328.1658

Email: info@verticalpower.com

Table of Contents

1. Introduction

1.1 Welcome to Vertical Power!	7
1.2 Vertical Power Terms	7
1.3 Other Reference Documents	8

2. VP-X Overview

2.1 Installation Overview	9
2.2 System Overview	9
2.3 Supported Bus Architecture	9

3. Electrical System Basics

3.1 Free Advice on Designing your Electrical System	10
3.2 Introduction	11
3.3 Alternator Operation	11
3.4 Wire Sizes and Circuit Protection	11
3.5 Grounding	12
3.6 Switch Nomenclature	12
3.7 Alternator Current Sensing (Shunt)	13
3.8 Bench Testing the VP-X	13

4. Planning

4.1 EFIS	14
4.2 How Switches Are Wired	14
4.3 Wiring Harness	15
4.4 Dual Bank Technology (VP-X Pro)	15
4.5 Tools and Other Stuff	17
4.6 VP-X Connectors	17
4.7 Installing and Removing Power Connector Terminals	18
4.7a Installing terminals	18
4.7b Removing terminals	19
4.7c Pin Removal Tool	20
4.8 Alternator and Voltage Regulator Considerations	20
4.8a Over-voltage Planning	21
4.8b Low-voltage Planning	21

4.9 Landing Light Wig-Wag (Pulsing) Considerations	21
4.10 HID Light Considerations	21
4.11 Electronic Ignition Considerations	21
4.12 Electric Motor Considerations	22
4.13 VP-X Planner	22
4.13a What if I run out of power pins?	23
4.13b What if I run out of switch inputs?	23

5. Installation

5.1 Pre-Installation Tasks	24
5.2 VP-X Installation	24
5.3 Wiring Harness Construction	26
5.4 Backbone Wiring	26
5.5 Master Contactor Wiring	27
5.6 Starter Switch and Contactor Wiring	28
5.7 Starter Annunciator Wiring	29
5.8 Other Contactor Wiring	29
5.9 Alternator Wiring	30
5.9a Primary Alternator (B&C External Regulator)	30
5.9b Primary Alternator (Plane Power)	31
5.9c Backup Alternator (B&C 20 Amp)	32
5.9d Backup Alternator (B&C 8 Amp)	32
5.9e Backup Alternator (Plane Power 30 Amp)	33
5.9f Alternator – Rotax or Jabiru engines	33
5.10 Primary EFIS Wiring – Power and Data Connections	34
5.11 Advanced Flight Systems EFIS Wiring	35
5.12 GRT EFIS Wiring	35
5.13 MGL EFIS Wiring	35
5.14 Garmin G3X Wiring	35
5.15 Dynon SkyView Wiring	35
5.16 Items you don't have to wire to the EFIS	36
5.17 Ground Wiring	36
5.18 General Power Wiring	37

Contents (Continued)

5.19 Trim System Wiring	37	5.28 AeroLEDs Wiring	52
5.19a Pitch Trim Wiring	38	5.29 Strobe Light (non-LED) Wiring	53
5.19b Roll Trim Wiring	39	5.30 Retractable Gear Wiring	53
5.19c TruTrak Auto Trim Module	39	5.31 Testing Individual Circuits	53
5.19d Co-Pilot Disconnect Switch	39		
5.19e Wiring a third trim motor	39	6. Configure the System Settings	
5.19f PH Aviation Trim	40	6.1 Configuring the AFS EFIS	55
5.19g Garmin GSA 28 With Auto-Trim	40	6.2 Configuring the GRT EFIS	55
5.19h Trio Auto Trim Module	40	6.3 Configuring the MGL EFIS	55
5.20 Flap System Wiring	40	6.4 Configuring the Garmin G3X EFIS	56
5.20a Flaps System With Limit Switches	42	6.5 Configuring the Dynon SkyView	56
5.21 Panel Switches Wiring	42	6.6 Installing and using the VP-X Configurator	56
5.21a Standard switches	42	6.7 Switch Input Verification	56
5.21b Wiring lighted switches	43	6.8 Device Configuration (Starter, Avionics, Lights, etc.)	57
5.21c Alternator switch	43	6.9 Current Fault Detection	57
5.21d Boost pump switch	44	6.10 System Configuration (Over-voltage and Backup Alternator)	57
5.21e Dual-Function Switch	44	6.11 Wig-Wag Configuration	58
5.21f Dimmer wiring	44	6.12 Trim Configuration	58
5.21g Mag switch wiring	45	6.13 Flaps Configuration	59
5.22 P-Mag wiring	45	6.14 Export Settings	62
5.23 Lightspeed Ignition wiring	45	6.15 Import Settings	62
5.24 Planning and Wiring Backup Circuits	46	7. Ground Test	
5.24a Backup Circuit Considerations	46	7.1 Testing without engine running	63
5.24b Backup Method B	47	7.2 Testing while engine running	63
5.24c Backup Method C	48	8. Flight Test	
5.24d Do not wire backups this way	48	8.1 Notes about first flight	64
5.24e Aft-mounted battery considerations	49	8.2 VP-X system checkout	64
5.25 TCW Integrated Back-Up Battery System	49	9. Troubleshooting	
5.25a TCW IBBS 2/4ah Wiring	49	9.1 Flap Configuration	65
5.25b TCW IBBS 3/6ah Wiring	50	9.2 Electrical Configuration	67
5.26 Dual Battery/Single Bus Wiring	51	9.3 Trim faults	67
5.27 Aux Battery Wiring and Voltage Measurement	52	9.4 “Cannot Connect” error when using VP-X Configurator	67

Contents (Continued)

10. VP-X System Operation

10.1 Power On and Off	68
10.2 EFIS Electrical System Page.	68
10.3 Other VP-X functions.	68
10.4 Turning electrical devices on and off	68
10.5 Trim and flap operation	68
10.5a Trim switch fault detection on startup	69
10.5b Runaway trim and flaps.	69
10.5c Trim and flap operation with a faulty position sensor	69
10.5d Max Flap Speed Functions	69
10.5e RV-10/RV-14 Flap Reflex Operation	69
10.5f Continuous Flaps	70
10.6 Landing Light Wig-Wag	70
10.7 Circuit Faults	70
10.8 Starter Disable	70
10.9 Low-Voltage Alarm.	70
10.10 Over-Voltage Alarm	70
10.11 Battery Contactor Failure.	70
10.12 Backup Circuits	70
10.13 Data Comm Loss.	71
10.14 Firmware Updates	71

Appendix

Appendix A – Pinout Diagram	72
Appendix A1 – J8, J10, J12 Connector Wiring	73
Appendix A2 – J1 Connector Wiring	74
Appendix A3 – J2 Connector Wiring	75
Appendix B – Wiring Harness Contents	76
Appendix C – VP-X System Annunciators	77
Appendix D – VP-X Dimensions and Weight	78
Appendix E – AeroLED Wiring Tips.	79
Appendix F – Ray Allen Stick Grip Wiring	80

Change Log

Change Date	Revision	Change
Aug 26, 2010		Initial public release
Oct 27, 2011		Added Rotax and Jabiru alternator section.
Nov 3, 2011		Added dimension drawings to Appendix.
Dec 13, 2011		Added pinout diagrams in Appendix.
Feb 6, 2012		Added more detail on EFIS data wiring. Added strobe and AeroLED diagrams.
Feb 20, 2012		Fixed label on Option 2 dual battery diagram.
May 16, 2012		Added clarification about connecting serial data line to GRT EFIS.
July 12, 2012		Updated dual battery drawings: moved contactor diode placement.
Aug 20, 2012		Updated flap troubleshooting section. Updated DualBuss Technology section.
Dec 1, 2012		Added RV-10 flap reflex and continuous flaps features. Primary alternator disable feature. 1.4 firmware update.
Feb 27, 2012		Added Eagle EMS and updated IBBS section.
May 3, 2013		Added GSA 28, minor corrections.
May 15, 2013		Added section on advice for planning electrical system.
June 24, 2013		Added guidance for HID lights.
July 24, 2013		Added note about flap circuit breaker value and newer VP-X.
Sept 25, 2013		Added second option for wiring starter annunciator.
Sept 26, 2013		Added more alternator switch wiring options.
Nov 22, 2013		Added section on dual-function switches.
Aug 28, 2014	B	Added Trio Auto Trim, moved warranty to separate document, updated style, minor corrections.
May 18, 2017	C	Added additional info about the TCW IBBS. Phantom voltage info. Updated Installing Terminals images. Removed Subaru and Viking engine appendices.

Change Date	Revision	Change
Aug 5, 2020	D	General manual update with multiple corrections and additions. Added references to the Vertical Power PPS.
Feb 1, 2021	E	Added PPS wiring instructions for primary and backup alternator using the LR3C external voltage regulator in Section 5.9a and 5.9c.
Jan 12, 2022	F	Updated wiring color code for the Ray Allen trim servo, trim position sensor, and flap position sensor. Added references to B&C LR3D voltage regulator.
April 5, 2022	G	Updated wiring for LR3C/LR3D Vsense line for proper connection to the PPS.
April 6, 2022	G1	Updated wiring table in Section 5.9c.
Oct 10, 2022	G2	Added power lug drag torque warning to Section 5.5; clarified SPST switch instructions in Section 5.24c.
Dec 7, 2022	G3	Updated pin numbers in Trio Auto Trim Module diagram in Section 5.19h
May 23, 2023	G4	Clarified wire size for starter switch wiring with the PPS in Section 5.6. Added reference to Ray Allen servos B6-7T and B6-11T in Section 5.19; added details for Van's Aircraft PA-12 flap motor in Section 5.20. Corrected flaps max run time in Section 9.1.

1. Introduction

1.1 Welcome to Vertical Power!

The VP-X is an innovative way to intelligently control the electrical devices on your aircraft using electronic circuit breakers (ECBs). The VP-X family includes the VP-X Pro and the VP-X Sport models. This manual covers both products. The physical installation for both products is identical, and setup is nearly identical (the difference being that the VP-X Sport has eight fewer circuits).

While the VP-X makes life a lot easier for the builder, it's not simply a plug-and-play solution. The builder must still run wires to electrically-powered components and this wiring takes some careful planning. Please take the time to read and understand this manual before proceeding.

This manual describes the installation steps and techniques necessary to install the VP-X. It is also intended to provide the information you need to know to capably wire your electrical system. Because many of the features are controlled using the setup menus rather than with hard-wired components, you can easily change things in the future.

This manual is updated as required, so check the Vertical Power web site for updates during your build.

If you follow each of the five steps outlined in this manual, you will have a safe and full-featured electrical system.

1.2 Vertical Power Terms

VP-X	VP-X is used by itself when the topic covers both the Pro and Sport models. When the topic covers only a specific product, then either "VP-X Pro" or "VP-X Sport" is used.
PPS	The Vertical Power Primary Power System (PPS) is a solid-state device that handles high-current primary power, replacing electro-mechanical components.
Device	A user of electrical power. It may be a light, radio, GPS receiver, contactor, or EFIS, just to name a few. A device is wired to a power pin on the VP-X.
Pin	A pin refers to a physical pin on one of the VP-X connectors that provides power to a device. Special-purpose pins are provided for flaps, trim, starter, and EFIS. Most pins, however, are generic and can be configured to match the type of load it is powering. Each pin has a maximum current rating up to 15 amps.

State	There are three states: on, off, or faulted. Faulted is equivalent of a tripped circuit breaker.
Connector	Two types of connectors are used throughout the system. D-sub connectors are smaller and provide signal and low power (less than 2 amps) connections. The VP-X incorporates high quality, gold plated, machined-barrel connectors. High-quality, Molex gold-plated connectors are used to provide power (up to 15 amps) to high current devices.
AWG	American Wire Gauge – a standard that describes the size of the wire.
Circuit breaker	While the VP-X does not use conventional circuit breakers or fuses, the term is very common and herein is used to mean the maximum current a circuit will draw before faulting.
Fault	The VP-X protects each circuit from short circuits, over-current conditions, and current fault (open circuit) faults. When a fault occurs, the VP-X turns the faulted device off, and the EFIS displays an alarm message. You can then reset or clear the fault from the EFIS screen, similar to resetting a circuit breaker.
Backup circuit	A backup circuit allows you to power a device directly from the battery through an external switch (separate from the VP-X). When the external switch is turned on, fused power is provided directly from the battery to the device regardless of whether or not the battery contactor is closed or the VP-X is turned on. Wiring these circuits is optional.
B-lead	This is the large wire that goes from the alternator to the main electrical bus. It provides current from the alternator to the battery and electrical bus.
p-lead	This is the wire that goes from the mag switch to the magneto. There is a p-lead for each magneto.

1.3 Other Reference Documents

We provide other documents that should be used in conjunction with this manual to help you thoroughly plan a safe and effective electrical system for the type of mission you fly. The following documents are available on the Documentation page of the Vertical Power web site (www.VerticalPower.com), and should be reviewed in conjunction with planning your electrical system.

Document	Description
Contactor Wiring	Overview of the different types of contactors used in experimental aircraft, and step by step instructions how to wire them properly.
Device Amps	This document lists the electrical current draw of many popular radios, GPS moving maps, EFIS displays, lights, and other avionics. We maintain it, but contributions come from builders.
Top 10 Wiring Mistakes	A free, 12-page paper describing the most common wiring mistakes and how to get started wiring your aircraft.

Additional documentation may also be available on the web site.

2. VP-X Overview

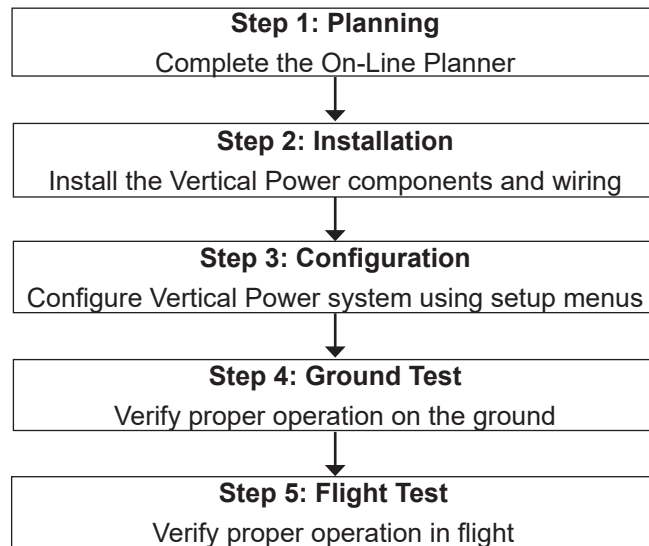

2.1 Installation Overview

The installation of the VP-X is accomplished in five main steps, and the amount of work for each step is shown by the relative size of the boxes shown above.

Following these steps will increase the likelihood of a trouble-free electrical system. Each step is described in detail later in this manual. You can optionally swap steps 2 and 3 and set everything up on the bench first.

We recommend that you read through all five steps so that you better understand the system prior to beginning the planning step.

Taking the time up front to carefully plan your electrical system will pay big dividends later on.

2.2 System Overview

The VP-X provides circuit protection, circuit switching, trim and flap control, and a host of other functions. The electrical devices are controlled by conventional switches that are wired into the VP-X. The VP-X integrates with popular EFIS units, which display electrical system information. Trim and flap position information from the VP-X is also displayed on the EFIS, and circuit faults can be reset from the EFIS.

The VP-X system architecture with the PPS is shown below:

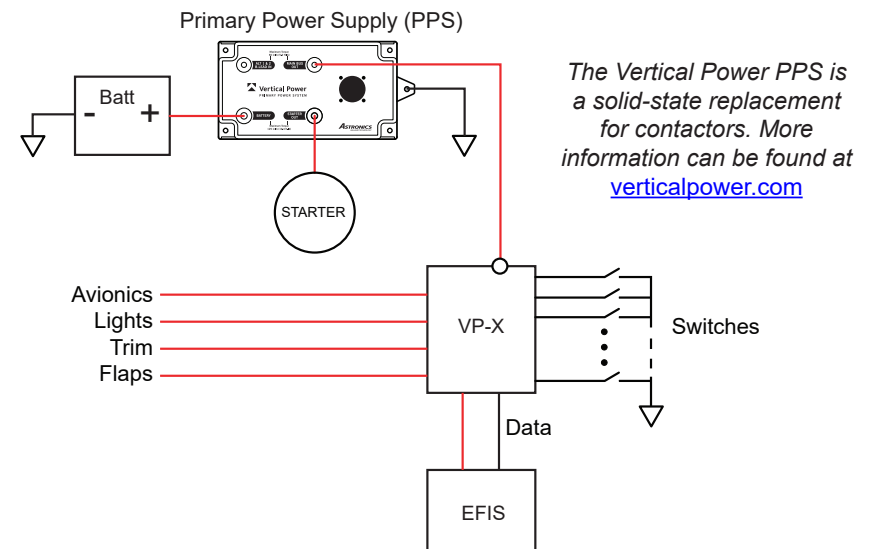

The VP-X system architecture in a conventional system is shown below:

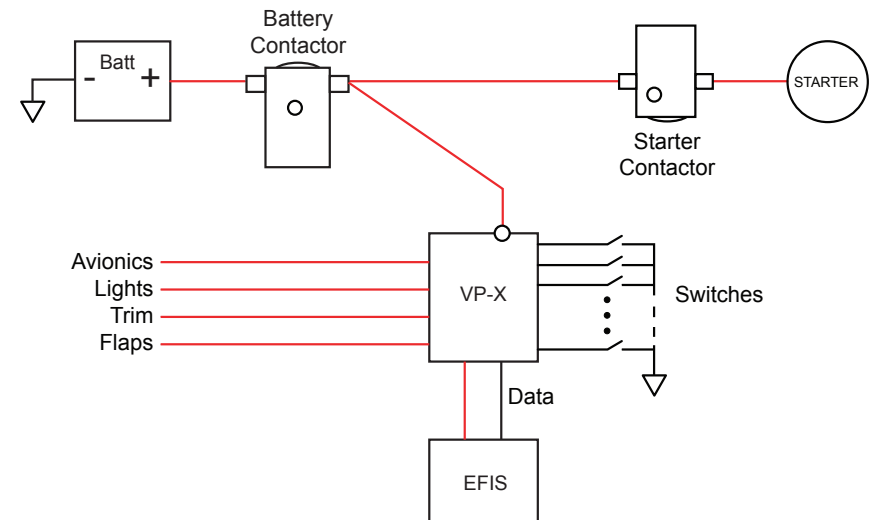

2.3 Supported Bus Architecture

The VP-X supports a single main aircraft electrical bus architecture, with one or two alternators and one or two batteries. An additional independent backup or 'e-bus' can be added as well for redundancy (described later in this manual).

3. Electrical System Basics

This manual and the accompanying documentation on the Vertical Power web site are intended to provide enough detail to understand overall concepts and safely wire your aircraft. Should you want more information, additional resources can be found in a variety of books and texts, a few of which are shown here:

- FAA Advisory Circular AC 43.13, *Acceptable Methods, Techniques, and Practices - Aircraft Inspection and Repair* available from www.faa.gov
- FAA Advisory Circular AC 23.1311, *Installation of Electronic Display in Part 23 Airplanes*, available from www.faa.gov
- *EAA Hints for Homebuilders* <https://www.eaa.org/Videos/Hints-for-Homebuilders>
- AeroElectric Connection book, available from www.aeroelectric.com
- https://www.eaa.org/shop/SAW/SportAir_Workshops.aspx
- Aircraft Wiring Guide, by Mark Ausman, more info at <https://www.aircraftwiringguide.com/>

3.1 Free Advice on Designing your Electrical System

Many builders are new to electrical wiring and find it daunting. Even experienced electrical engineers may not be familiar with good practices specific to aircraft wiring. With that in mind, we've added lots of detail throughout this manual. Before we dig into those details, this section will help you to think about the big picture as you design your electrical system.

When designing your electrical system, there is a temptation to copy or do things the same way as your buddy did them when he built his plane. Avoid that temptation. Every experimental aircraft is different and is used in different ways. It may end up that your plane, when finished, is similar in certain ways to your friend's plane, but that should be because your requirements are similar and not because you blindly copied him.

We believe the most important free advice we can offer is the following:

CLARIFY YOUR MISSION

In this age of gadgets, it is all too tempting to add just one more enhancement, then one more again, until we lose sight of how and why we are building an airplane in the first place. Think about the most basic things first. What will your plane be used for? What type of weather will you be flying in? What do the worst-case scenarios look like?

The outcome of this decision drives not only how you wire your electrical system, but also what avionics and other equipment you put in the aircraft.

If you clarify your mission like this, determining not only what it is but just as importantly what it isn't, you will be ready to adopt our next bit of free advice:

COMMIT YOUR ELECTRICAL SYSTEM TO PAPER

It is surprising to us how many builders, after relying on many pages of detailed plans for their airframes, use little more than a napkin or a single sheet of copy paper to draw out their electrical system. Planning and researching your design and then committing every detail of that design to hardcopy before you buy equipment and run wires will pay huge dividends later on.

Whether you're comfortable with either a pencil or a keyboard, write and draw everything down, somewhere. Use whatever tools work best for you — paper, PowerPoint, AutoCAD, or spreadsheets. We cannot design your electrical system for you, but we can be a valuable sounding-board for your thoughts. We even have an on-line planning tool at planner.verticalpower.com that is a big step in the forward direction. After helping many different customers with many different designs, we've learned that it's much easier to erase than to rewire. Much cheaper too.

While you commit your design to paper, erasing and redrawing as many times as it takes to get it right, please keep in mind our last piece of free advice:

KEEP IT SIMPLE

As a basic rule, the more complex something is the more likely it is to break. For some reason, while most experimental airplanes are built as dependable but simple vehicles, their builders are enticed to attach every electrical bell and whistle they can find in a catalog. By adding more relays, busses, terminals, diodes, wires, and (let's face it) toys, you are actually adding more things that can fail and more things that make it harder to troubleshoot.

Before you delve into the details of designing your electrical system, please consider these three bits of advice. If you do so, the end result will be an electrical system and avionics package that meets your real needs when you get your project in the air.

3.2 Introduction

An aircraft electrical system can be divided into three parts:

1. “Backbone” components: aircraft battery, alternator, voltage regulator, the [Vertical Power Primary Power System](#) (PPS) and associated wiring. This is called the primary power distribution system. In place of the PPS, you can also use traditional contactors. Contactors are just high-capacity relays that are energized by low power signals but allow large amounts of power to pass through.
2. Busses, switches, smaller wiring, and circuit protection (fuses and/or circuit breakers). This is called the secondary power distribution system.
3. Users of power and the wiring to and from those users. Users may be lights, instruments, avionics, pumps, etc. The term *device* or *load* is used in this manual to generically describe all the users.

More on electrical system basics:

- The aircraft **battery** and **alternator** provide power to all electrically-dependent systems. Normally, the battery powers systems before and during starts and then the alternator takes over charging the battery and providing power to the electrical devices. The Vertical Power **Primary Power System** (PPS) connects (or disconnects) the high-current wires between the battery and the main power distribution bus. In place of the PPS, you can also use a traditional battery contactor.
- Power typically runs from the battery/alternator to **electrical busses** behind the panel where power is split and sent to individual devices through **circuit protection devices** (fuses and circuit breakers) and switches. The VP-X assumes the role of busses, circuit protection, and a host of single-function modules. During construction, the VP-X greatly simplifies the task of wiring your aircraft.
- **Wire** sizes vary and the size of the wire to each device is determined by the current load (amps) of that device as well as the distance the current must travel. If a wire is too small for the load or distance, it will heat up and possibly fail. If the wire is too big, it will certainly carry the load but at the expense of added weight.
- To complete the electrical path, devices must have a ground. This means connecting a ground wire to the metal aircraft structure or ground plane (aircraft ground) or running a ground wire from the device to a central location such as a firewall grounding point.

3.3 Alternator Operation

The alternator provides power to devices and also charges the aircraft battery. The **voltage regulator** continuously monitors the bus voltage and adjusts the output of the alternator. The regulator only works when it is powered from a bus through a wire called the **field wire**. Some alternators are internally regulated (the regulator is built in), and others have external regulators (a separate box located outside the alternator).

Today’s experimental aircraft are powered by either 14 volt or 28 volts systems. Often you may hear 12 volt or 24 volt systems. Why the difference? The reason is because the batteries are rated at either 12 or 24 volts. When the engine is running and the alternator is turned on, the alternator generates 14 volts or 28 volts, slightly higher than the battery voltage so it will keep the battery charged.

If you have a primary alternator and a secondary (backup) alternator only one alternator (field wire) should be powered on at a time. Therefore, we refer to one alternator as the primary and the other as the secondary. If both are on simultaneously, they do not equally “contribute” to powering the loads. The one whose voltage regulator is set to the highest voltage will draw all the current (sometimes called current hogging), possibly overloading the alternator.

When planning your electrical system, assume the alternator provides 80% of its rated output (in amperes), and therefore your total continuous load (don’t worry about trim or flaps or other transient loads) should not exceed 80% of rated alternator capacity.

3.4 Wire Sizes and Circuit Protection

A table below shows wires sizes versus loads for a typical homebuilt-size airplane. **The wire size can be larger than necessary but should not be smaller.**

Circuit breakers (and fuses) protect the wiring, not the device. If the breaker is too large, then the wire may overheat and fail. If too small, then the device may fault (breaker trips) because it draws too much current.

Most kit aircraft companies and avionics companies provide recommendations for sizing wires and breakers. You can use these recommendations, or you can borrow or purchase an ammeter to measure the current draw of each electrical device and then determine the sizes yourself.

When you know the current draw for each device, use the chart below to size the power wires. For simplicity, the VP-X wiring harnesses (purchased separately) use the four wire sizes in the table.

Up to (amps)	Use wire size (AWG)
5A	20
10A	18
15A	14
Data signal	22

3.5 Grounding

Many people think that the power, or positive, wire is the most important wire to provide electricity to a device. The electrical ground is just as important as electricity must flow the entire path from the power source to the device and back to the source. The ground wire must be the same wire gauge or a larger diameter (smaller gauge number) as the wire that provides power to the device, with the exception of VP-X ground wires from J12-4 and J10-9. See section 5.17 for more information..

A *ground loop* is when electricity takes two different paths, and each path has a different resistance. Ground loops are most noticeable in aircraft audio equipment, and can produce a variety of problems, most notably unwanted noise.

Grounding is as much of an art as it is a science. With that in mind, several options for grounding your system are provided below. Choose the one that best fits your needs. Keep in mind that more wiring means more weight (although likely negligible). Also, note that in all the examples below the avionics grounds are kept together.

- Option 1: Run a ground wire from each and every electrical device back to a common grounding point, typically a ground bus on the firewall.
- Option 2: Run ground wires from all the avionics to an intermediate grounding point, then run a larger wire from the local ground bus to the firewall ground. Run wires from all the other devices to the firewall ground.
- Option 3: Run the ground wires from the avionics to the firewall ground, and run the other ground wires to a local ground (a metal part of the airframe located near the device).

3.6 Switch Nomenclature

The chart below shows the most common switch types. A parenthesis () around a switch position indicates it is a momentary, spring-loaded position.

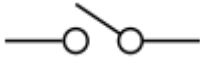
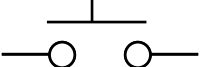
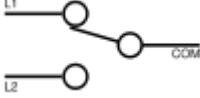
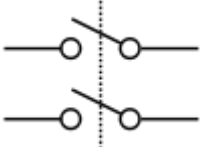
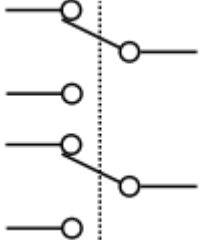
Switch Type	Design	Symbol	Mechanism
Single Pole, Single Throw	SPST		OFF-ON OFF-(ON)
			OFF-(ON)
Single Pole, Double Throw	SPDT		ON-NONE-ON ON-OFF-ON (ON)-OFF-(ON) ON-OFF-(ON)
Double Pole, Single Throw	DPST		OFF-ON OFF-(ON)
Double Pole, Double Throw	DPDT		ON-NONE-ON ON-OFF-ON (ON)-OFF-(ON) ON-OFF-(ON)

3.7 Alternator Current Sensing (Shunt)

If you are not using a Vertical Power PPS, you must consider whether to wire an ammeter (usually a shunt or hall effect sensor provided with the engine monitor) on the wire connecting the alternator(s) to the main bus. The ammeters indicate the amount of current the alternator is providing.

A shunt is not required to tell if the alternator is working. It is very easy to tell if the alternator is working correctly by simply looking at voltage. If you see 14 (or so) volts with the engine running then it is working. If you see 12 (or so) volts it is not working or not turned on or the devices are drawing more current than the alternator can provide (note, engine must be running). If you set your low voltage alarm on the EFIS at 13 volts, then you will get a low voltage alarm if the alternator fails.

Since the VP-X provides basically the same information as a shunt installed on the alternator b-lead, our position is that adding a shunt gives you no additional meaningful information.

A shunt on the alternator b-lead shows the amount of current the alternator is providing to power the devices and charge the battery. The VP-X total current reading shows the total amount of current the devices attached to the VP-X are using. The delta between the two is the battery charging current, which goes to (basically) zero after re-charging any loss from starting the engine or charging a run-down battery.

If the battery charging current is important to you, then you should install a shunt. If not, then simplify your wiring and don't install it. Your call. And of course each builder's needs are different so there is no absolutely right answer.

The EFIS displays a VP-X page which shows individual device current as well as total current through the VP-X. The EFIS also has an 'Amps' gauge that is used to show the readings from the shunt. In some cases the EFIS 'Amps' gauge can be used to display total system current from the VP-X. Please check with your EFIS manufacturer for details.

If you don't install the shunt then the shunt wires on the engine monitor/EFIS are not used.

3.8 Bench Testing the VP-X

To test on the bench, connect the VP-X to a power supply and connect either J10-9 or J12-4 to ground. Be aware that short circuit protection may not work properly in this case. You must have the VP-X connected to a battery with at least 8 AWG wire and good solid connectors.

4. Planning

It is a good idea to spend time on the planning stage whether you are installing a simple or a complex aircraft electrical system. This section discusses many items and considerations that should be incorporated into your planning. At the end of the section, you will use the Vertical Power Online Planner tool to document the design of your electrical system.

4.1 EFIS

We recommend purchasing the EFIS with its backup battery option. This way, if there is a fault on the power circuit to the EFIS, the EFIS can still communicate with the VP-X and reset the circuit breaker. Further, the battery backup keeps the EFIS from rebooting during engine start.

4.2 How Switches Are Wired

Switches are wired a bit differently on the VP-X than they are using traditional wiring. The main difference is that the switch does not carry the current of the device or devices that are being switched. This means longer life for the switch, and the ability to use almost any switch that you want since it does not have to be rated to carry the current from the device. Further, the EFIS can be used as a backup to turn devices on and off if the switch itself fails.

There are 10 switch inputs that can be used for things like avionics, boost pump, lights, and other items on the aircraft. There are an additional 4 dedicated inputs for pitch and roll trim switch inputs and 2 more for flap switch inputs.

Each switch is wired to ground on one side, and the other side is wired to one of the switch inputs as shown in the diagram below. You can use 20 or 22 AWG wire.

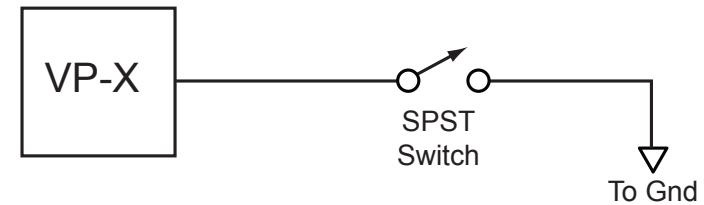

Switches do not carry loads, they simply provide a ground to the switch input pin, which then enables the VP-X to turn devices on and off.

Later on you will configure each power pin using the Online Planner, and later, your laptop connected to the VP-X. Each pin can be configured for a specific circuit breaker value, name and switch assignment. When the specified switch input is grounded, the device or devices assigned to that switch input turn on. When the specified switch input is not grounded, the device or devices are off.

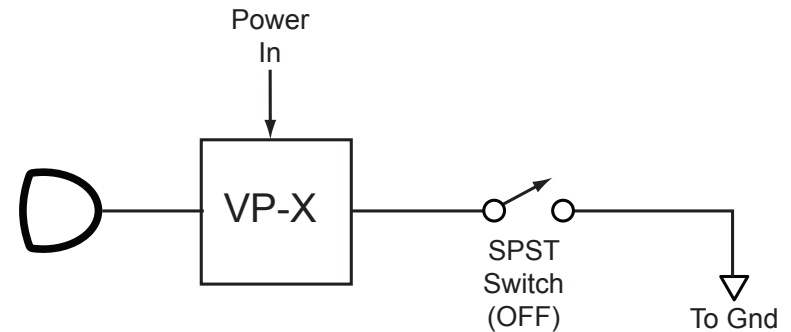

Above, switch is open so lamp is off.

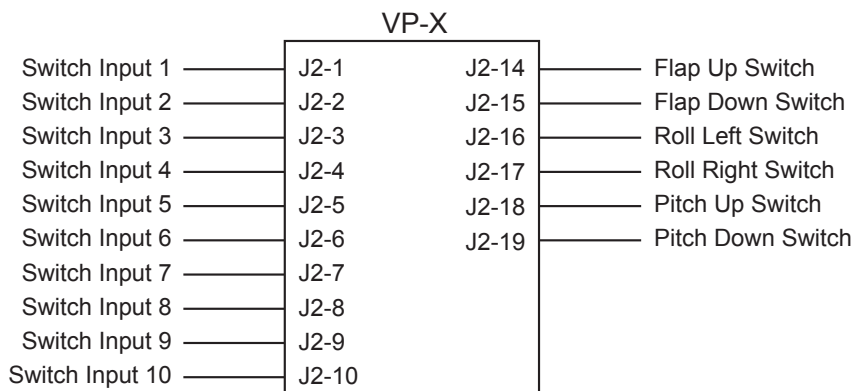

VP-X Switch Inputs

(J2-1, for example, means connector J2 pin 1)

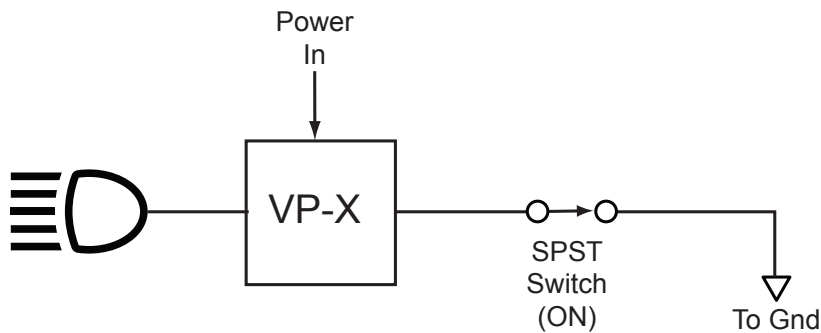

Above, switch is closed so lamp is on.

Here you can see that the light turns on when the switch is closed, and the actual power switching is done inside the VP-X and not by the switch. The switch simply tells the microprocessor to turn on the device(s) associated with the switch.

Note that the starter circuit and master switch circuit are different and explained elsewhere in this manual.

4.3 Wiring Harness

A VP-X wiring harness is available to simplify the installation of electrical system. Appendix B at the end of this manual details the contents of the wiring harness kit.

4.4 Dual Bank Technology (VP-X Pro)

The VP-X Pro includes our Dual Bank technology that has two independent power banks in a single system, delivering unprecedented levels of redundancy and safety. Builders can now easily divide avionics and other electrical loads between two power banks, and should one bank controller fail the other bank will continue to operate independently and be able to provide power to the starter contactor. Each bank of circuits is powered by an independent power supply and microprocessor.

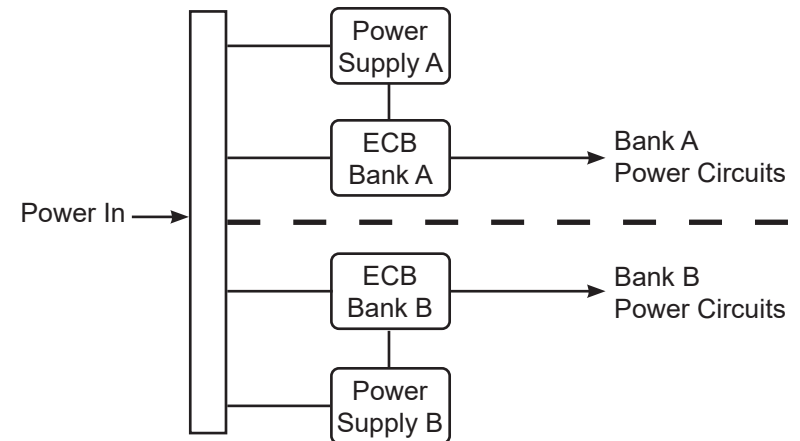

Overview of Dual Bank Technology

The power pins associated with each bank are shown in Appendix A.

It is important to understand the following:

- Each switch input (1 through 10) can be read by either microprocessor. Devices on both bank A and bank B can be controlled by a single switch input. For example, the landing light switch can control BOTH the left light (wired to bank A) and the right light (wired to bank B).
- The two banks do not share common components on the circuit board – each bank is isolated from the other outside of the main power bus (input) and ground.
- Either bank (A or B) can power the starter circuit. Therefore if a bank fails you can still start the engine.
- Pitch trim is controlled by both processors. Both processors must agree to run the pitch trim before it can run. Therefore, if either bank fails the pitch trim cannot operate.
- The roll trim is powered by bank A.
- The flaps are controlled by bank B.
- The serial and Ethernet lines are connected to the bank A microprocessor. If bank A fails then communications with the EFIS are lost. In this case, bank B will continue to operate normally but you will not receive status on the EFIS.
- Bank A provides the reference voltage to the trim and flap indicators.

Dual Bank technology should be used as a tool to mitigate risk in the case of a system failure within the VP-X, and not as a tool to mitigate risk of a larger system failure. Be sure to understand the failure modes you are solving for. Dual Bank technology provides redundancy if a power supply or microprocessor in the VP-X itself fails (an extremely rare event). It does not solve the problem of a failed master switch, battery contactor, or contactor (main bus) wiring. To solve for these failure modes, install a backup circuit (Method B or C) as discussed later in this manual.

If you have redundant devices like radios, lights, or displays, then you can divide those up between Bank A and Bank B so that each bank has one of each type of device. That way if a VP-X bank fails, the redundant device on the other bank still has power. Spend some time planning possible failure modes and divide the devices between the two banks. For example, if you have two comm radios, put one on each bank. If you have a taxi light and a landing light, put one on each bank.

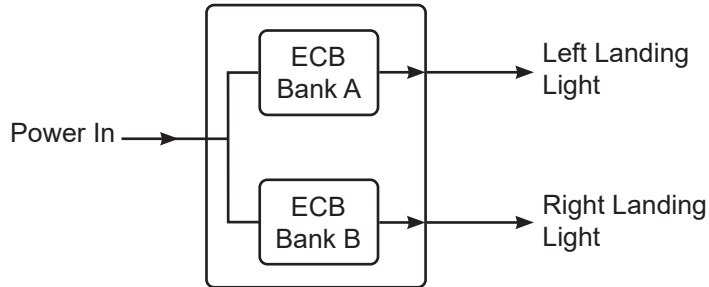

Redundant devices, one on each bank.

Some avionics have two power inputs but each is for a distinct function. Do not split these power inputs between banks. For example, a Garmin 750 has a nav power and a comm power input. These should be wired to two separate pins on the same bank.

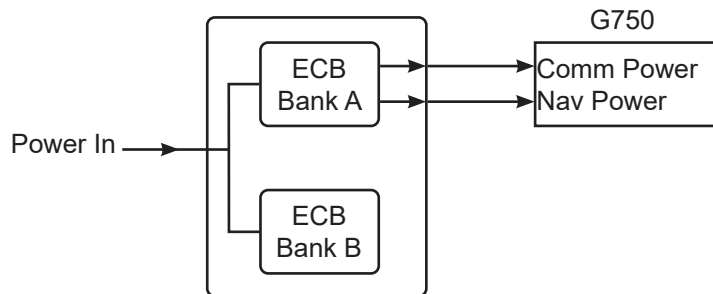

Two power inputs to a device should come from the same bank.

If a device has only a single power input, you should use backup Method B (described later in this manual) to back up this circuit. Do not wire power from both banks, as this does not provide backup in case of a failure of the battery contactor or master switch.

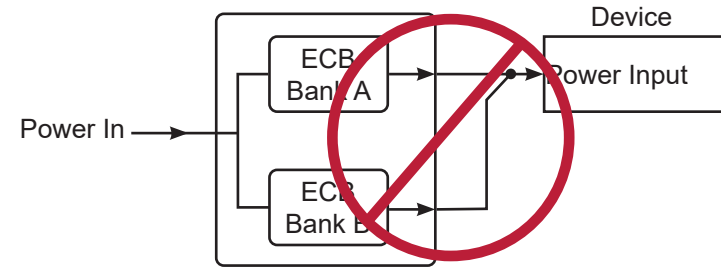

Use backup Method B instead of this.

If an avionics device has dual redundant power inputs (most modern EFISs do), you should use backup Method C (described later in this manual) to back up this circuit. Do not wire power from both banks, as this does not provide backup in case of a failure of the battery contactor or master switch.

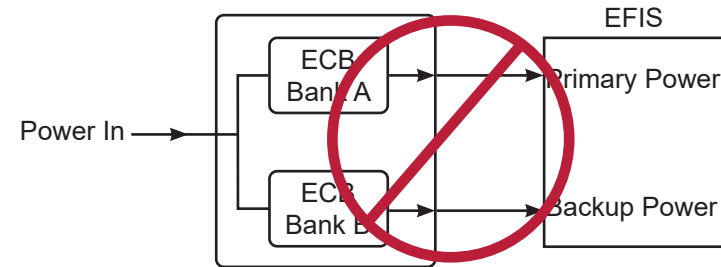

Use backup Method C instead of this.

4.5 Tools and Other Stuff

This is a generic list of items to assist with planning. Some items may vary depending on the requirements of your specific installation.

Things you will need

- Crimper - insulated terminals 10 to 22 AWG
- Crimper - d-sub machined barrel male
- Crimper – terminals for 2 to 8 AWG wire
- Stripper(s) – for wire 14 to 26 AWG
- Starter contactor (Optional, PPS Preferred)
- Battery contactor (Optional, PPS Preferred)
- Heavy gauge wire for “main” power runs
- Heavy gauge wire terminals (non-insulated)
- Alternator(s) and voltage regulator(s)
- Wires for data interconnects on avionics
- EFIS – for VP-X status and setup
- Ray Allen Co. POS-12 flap position sensor (optional)
- Momentary up and down (on)-off-(on) flap switch. All sticks can be ordered or retrofit with this switch type.
- Magneto/starter switch
- Switches



Be sure to use a momentary up and momentary down flap switch (on)-off-(on). Most flap switches come standard in a non-momentary up configuration on-off-(on).

Things you won't need

- Battery contactor and starter contactor if using PPS (preferred)
- Flap Positioning System
- Flap Controller
- Flap over-speed module
- Trim Controller
- Trim speed controller
- Wig-wag module
- Trim or flap position indicators

- Trim relays
- Trim voltage regulator
- Avionics relay
- E-bus diode
- Circuit breakers/fuses (except for backup circuits)
- Shunts/hall effect sensor
- Over-voltage module
- Low-voltage alarm

4.6 VP-X Connectors

The photos below show the different connectors used in the VP-X, the big, higher-amperage power connector on the left and the smaller, low-amperage d-sub connector on the right.



Power Connector



D-sub Connector

There are six connectors on VP-X Pro and five on the VP-X Sport. Three of these connectors, identified as J8, J10, J12 (corresponding with the number of pins on the respective connector), carry high-current loads. J8 is not installed on the VP-X Sport.

The two d-sub connectors, J1 & J2, are used for low-current purposes such as trim motor operation, position feedback, serial data, and switch inputs. J1 is the top connector. It is male. The connector on the wiring harness is female. J2 is the bottom connector. It is female. The connector on the wiring harness is male.

The top Ethernet connector is used to communicate with a Windows PC for configuration and software updates. The bottom one is not used.

The VP-X connectors are shown in the diagrams below:

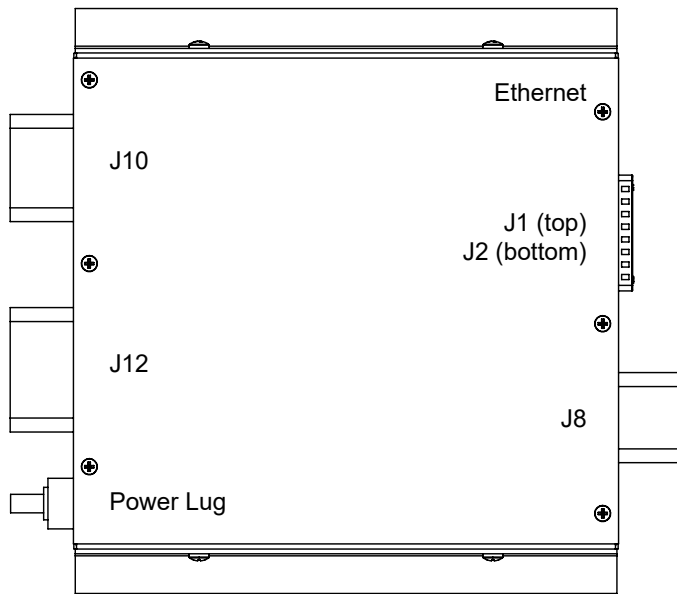

Shown with mounting brackets installed.

A view of both ends is shown below.

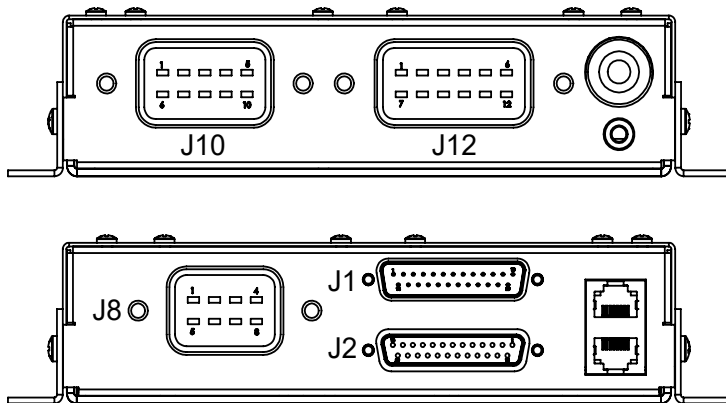

J1 is the top 25 pin d-sub connector and it is male. It mates with a female connector that contains the wiring harness.

J2 is the bottom 25 pin d-sub connector and it is female. It mates with a male connector that contains the wiring harness.

4.7 Installing and Removing Power Connector Terminals

The large (black) power connectors allow you to easily install and remove the wire/terminal assembly.

4.7a Installing terminals

Step 1: Insert a small screwdriver (max width= 1/8 inch, about 3.0 mm) into either pry point

Step 2: Using the housing as a pivot point gently pry out on the white insert, until it reaches pre-lock position (5.0 mm travel)



Insert screwdriver



Gently pop up white section

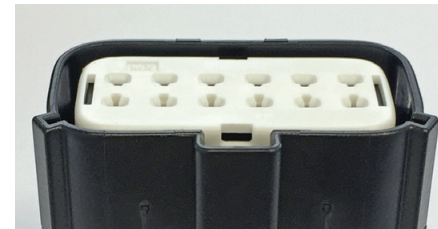

Before



After



The white insert should never be removed. If it is removed, discard the entire connector. Do not attempt to re-assemble. Contact Vertical Power Support for information regarding replacement connectors.

Step 3: With the white insert still in the 'out' position, align the terminal to rear of connector. Align the orientation feature as shown and insert through appropriate opening. If resistance is encountered, retract the terminal and adjust the angle of insertion. Continue inserting the terminal until it stops with an audible click. Give the wire a slight tug to make sure it is seated properly. It should not come back out.

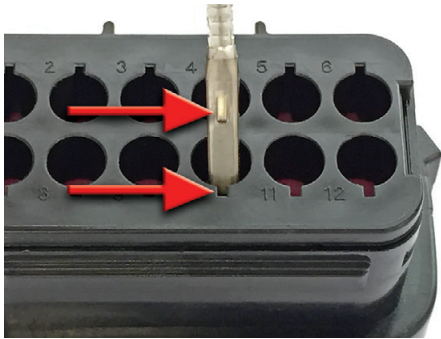

Orientation feature on terminal aligned with index on housing

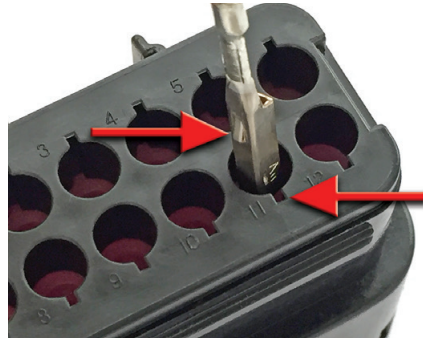

90° mis-orientation
Not a straight entry

Troubleshooting:

The terminal should insert smoothly into the connector housing. If it does not, the following are the most likely causes:

- The terminal is rotating while you are inserting it. The terminal must remain aligned until it is fully inserted.
- The tangs on the insulation crimp may not be fully closed. Gently squeeze the tangs closed around the insulation with a pair of pliers.
- The white insert may have closed. Open the insert.

Step 4: With the terminals fully installed, the white insert can be seated into its final lock position by applying an even force to both ends until it comes to a stop, with an audible click. The white insert should move a distance of 5.0 mm (about 1/4").

4.7b Removing terminals

Steps 1 & 2: Follow these steps as shown above to raise the white part of the connector.

Step 3: Using the pin removal tool, insert the tip into the terminal service hole adjacent to the terminal to be serviced.

Step 4: Push down gently to release locking finger. You will hear a gently click. **Do not apply any lateral force, as this may damage the connector or the terminal!**

Step 5: With the white insert still in the 'out' position, gently pull on the wire to release the terminal.

If the terminal resists, the service tool may not be fully engaged. Remove the tool and re-try. Push the service tool further into the service opening to ensure that it has fully disengaged the locking finger.

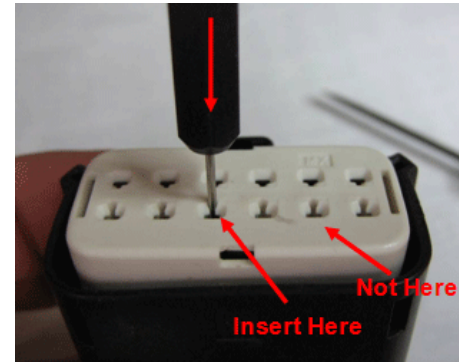

Do not insert the tool into the terminal opening!

Do not use excessive force, excessive force can damage the connector!

Step 6: The white insert can be seated into its final lock position by applying an even force to both ends until it comes to a stop, with an audible click. The white insert should move a distance of 5.0 mm (about 1/4").

4.7c Pin Removal Tool

A pin removal tool is included with the wiring harness or connector kit.

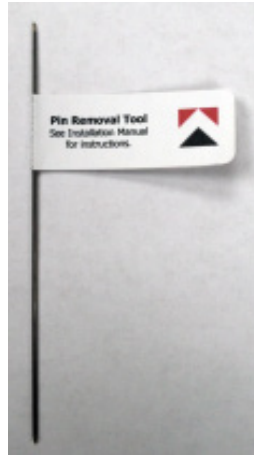

Pin Removal Tool

If the pin removal tool is not working as expected, use a Scotchbrite wheel to grind the end of the pin removal tool as shown below.

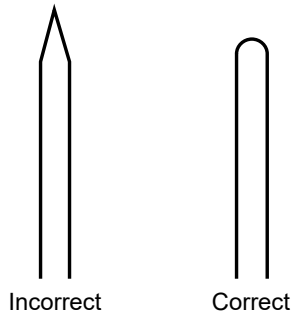

4.8 Alternator and Voltage Regulator Considerations

Choosing the correct alternator and voltage regulator is an important part of planning your electrical system. The VP-X supports internally and externally regulated alternators, as well as the B&C SD-8 permanent magnet alternator. We do not take a position regarding which type or brand of alternator is best.

The VP-X does NOT replace the voltage regulator. Externally-regulated alternators require a voltage regulator.

The typical automotive-style voltage regulator does simply that – regulates the voltage to the field wires on the alternator. Varying the field voltage affects the output capacity of the alternator. Higher voltage means a stronger field to generate current which means more output. An internally regulated alternator provides the same function, but the regulator is housed in the alternator itself.

Certain internally regulated alternators provided by Plane Power, Ltd. (<https://planepower.aero/>) have built in over-voltage protection. All alternators built by Plane Power are compatible with the VP-X system.

Externally-regulated alternators have the regulator in a separate box outside the alternator. Most voltage regulators provide only the voltage regulation function, and some allow you to adjust the voltage level. The B&C LR3C/LR3D (<https://bandc.com/>) external voltage regulator provides three functions: 1) voltage regulation, 2) under-voltage alerting, and 3) overvoltage protection. It is generally regarded as a high-quality product that has been through years of field experience. Note: B&C does not recommend the LR3C/LR3D be connected to PTCs (Positive Temperature Coefficient thermistor) for circuit protection. The VP-X does not use PTCs for the power circuits and is compatible with B&C voltage regulators.

There is a long-standing and unresolved debate in the experimental community about the benefits of internally versus externally regulated alternators. The table below shows some of the pros and cons of each type.

Some common backup alternators are the accessory-drive mounted SD-20 alternator and the SD-8 PM alternator, both available from B&C Specialty Products. The one you choose is driven in large part by the size of the loads you need the backup alternator to carry.

		Pros	Cons
	Internally Regulated Alternator	Simple to wire No external boxes	Certain failure modes will cause over-voltage condition that cannot be stopped by removing power from the field wire*.
	Externally Regulated Alternator	Separation of VR from alternator, and each can be serviced separately. Removal of power from regulator shuts down alternator.	Extra box to install and wire Extra cost and weight

4.8a Over-voltage Planning

An over-voltage condition is initiated by a failure in either the voltage regulator or the alternator which causes the voltage to rise above a safe level for the avionics and other electrical equipment. Typically the over-voltage level is set at 16.0 volts for a 14v system and 32.0 volts in a 28v system.

Over-voltage protection is provided by the VP-X, and therefore an external device is not needed for this function. Over-voltage protection is provided by removing power from the Field wire when the bus voltage exceeds a pre-set limit for a pre-set period of time. If your system comes with an overvoltage protection circuit, the VP-X system is compatible with “crowbar” type circuits. These simply short the alternator field wire to ground, causing the field circuit breaker to pop.

4.8b Low-voltage Planning

During flight, the normal bus voltage should be around 13.8 to 14.2 volts. A low voltage condition is most likely due to one of the two following circumstances:

1. The alternator has failed causing the bus voltage to drop from 14.2v to 12.4 volts or less (double for a 28v system).
2. The electrical loads on the aircraft exceed the capacity of the alternator, which is unable to keep the battery fully charged. The bus voltage will slowly decline until the low voltage alarm is triggered.

The low voltage alarm may be provided through the EFIS.

4.9 Landing Light Wig-Wag (Pulsing) Considerations

Various circuits can be configured to wig wag external lights. In order to flash two different lights, they must each be wired to a separate pin on the VP-X. Lights that are wired together to a single pin cannot be flashed separately (although they can be flashed together). Wire each light that you want to flash independently to separate pin.

In the setup menu, you specify which power pins you want to wig wag. It then alternates power on those pins. For example, if you configure two lights, a taxi light and a landing light, then those two pins will wig-wag or pulse. Pulsing begins automatically above a specified airspeed so the lights are always steady on the ground and pulsing when in the air. You can specify the warm up time (5 secs to 60 secs), and the light is steady on for the specified time period before pulsing.

Some LED landing lights include a built-in wig wag function. We recommend using the wig wag built into the VP-X, which includes additional features and also simplifies wiring.

4.10 HID Light Considerations

HID lights draw about double their normal power during the first 30 seconds or so of operation. Because of this, all HID lights must individually be connected to a 10A circuit, set to a 10A breaker value.

4.11 Electronic Ignition Considerations

The VP-X can be used with various electronic ignitions (EI) as long as the appropriate safety considerations are taken into account. Most EIs, such as Lightspeed or E-mags, require external electrical power to operate. Others, such as P-mags or Lasar, have internal backups and can operate with or without external power. P-mags require external power for starting and idle.



Make sure that at least one ignition source is wired directly to the battery as per the ignition manufacturer's instructions if you are running dual EIs that require external power!

If at least one magneto or p-mag is installed, you can provide power to the other ignition via the VP-X. Consider using some form of Backup Circuit to provide power in case of multiple failures (failure of the magneto and failure of the VP-X at the same time-unlikely but possible).

Some examples are shown below, and are meant to be guidelines only.

The builder is responsible for determining the appropriate level of redundancy for his or her aircraft:

- Dual Lightspeed or e-mag ignitions: wire one directly to the battery (per manufacturer's instructions) and one to the VP-X. Or, wire both to the batteries per the ignition manufacturer's diagram.
- One Lightspeed/e-mag and one magneto: wire the Lightspeed/e-mag to the VP-X.
- Dual p-mags: wire both to the VP-X.
- One e-mag and one p-mag: wire both to the VP-X on individual power pins.
- Dual magnetos: neither is wired to the VP-X, as they don't require external power.
- Lasar: Wire the Lasar power to the VP-X. The magnetos act as backups.
- G3: Wire the G3 power to the VP-X. The magnetos act as backups.
- Rotax: has its own built-in alternator that is always on and wired separately from the VP-X.
- Jabiru: has its own built-in alternator that is always on and wired separately from the VP-X.

4.12 Electric Motor Considerations

The VP-X is designed to drive the flap and trim motors with special circuits designed for that application. The VP-X can power smaller motors like avionics fans or defrost fans.

Do NOT use the VP-X regular power circuits to provide power to medium or large electric motors like gear extension/retract motors (including canard nose gear) or hydraulic pumps. This also applies to motors in linear actuators that may bind at the end of their travel. Those motors should be wired directly to the main power bus outside of the VP-X.

4.13 VP-X Planner

You will find that the VP-X Planner has many uses. It can be used to:

- Plan pin connections prior to configuration
- Analyze overall electrical system loads
- Aid while wiring your aircraft
- Document the wiring in your aircraft for future reference

We recommend reading the Installation section of this manual prior to completing the worksheet.

You can find the VP-X planner at <http://planner.verticalpower.com/>



Follow these steps. Additional details are provided in the planner itself and the in the next section:

1. Register or log-in
2. Complete the System Settings tab. *SELECT ELECTRIC FLAPS*. You can change this later in the configurator program if you do not have electric flaps. Press 'Save your config' button.
3. Build an inventory of all your electrical devices under the Devices & Pins tab.
 - a. Alternators, trim and flaps are configured under the System Settings tab.

4. Select the Switches tab and edit the standard switches to match the actual switches in your cockpit. Please read How Switches Are Wired in section 4 of this manual.
 - a. Note that the master switch is wired directly to the PPS (or alternatively to the master contactor) and not through the VP-X.
5. Go to the VP-X Pinout tab and assign each of the devices to a power pin. You can do this automatically or manually, or some combination or both. You can move devices to other pins manually too.
 - a. Be sure that the EFIS to which the serial data lines are wired is powered by pin J12-9. J12-9 is factory set to always on. The planner allows a switch assignment, but in operation, it will be always on. Set to always on when planning.
 - b. Note that the starter, EFIS, primary alternator, trim and flaps have their own dedicated pins.
 - c. There are two ground wires that must be wired to airframe ground. Ground wires can be 18AWG wire from J10-9 and J12-4.
6. The following are additional resource for you:
 - a. Elec. System tab draws an electrical diagram for you based on your configuration.
 - b. Request review link at top of page sends a request to VP to review your configuration. The request is sent when you click this link so please only press it when you need help or need a review.
 - c. Printable Config or Diagram link at top of page brings up a PDF file that you can print. This is a large-format paper, which you can scale use Adobe Reader when printing.
 - d. Share allows you to share your config with friends.

The Planner includes pinouts for J8, J10, J12, J1, and J2. J8 is not installed on the VP-X Sport. "J" is a term used to name a connector.

The planner uses both pinouts (like J12-8) and circuit number assignments (like 5A-8, which means it is a max 5 amp circuit, and the 8th one.) The latter is how you will reference them during setup.

The fields in the *Devices & Pins* tab of the Planner is explained below:

- **Pin Name:** You can give each pin a name that shows on the EFIS display.

- **Max Amps:** The maximum current load that a pin is capable of handling. A load drawing more than this amount of current will fault (i.e., turn off) the load.
- **Actual Amps:** The actual current drawn by a device. It is recommended you measure the ACTUAL current draw of each device prior to installation in the aircraft using an ammeter. The total actual current draw should not exceed 60 Amps.
- **Circuit Breaker:** The maximum current allowed for that pin. You can enter any value between 1 and the limit of that pin in increments of 1A. This value is equivalent to a circuit breaker or fuse. If a load draws more than the Circuit Breaker value, that circuit will fault. If too large of a breaker value is used, then the wire may overheat or fail. If too small a value is used, then the device may fault the circuit because it draws too much current.
- **Switch:** Enter the number of the switch input (switch input 1 through 10) you want to control this pin, or set to 'always on' or 'always off'. Each switch input is labeled 1 through 10. You can assign multiple devices to a single switch, and conversely, a switch can control multiple devices. If you set the circuit to 'always on', it will be on anytime the VP-X is powered (i.e. the master switch is on). Multiple pins can be assigned to a single switch. Switch inputs are on J2, pins 1 through 10. You don't have to use all of the switch inputs.
- **Current Fault:** The pin can be configured to detect a "current fault" or open circuit. When a circuit with this feature enabled is turned on and does not draw any current for 3 seconds, the circuit is faulted. You can use this to detect burned out lights, faulty boost pump, failed avionics fan, or inop heated pitot tube for example. The minimum detectable current is about 100ma, so this should be used on devices like lights, strobes and loads that draw at least 100ma of current.
- **AWG:** The size of the wire based on the industry standard American Wire Gauge. This is the minimum recommended size wire for this circuit. Do not use a smaller gauge (bigger gauge number) wire.

4.13a What if I run out of power pins?

There are several options if you have more electrical devices than power pins on the VP-X. Evaluate each of the following and choose the one that makes the most sense for you:

1. Combine several devices together on a power pin. Typically these are low-current devices that are all switched on and off together. Since the circuit protection is designed to protect the wire, you can

group items as long as the CB value does not exceed the specs for the smallest wire. For example, an XM receiver and CO detector could be combined on a circuit and set to 2A fuse. Downside is if one device faults, then both devices lose power.

2. Create an auxiliary bus by running an 18 gauge wire from one of the 10A power pins (set CB to 10A) to a fuse block with 6 or so fuse holders. From each fused tab, run a wire to the device. Do not install fuses rated at more than 3A, and ensure the total load does not exceed about 8A. Often devices that need a 1 to 3 amp fuse draw less than half an amp, so you can easily put 6 or 8 devices on a fuse block. When an individual fuse blows, the others are unaffected. All devices will be turned on and off together.
3. If you're wiring backup circuits, you may already have a fuse block designed to power the backup circuits. Run devices off this fuse block, through external switches.
4. Contact us at info@verticalpower.com for assistance.

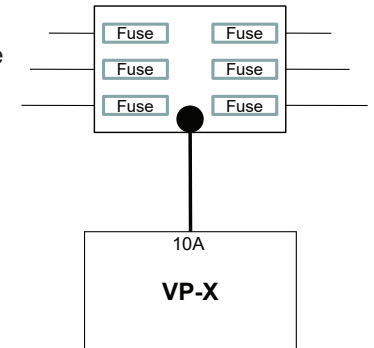

4.13b What if I run out of switch inputs?

If you need more than 10 switches (plus the master, trim, and flap switches), you can wire the switch in series between the VP-X and the device. We recommend using circuits with low-current loads like cabin lights, panel lights, or other similar devices. Doing so allows you to use the same style of switch for all devices (you don't have to install a special high-current switch). Wire as shown in the diagram below:

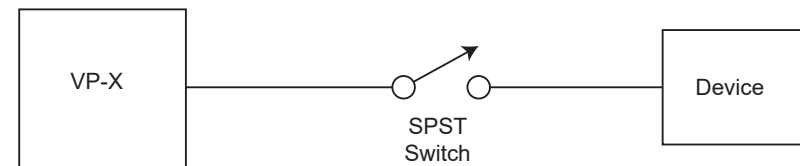

Unlike the other switches, this switch must be rated to carry the current load of the device.

5. Installation

This section walks you through wiring the power wires for the aircraft. The VP-X is the heart of the wiring system in your aircraft, and careful planning up front will make the installation process fairly straightforward.

5.1 Pre-Installation Tasks

	Disconnect battery before installation.
---	---

Before you begin the actual wiring, be sure to review and understand the wiring diagram. You must wire your aircraft to match the wiring diagram. Any deviations may cause unsafe or unknown results. Please contact Vertical Power Support if you have ANY questions.

Prior to installation and wiring, the following should be considered:

- The battery(ies) in the aircraft should NOT be connected until the wiring is installed and each circuit is individually tested. Do not run wires while the battery is connected.
Tip: Disconnect the battery ground cable first, then the positive cable. When re-connecting, connect the positive cable first then the ground cable. Doing so ensures you won't spark the positive connection to the airframe.

	Be sure to connect battery polarity correctly as the VP-X does not have reverse polarity protection. The VP-X will be damaged when powered with polarity reversed.
---	--

- Consider bench testing the system and the devices prior to actually installing it in the aircraft. This allows you to become familiar with the system in a comfortable environment.
- Build the wiring harnesses to match your Online Planner diagram prior to installing in the aircraft. If the wiring harnesses are complete prior to installation in the airplane, you can "lay them in" the airframe.
- The easiest method is to run the wires from the VP-X to their destinations. For example, run the wire from the VP-X to the landing light area, along with a ground wire, and that circuit is basically complete.

- Use good quality, gold-plated connectors for intermediate connections. For example, you may want to use a connector for all the instrument panel wires that go to the rest of the airplane. Consider using a connector for all the control stick wires, so that you can remove it later if needed. Contact Vertical Power Support for more information on connectors.
- Plan the physical wire routing in your aircraft prior to installing the harnesses. Drill any necessary bulkhead holes and protect sharp edges with snap bushings, grommets or other suitable fastener.
- Leave room for service loops (extra lengths of wire), so that you can easily remove and install components later.

	Do not grind, file, deburr, or drill metal or fiberglass airframe components with the VP-X installed, as metal shavings may get inside the unit and cause internal short circuits and damage.
---	---

5.2 VP-X Installation

The VP-X is typically located behind the instrument panel, but may be mounted almost anywhere in the interior of the aircraft where it is protected from direct exposure to the elements.

When choosing a location for the VP-X, consider the following:

- The VP-X should be located inside the cabin, away from occupants and baggage.
- The VP-X is not water-resistant and should be located away from possible water exposure. If you have a tip-up canopy or believe it may occasionally be exposed to water, use RTV silicone sealant to fill the small holes where the case meets the end caps. Do not put sealant on the connectors.
- The VP-X should NOT be mounted to the firewall where it is exposed to direct heat.
- Locate where you can relatively easily access the VP-X and the power connectors for troubleshooting during installation and in the future.
- Air should be allowed to circulate around the VP-X. A fan is not required.
- Do not locate near sensitive equipment such as a compass or AHRS. While no known interference exists, you should test and verify that an operational VP-X does not affect other equipment prior to finalizing the equipment locations.

- Do not mount where occupants can easily touch, kick, bump, or otherwise disturb the VP-X.
- The wiring harnesses for the VP-X should be secured at a point near the VP-X.

Recommended VP-X mounting locations:

RV-7, 9, 10: horizontally under the intermediate bulkhead (located between the firewall and instrument panel) using fabricated angle aluminum brackets. The VP-X is positioned roughly above the rudder pedal assembly, mounted to the brackets/intermediate bulkhead. For easy access, the VP-X can be mounted hanging downward from the brackets.

RV-8: in the right foot well, behind the panel on the intermediate bulkhead, or on braces above the rudder pedals. Be mindful of water coming in through the baggage door.

Glastar: Behind the panel.

Lancair Legacy: on the avionics tray in front of the instrument panel, along the tunnel behind the seats, or in the aft section of the fuselage.

Lancair ES, IV-P: on the avionics tray in front of the instrument panel, forward of the door along the fuselage, or in the aft section of the fuselage (within the pressure vessel).

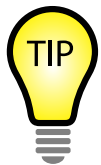

Note on mounting the VP-X in the rear of the aircraft:

You can mount the VP-X in the aft section of the aircraft, but be aware of the wire runs required for the switches. This may be attractive when space behind the panel is crowded. However, use of the standard VP-X wiring harnesses assume the VP-X is mounted up front near the instrument panel. You will need to modify the standard harness to accommodate the longer wire runs to the avionics and other equipment mounted in the front of the aircraft.

The VP-X uses two mounting brackets. Each bracket attaches to a side of the VP-X using two 6-32 screws. **DO NOT USE THE SCREW HOLES ON THE BOTTOM OF THE CASE TO MOUNT THE VP-X.** The brackets are pre-drilled to attach to the VP-X. The other edge of each bracket is not drilled so you can drill it as desired or rivet nut plates onto the bracket. The VP-X should be secured with a minimum of two screws on each mounting bracket. When considering the mounting sub-structure, remember that the VP-X only weighs 2 lbs.

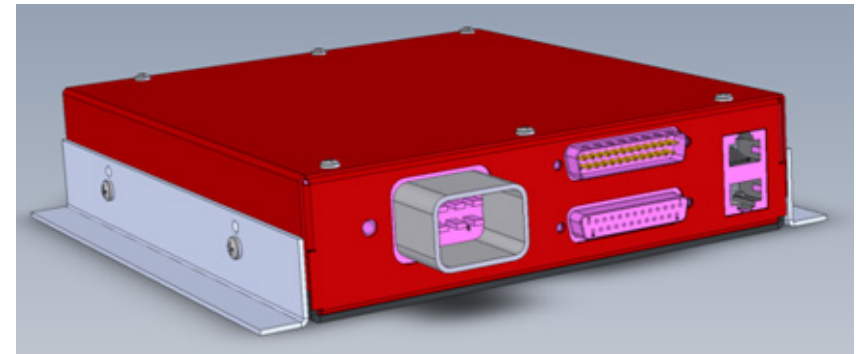

Mount the VP-X using two 6-32 screws on each side. Brackets shown are supplied with the VP-X.

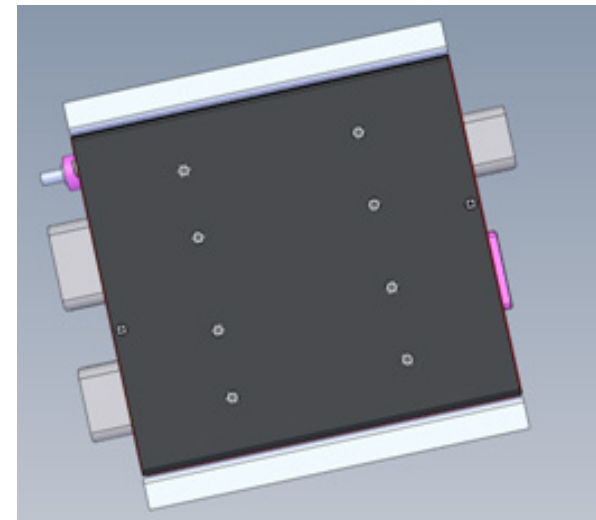

DO NOT use any of the eight threaded inserts on the bottom of the case to mount the VP-X.

VP-X mounting:

- Mount the VP-X so that it is securely attached to the mounting surface using the supplied mounting brackets or your own custom brackets.
- If mounting in a composite aircraft, or on non-conductive surface, run a wire from the VP-X chassis to the main ground block. Use a ring terminal around the mounting screws (the 6-32 screws on the side of the unit).

5.3 Wiring Harness Construction

Review the Connector Service Manual and Contactor Wiring Guide prior to proceeding with this section (available at www.verticalpower.com).

The connectors are labeled with the pin numbers next to each hole on the black side of the connector.

The wires in the wiring harness kit have a terminal pre-crimped to one end of each wire intended for use in the power connectors. The terminals for the power connectors require a special crimp tool. Contact Vertical Power Support for availability of this crimp tool. The d-sub wires come in longer lengths that you can trim to the desired length and crimp on the pins with standard d-sub crimping tool. Do not use generic crimp tools as doing so may result in a poor mechanical connection.

Construct the wiring harness following these steps:

- Using the Online Planner tool as a guide, and following the instructions in an earlier section about installing and removing wires, insert each wire into the correct location in each of the connectors.
- **Double check that the correct wires are in the correct pins in the correct connector**, based on your planned setup. Remove any unused wires from the connector. Additional wires can be easily added later.
- Begin by plugging the connectors into the VP-X and let the wires hang freely. Group the wires into bundles that go to a specific location in the aircraft. For example, group all the wires that go out to the left wing together.
- Run the bundles to their respective general locations. Keep in mind that ground return wires may also need to share space in the bundle as well.
- Secure the wires near the VP-X to minimize stress on the wires at the connector.

5.4 Backbone Wiring

Below is a diagram showing the major parts of the electrical system. Each section is described in detail in instructions below. Refer to the wiring instructions from the airframe manufacturer for wire sizing.

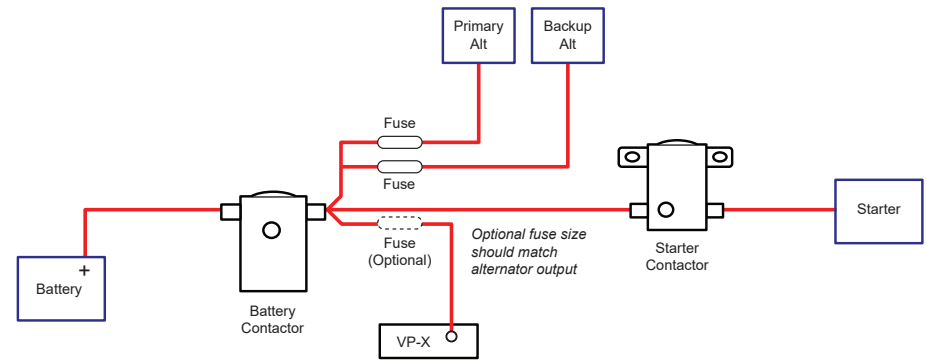

Backbone wiring diagram.

Note: Backup alternator can be tied to either side of battery contactor.

The following information is for the alternative method for primary power. It adds weight, wiring, and work. We recommend the PPS over the method described below. The diagram below shows a typical way to mount the contactors and fuses. This example is from an RV-7, and your actual installation may vary. In aircraft with aft-mounted batteries, the master contactor is located in the back near the battery, and the starter and fuses are located in the front on the firewall.

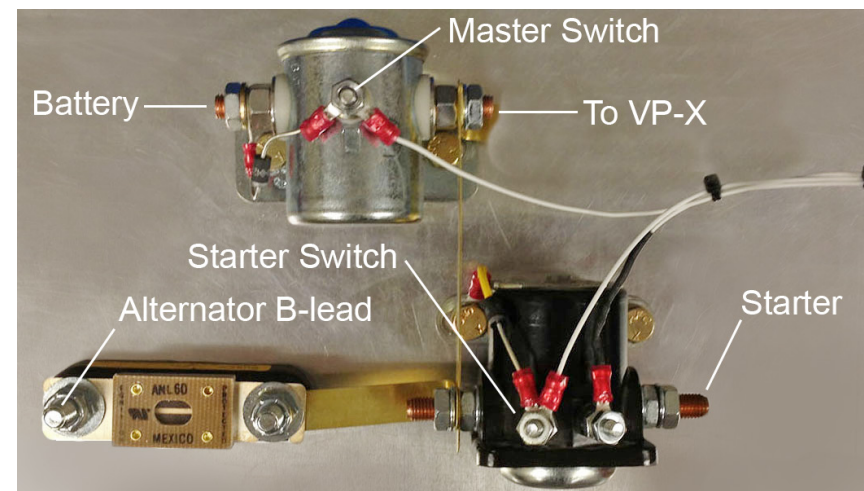

Typical contactor and fuse mounting (RV-7 shown)

The diagram below shows what each item is.

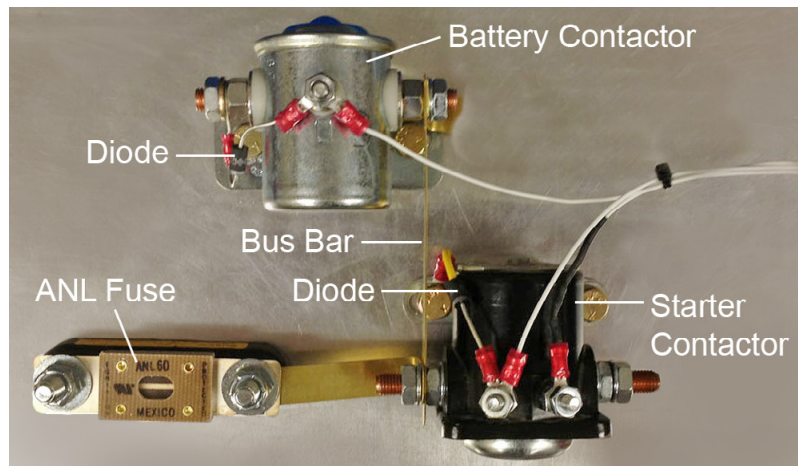

Description of items.

5.5 Master Contactor Wiring

Do not connect the battery until the system is wired and tested.

The master contactor (aka master relay, master solenoid) is controlled by applying ground to the small post on the contactor. Some contactors come with two small posts, some come with one. Be sure that you install a “continuous duty” contactor. The contactor typically draws less than 1 amp when energized.

- Connect the diode (included with the system) to the battery contactor as shown below. The diode will extend the life of the contactor, and may serve to minimize damage to sensitive avionics.

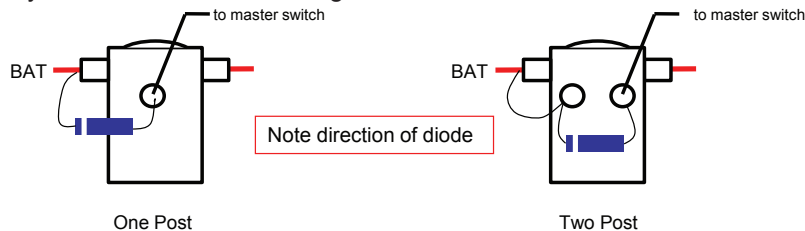

- Install a 20 AWG wire from the small post of the battery contactor to the master switch.
- Connect the other side of the master switch to ground.

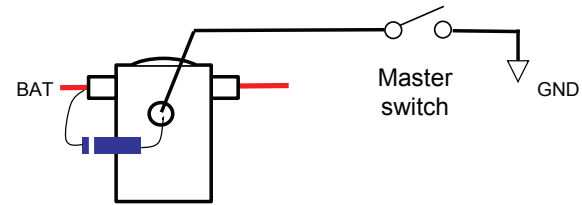

- Connect the main power wire from the battery contactor to the power lug on the VP-X using a 1/4” (0.250”) ring terminal. Cover with a molded plastic cover. You must use either a 6 or 8 AWG wire for this cable. Use 6 AWG if the run is over 4 ft or if the max planned load is >45 amps. Use 8 AWG for all other situations. Torque power lug nut to 36 in-lb (3 ft-lbs).

Do not over-torque the nut – all you need is a snug fit. The power lug is a soft copper alloy and will break if over-torqued. The nyloc nut will cause drag torque, be sure to account for this when torquing to 36 in-lb.

- Connect the cable to either the battery contactor post or the starter contactor post – they are electrically identical, but one may be more convenient than the other depending on your layout.

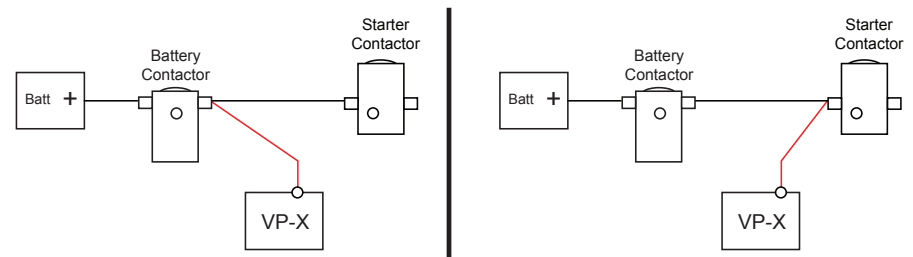

5.6 Starter Switch and Contactor Wiring

Function	VP-X Pin	I/O
Starter contactor coil power	J10-1	O

The PPS or a conventional starter contactor is controlled from a switch which is powered from J10 pin 1. J10-1 is ALWAYS ON (unless the engine is running) so a switch MUST be installed in between the VP-X and the PPS or the starter contactor.

With the Primary Power System (PPS)

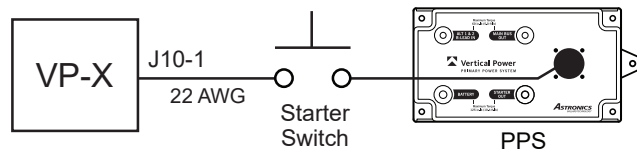

With a Conventional Starter Contactor

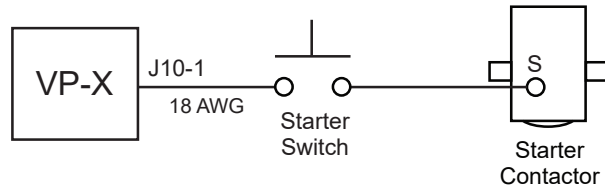

Do not connect the battery until the system is wired and tested.

- For PPS installation, run 22 AWG wire from J10-1 to the starter switch and 22 AWG from the starter switch to Pin 3 on the PPS. Set J10-1 to 1 amp.
- Alternatively, for a conventional starter contactor, install an 18 AWG wire from J10-1 to the starter switch. Then run an 18 AWG wire from the starter switch to the "S" terminal on the starter contactor (shown in the following image). Set J10-1 initially to 7 amps until actual amps are observed, then set trip value to 1-2 amps above actual.

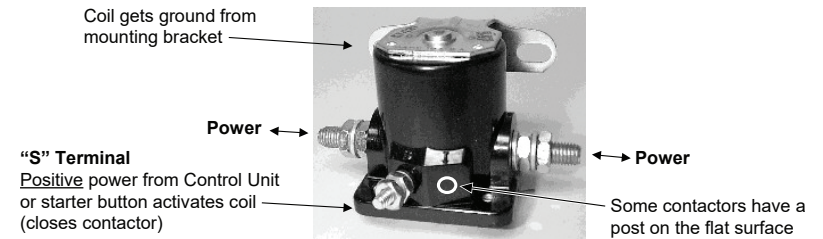

- Install a diode on the starter contactor coil as shown below. Note the direction of the diode.

The VP-X can operate down to 6 volts, so it will not reboot during normal engine starting. The VP-X does not boost voltage to any of the devices it powers.

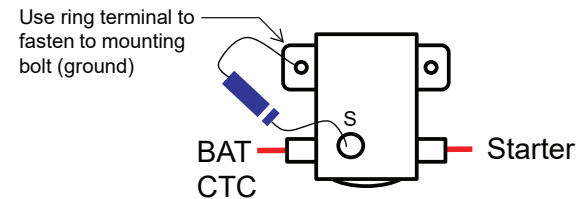

Disconnect the cable between the starter contactor and starter until the electrical system is completely tested.

If you are installing an Aircraft Spruce keyed ignition switch A-510-2 or similar, a drawing is provided below. It follows the same wiring as the example above, but shows the keyed ignition switch instead of a generic switch.

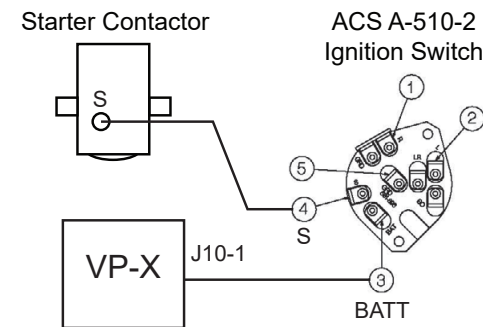

Starter wiring with a keyed ignition switch.

5.7 Starter Annunciator Wiring

Function	VP-X Pin	I/O
Starter annunciator input	J2-11	I

This pin measures voltage on the starter (or switched) side of the starter contactor and reports it to the EFIS for display. If enabled on the EFIS, an annunciator appears whenever the starter contactor is engaged.

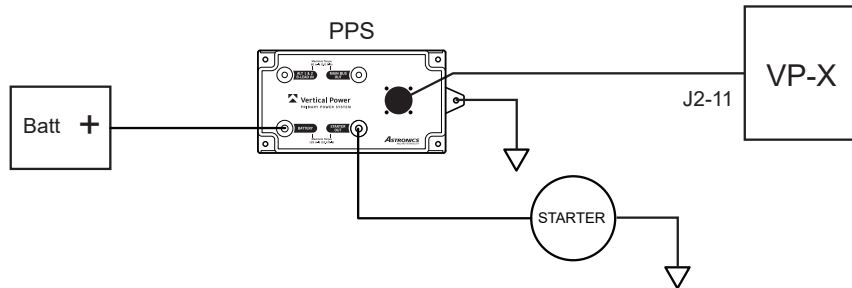

With the PPS, this is a simple connection to J2-11 on the VP-X. In a conventional system, a resistor should be placed in-line near the contactor to provide circuit protection for the wire.

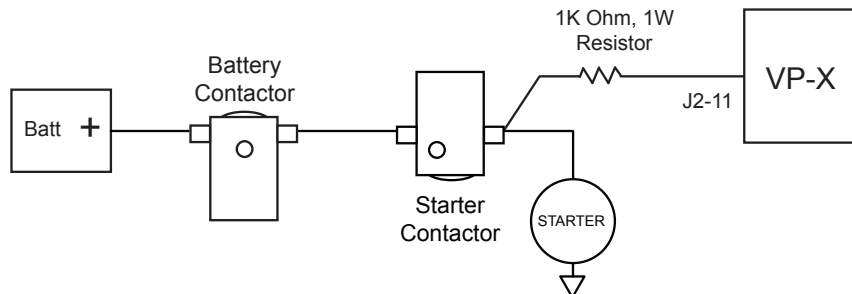

Option 1: Connect wire to switched side of starter contactor

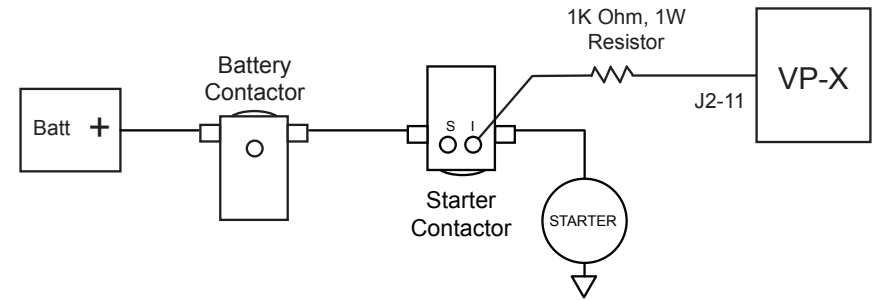

Option 2: Connect wire to "I" terminal on starter contactor, if it is present.

- Install a 20 AWG wire from J2-11 to the switched side of the starter contactor or "I" terminal. Install a 1K Ohm, 1 watt resistor in-line near the starter contactor.

TIP

Wiring Tip: The resistor is a weak spot in the wiring. The resistor itself is fragile, as is the small lead on either side of the resistor. To create a more secure joint, use the wire itself as a reinforcement. Solder the resistor leads onto the wire as shown below, keeping the resistor leads as short as possible. After soldering, cover the assembly with heat shrink to keep it securely held together.

5.8 Other Contactor Wiring

If other contactors (for hydraulic pumps, air conditioning, etc.) are installed in the aircraft, they must have diodes installed across the coil as shown above.

- Install diodes on the other contactors.

5.9 Alternator Wiring

The VP-X supports a single or dual alternator system. There are several types of alternators that are common among homebuilders, and each is shown in detail below. If your specific alternator or voltage regulator is not listed below, use the directions that came with it – it should be similar to the wiring described here. Or give us a call.

The VP-X does NOT replace the voltage regulator. Externally-regulated alternators require a voltage regulator.

The VP-X provides bus voltage (positive) power to the alternator field input or voltage regulator from J12 pin 11. This pin is configurable and you set its circuit breaker value up to 5 amps and assign it to be controlled by any of the switch inputs (or be always on). When the specified switch input is grounded by the alternator field switch, then J12-11 turns on. It works the same as the other power circuits with the following special considerations:

1. J12-11 turns off if there is an over-voltage condition and “overvoltage” is shown on EFIS display on the Alternator circuit.
2. If a secondary alternator is configured then only one alternator can be turned on a time. If one alternator is turned on when the other is on, then the most recent one to turn on remains on and the other is shut off, regardless of switch position.

The general wiring scheme for an alternator is shown below, and specific drawings are shown in the following sections.

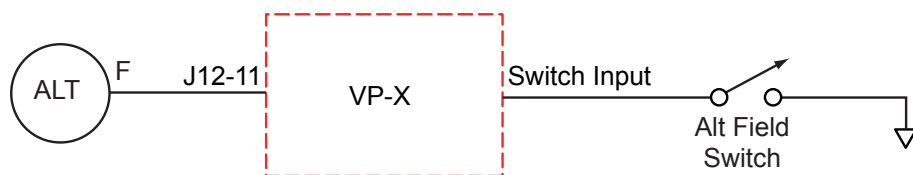

Correct way to wire alternator field and field switch

Do not wire the alternator field switch as shown below:

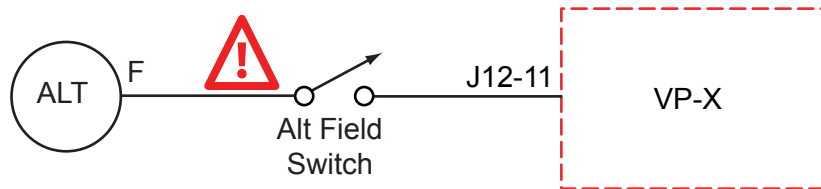

INCORRECT way to wire the alternator field switch.

The VP-X thinks the alternator is always on and therefore the synoptic and the device list on the EFIS are displayed incorrectly.

The wiring diagrams below show the use of 20 AWG wire for the alternator field circuit. The VP-X wiring harness use 18 AWG wire. The larger wire provides a bit more resilience in the harsh environment of the engine compartment. Electrically, though, either size wire is appropriate.

5.9a Primary Alternator (B&C External Regulator)

The B&C LR3C/LR3D voltage regulator can be used with several of the B&C alternators and other externally-regulated alternators. Do not use the SB1B regulator. The LR3C/LR3D requires a power wire for the field and the voltage sense wire, which senses the bus voltage in order to correctly regulate bus voltage.



When using the LR3C/LR3D external voltage regulator with the Vertical Power PPS, it is **IMPERATIVE** that you follow the PPS wiring diagram below or you will damage the PPS. Failure to wire the voltage regulator this way will void the PPS warranty.

These diagrams show the alternator wiring when using either the PPS or a conventional battery contactor; use the appropriate diagram for your system:

Wiring with Vertical Power PPS

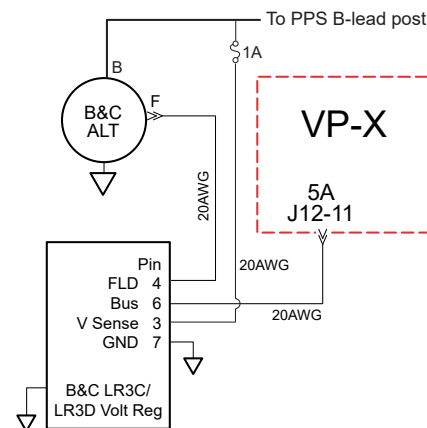

Wiring with Battery Contactor

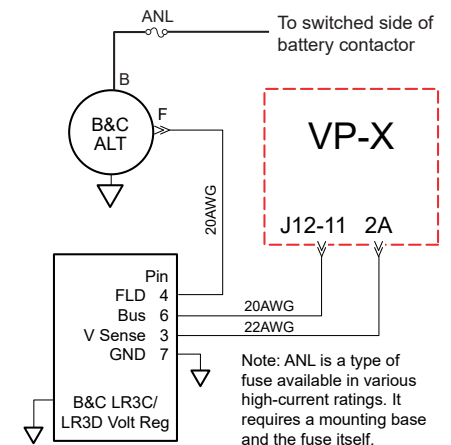

Note: ANL is a type of fuse available in various high-current ratings. It requires a mounting base and the fuse itself.

Wiring with the PPS	Wiring with Battery Contactor
<ul style="list-style-type: none"> Run a wire from the Primary Alt circuit (J12-11) to pin 6 on the LR3C/LR3D. This is the alternator field wire. Set the circuit breaker value for J12-11 to 5A later when configured. Run a wire from pin 3 on the LR3C/LR3D to a 1A external fuse and connect to PPS B-Lead post. This is the Vsense wire. Assign a switch input to J12-11. Do not install a switch between J12-11 and the voltage regulator. 	<ul style="list-style-type: none"> Run a wire from any 2A, 3A or 5A circuit to pin 3 on the LR3C/LR3D. Set the circuit breaker value to 2A later when configured. Run a wire from the Primary Alt circuit (J12-11) to pin 6 on the LR3C/LR3D. Set the circuit breaker value to 5A later when configured.
Final Steps	
<ul style="list-style-type: none"> Run a wire from pin 4 on the LR3C/LR3D to the field input on the alternator. Ground the LR3C/LR3D as per B&C installation manual. Run the B-lead wire from the alternator to the PPS B-lead post (no ANL fuse required), or alternatively to an ANL fuse on the firewall, then to the switched side of the battery contactor. The switched side is the large post on the opposite side of the contactor from the large post connected to the battery. The B-lead is typically a 6 or 8 AWG wire. NOTE: locate the fuse near the contactor. 	

5.9b Primary Alternator (Plane Power)

The Plane Power alternator requires a single wire for the field. It has a built-in voltage regulator. This diagram shows the alternator wiring:

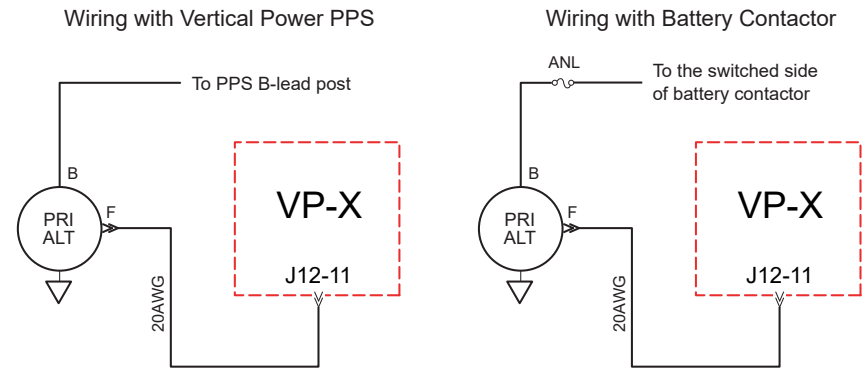

Note: ANL is a type of fuse available in various high-current ratings. It requires a mounting base and the fuse itself.

- Run a 20 AWG wire from the Primary Alt circuit (J12-11) to the field input on the alternator.
- Set the circuit breaker value to 5A later when configured.
- Run the B-lead wire from the alternator to the PPS B-lead post (no ANL fuse required), or alternatively to an ANL fuse on the firewall, then to the switched side of the battery contactor. The switched side is the large post on the opposite side of the contactor from the large post connected to the battery. The B-lead is typically a 6 or 8 AWG wire. NOTE: locate the fuse near the contactor.
- The alternator failure wire/output on the Plane Power alternator does not need to be connected. The EFIS will alarm when a low voltage condition exists, signifying that the alternator is not on or has failed.

5.9c Backup Alternator (B&C 20 Amp)

The B&C SD-20 20 amp backup alternator uses the LR3C/LR3D voltage regulator for 14 volt systems. If using the SD-20 on a 28 volt system, use the LS-1A voltage regulator from B&C. Do not use the SB1B regulator. The LR3C/LR3D requires a power wire for the field and for the voltage sense wire, which senses the bus voltage in order to correctly regulate bus voltage. *Note that you can connect the B-lead to the PPS B-lead post, or alternatively to either side of the battery contactor.* In a traditional configuration, use the switched side of the battery contactor (same as the primary alt). In some installations like an RV-10 where the battery contactor is in the rear of the aircraft, you can connect the B-lead to the un-switched side of the starter contactor, located on the firewall (it is electrically identical to the switched side of the battery contactor, saving you from having to run another wire to the back).

	<p>When using the LR3C/LR3D external voltage regulator with the PPS, it is IMPERATIVE that you follow the wiring diagram below or you will damage the PPS.</p> <p>Failure to wire the voltage regulator this way will void the PPS warranty.</p>
---	---

These diagrams show the alternator wiring when using either the PPS or a conventional battery contactor; use the appropriate diagram for your system:

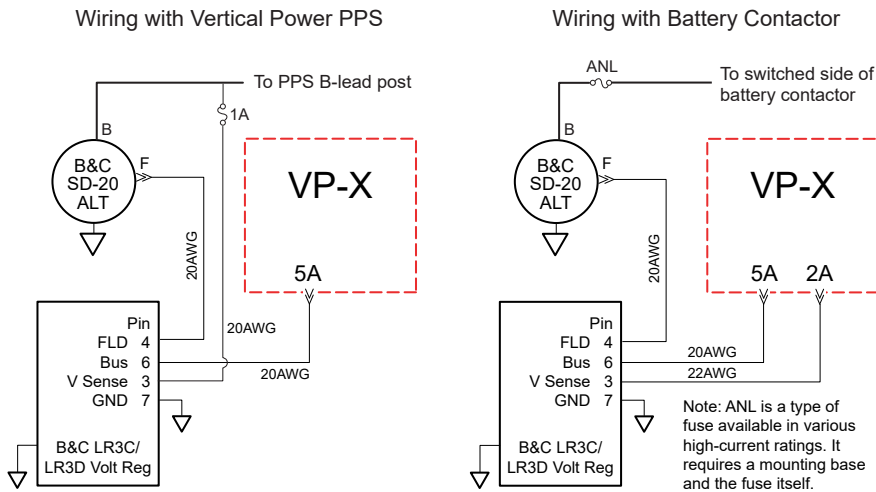

Wiring with the PPS	Wiring with Battery Contactor
<ul style="list-style-type: none"> Run a wire from any 5A circuit to pin 6 on the LR3C/LR3D. This is the alternator field wire. Set the circuit breaker value to 5A later when configured. Run a wire from pin 3 on the LR3C/LR3D to a 1A external fuse and connect to PPS B-Lead post. This is the Vsense wire. Assign a switch input to the chosen 5A breaker. Do not install a switch between chosen circuit and the voltage regulator. 	<ul style="list-style-type: none"> Run a wire from any 2A, 3A or 5A circuit to pin 3 on the LR3C/LR3D. (See LS-1A instructions for pin outs on that regulator) Set the circuit breaker value to 2A later when configured. Run a wire from a 5A circuit to pin 6 on the LR3C/LR3D. Set the circuit breaker value to 5A later when configured.
Final Steps	
<ul style="list-style-type: none"> Run a wire from pin 4 on the LR3C/LR3D to the field input on the alternator. Ground the LR3C/LR3D as per B&C installation manual. Run the 12 AWG B-lead wire from the alternator to the PPS B-lead post (no ANL fuse required), or alternatively to an ANL fuse on the firewall, then to the either side of the battery contactor. NOTE: locate the fuse near the contactor. 	

5.9d Backup Alternator (B&C 8 Amp)

The B&C SD-8 8 amp alternator requires a single wire to control the relay which isolates or connects the SD-8 to the bus. It uses the PMR-1 to regulate the voltage, which includes a regulator, capacitor, and battery. The Overtoltage (OV) crowbar module is not needed, as this function is included in the VP-X. The VP-X does not control the regulator directly, rather it open and closes a relay which allows the SD-8 output to flow to the bus. *Note that you can connect the output to the PPS B-Lead post, or alternatively to either side of the battery contactor.* In a traditional configuration, use the switched side of the battery contactor (same as the primary alt). In some installations like an RV-10 where the battery contactor is in the rear of the aircraft, you can connect the output to the un-switched side of the starter contactor, located on the firewall (it is electrically identical to the switched side of the battery contactor, saving you from having to run another wire to the back).

This diagram shows the alternator wiring:

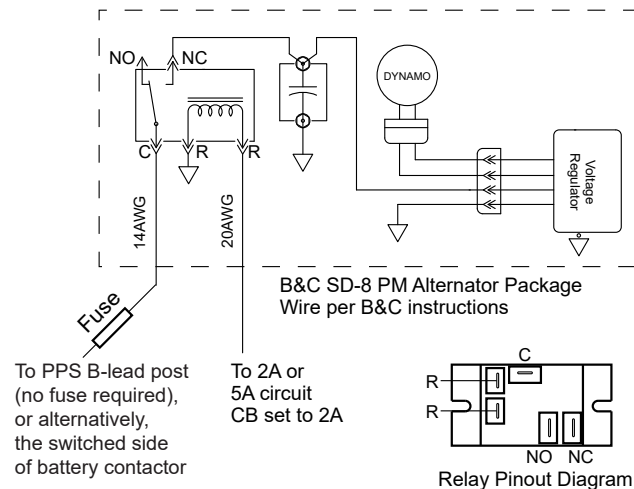

- Run a wire from a 2A, 3A or 5A circuit to the coil terminal on the relay that came with the PMR-1.
- Set the circuit breaker value to 2A later when configured.
- Connect the other side of the coil terminal on the relay to ground.
- Run a 14 AWG wire from the common terminal on the relay to the PPS B-lead post, or alternatively through a 10A fuse then to the either side of the battery contactor. NOTE: locate the fuse near the contactor (Note: fuse not required with PPS).

5.9e Backup Alternator (Plane Power 30 Amp)

The Plane Power backup alternator requires a single wire for the field. It has a built-in voltage regulator. The FS1-14 and FS1-14B are wired the same. We recommend using the FS1-14B, which is set to run at approximately 14.2 volts and can be turned on using the backup alternator switch. The VP-X will not let the primary and backup alternators be on simultaneously. Please contact Plane Power directly if you'd like further information about deciding which alternator to use. The VP-X works with either one. This diagram shows the alternator Wiring:

Wiring with Vertical Power PPS

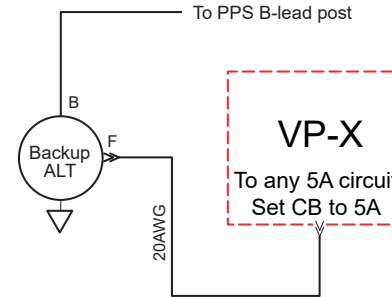

Wiring with Battery Contactor

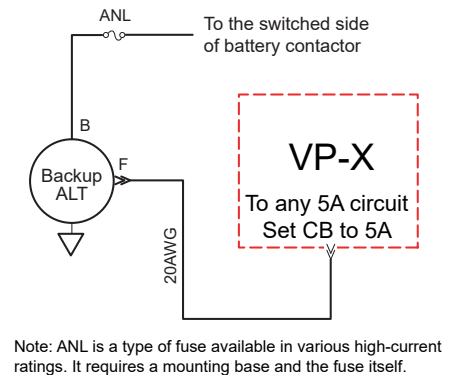

- Run a 20 AWG wire from any 5A power pin to the field input on the alternator. This pin will later be configured as the backup (or secondary) alternator.
- Set the circuit breaker value to 5A later when configured.
- Run the B-lead wire from the alternator to the PPS B-lead post (no ANL fuse required), or alternatively to an ANL fuse on the firewall, then to the switched side of the battery contactor. The switched side is the large post on the opposite side of the contactor from the large post connected to the battery. The b-lead is typically a 10 or 12 AWG wire.
- The alternator failure wire/output on the Plane Power alternator does not need to be connected. The EFIS will alarm when a low voltage condition exists, signifying that the alternator is not on or has failed.

5.9f Alternator – Rotax or Jabiru engines

Rotax and Jabiru engines have a built-in alternator/generator with their own regulator that typically mounts on the engine side of the firewall. They do not provide a standard method to turn on and off the alternator from the cockpit.

If you want to leave the alternator in its standard configuration where it is always on, then follow the manufacturer's instructions (shown below describing VP-X integration). When configuring the VP-X, disable the primary alternator circuit. (Note: SkyView users should leave it enabled until a future SkyView Software release supports the disabled alternator function, otherwise an alternator alarm will be on during the flight).

If you want to switch the alternator on and off, then insert the optional relay as shown in the diagrams below and control using the VP-X alternator control circuit, J12-11.

See the diagrams below for wiring overview.

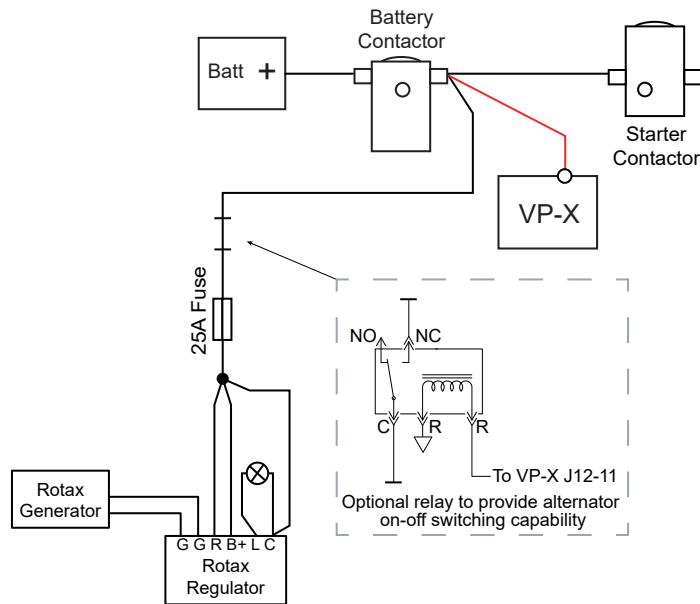

Rotax Installation

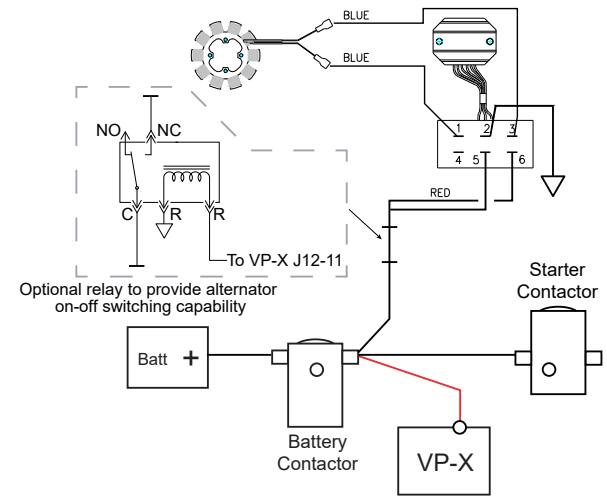

Jabiru Installation

The wiring diagrams shown above are for reference only to show how the VP-X fits into the overall bus architecture. You should consult the engine manufacturer's manual for the latest details and notes.

Use 6 AWG or 8 AWG wire from the battery contactor to the VP-X.

5.10 Primary EFIS Wiring – Power and Data Connections

The “primary” EFIS is unique because it is the EFIS that displays the faults and status from the VP-X. **This EFIS power must be wired to J12-9. The EFIS to which you wire the VP-X serial line must be the same EFIS that you run the power to J12-9. Note that this pin is ‘always on’ and cannot be set to a switch assignment.**

- Install a 20 AWG wire from J12-9 to the EFIS primary power input.
- If desired, install a backup circuit for the secondary power input on the EFIS. See “Backup Circuits” section later in this document.
- Connect the three data wires on the VP-X J1-20, 21, 22 to a serial data port on the EFIS. Typically serial data transmit and receive lines are grouped together on the EFIS. The transmit line (J1-20) on the VP-X goes to the receive line on the EFIS. Conversely, the receive line (J1-22) on the VP-X is wired to the transmit line on the EFIS. The VP-X communicates at 57600 bits per second.

“Which screen should I wire the serial line to?”

Below is our list of recommendations. PFD is the primary flight display usually right in front of the pilot that shows attitude information, and the MFD is the secondary display that usually shows maps. If you want to deviate from this, contact the EFIS manufacturer and ask them if your proposed configuration is supported.

- Advanced Flight Systems: PFD
- Dynon SkyView: both
- GRT Horizon or Sport: MFD or PFD
- Garmin G3X Touch, G3X: MFD or PFD
- MGL: PFD

5.11 Advanced Flight Systems EFIS Wiring

Wire to any serial port on either EFIS (if you have more than one). The VP-X screen as well as trim and flap position can be seen from any EFIS screen. Use a serial port pair on the EFIS. Make sure the EFIS and the VP-X are wired to the same ground. Do not use the serial ground on the VP-X.

5.12 GRT EFIS Wiring

On the HORIZON, trim and flap position are shared on the display interlink between display, but the status of each electrical device is not. The VP-X electrical page only appears on the display that is wired to the VP-X. On the SPORT, no data is shared between the displays, so wire the VP-X serial line to the display on which you want to see trim and flap position and VP-X electrical page.

Use a serial port pair on the EFIS. Make sure the EFIS and the VP-X are wired to the same ground. Do not use the serial ground on the VP-X.

5.13 MGL EFIS Wiring

Use any RS-232 port except for the dedicated NMEA port on the screen you want to see the list of electrical devices.

5.14 Garmin G3X Wiring

Wire to the MFD on a dual screen system if using a NON-Touch G3X. This is the screen that will show the electrical devices. The trim and flap position is displayed on any EFIS screen, but the VP-X electrical page is only shown on screen with the serial connection. Use a serial port pair on the EFIS, including the associated serial ground line. If using a G3X Touch, you can wire to either the PFD or MFD.

5.15 Dynon SkyView Wiring

In a dual SkyView installation, split both the transmit and receive lines and connect to both screens. You will then have a transmit and receive line going to each screen. The VP-X information (including trim and flap position) only shows up on the screen(s) to which a serial line pair is connected. Normally you cannot split the VP-X receive line, but Dynon uses a special schema that only transmits on one screen at a time, so the VP-X only receives from one screen at a time.

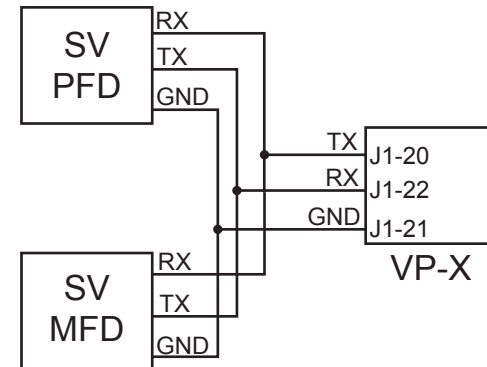

Wiring Diagram Overview (SkyView ONLY)

The diagram below shows wiring diagram detail using 20-24 AWG 3-conductor shielded wire (included in wiring harness kit).

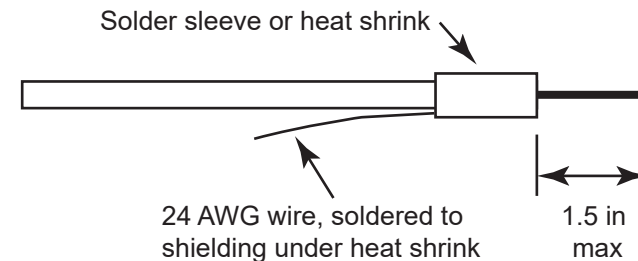

Shielding (single conductor shown)

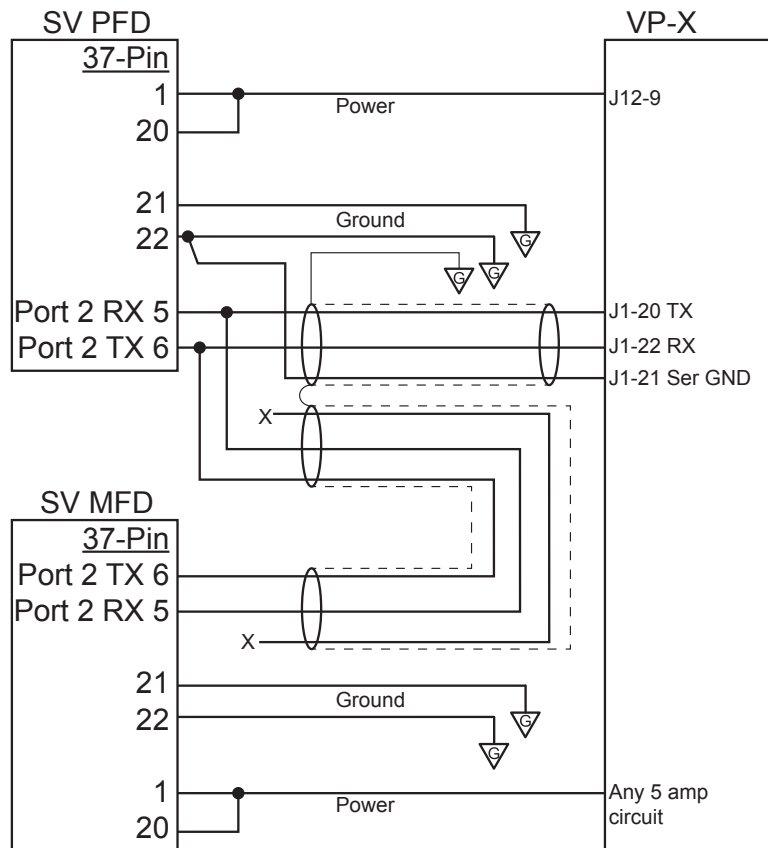

Dynon SkyView Wiring Detail; Wire grounds in locations shown. (Port 2 shown for example)

Notes on SkyView installation:

- TX = transmit port, RX = receive port, GND = ground.
- Use any open serial port pair on SkyView.
- Use any GND pin 21-24 on SkyView.
- Use 3 conductor shielded wire. Solder wires together within d-sub hood and cover with heat shrink. Run single wire into d-sub pin.
- The SkyView has two power pins on the display. These two power pins are simply to spread the load of a single power input across two power pins. These two power inputs must be soldered together into a single power wire. DO NOT wire each power pin on the SkyView to its own power pin on the VP-X. (see diagram below)

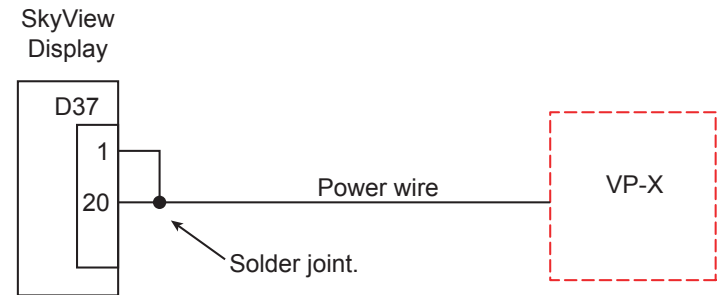

- Configuration instructions are located in the Configuration section later in this manual.

5.16 Items you don't have to wire to the EFIS

The following items are traditionally wired directly to the EFIS (optional of course) but are now integrated into the VP-X and the corresponding information is sent over a data line from the VP-X to the EFIS. Therefore, these connections are no longer needed at the EFIS.

- Shunts or hall-effect sensors to measure current
- Trim indicator wires
- Flap indicator wires

5.17 Ground Wiring

All ground wires from the VP-X, trim and flap switches, and panel switches should terminate at the same ground block. Ground wires from the avionics should all terminate at a single avionics ground bus. Most lights can be grounded to the airframe near the light itself. Be sure to follow the manufacturer's instructions for grounding for each specific device. Except for the trim and flap circuits, the VP-X switches only the positive wire and device grounds should terminate on the airframe or ground block.

The J10 and J12 connector each have a ground wire, and this wire is used to provide ground to the internal VP-X electronics, trim motors, and flap motor. The two wires are redundant in case one comes loose.

- Connect the two ground wires (J10 Pin 9 and J12 Pin 4) to the firewall or main ground block using **18 AWG** wire. Do **not** connect the two ground wires together and then run a single wire to the firewall. Both wires should be connected to the same ground block using an individual connector for each wire.

5.18 General Power Wiring

The VP-X has power pins on J8, J10, J12 and two on J1. These pins are all wired the same way. Run a wire, sized appropriately for the current load, from each power pin directly to the load. The connectors on J8, J10, J12 use the larger terminals and the black connectors, and the wire should be 14 to 22 gauge. The J1 connector uses standard male d-sub pins which can accommodate 20 to 24 gauge wire.

It is not required or recommended to use a capacitor of any size or type on VP-X outputs.

The following chart should be used to size wires.

Up to (amps)	Use wire size (AWG)
5A	20
10A	18
15A	14
Data signal	22
Trim & flap switch	22
Switches 1 – 10	22

The pin number is shown next to the hole where the wire is inserted on each connector.

- For each power pin, install a wire from the VP-X connector to the device. Use the Load Planning Worksheet as a guide.

Stray or Phantom Voltage – It is expected that circuit pins of a powered VP-X will display a random voltage reading (below bus voltage) on a digital multimeter when in the “off” condition. See “5.31 Testing Individual Circuits” on page 53 for more details.

5.19 Trim System Wiring

The VP-X controls the trim motor as well as provides the circuitry to report the trim position to the EFIS. It also handles runaway or faulted trim conditions, and enables the EFIS to control the trim from the screen. All of the trim wiring is connected directly to the VP-X, and the trim position is reported to the EFIS over the serial data line.

The trim motor circuit breakers are set at 1 amp, and are not configurable.

Most experimental aircraft use trim servos from the Ray Allen Company (<http://www.rayallencompany.com>). These servos are self-contained units that include the trim motor as well as a position sensor. These servos are designed to run at 14 volts, and the VP-X Pro provides regulated 14v power to the trim motors so they can operate safely in 14v or 28v systems. The general principles described in this section apply to other brands of trim motor as well.

The Ray Allen trim servo (models B6-7T, B6-11T, T2-7A-TS, T2-10A-TS, or T3-12A-TS) has five 26 AWG wires, as shown in the diagram below:

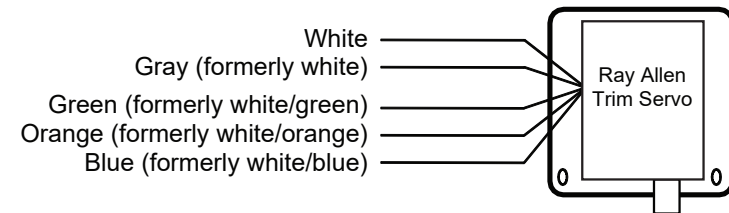

The trim motor itself is driven by a white and a gray wire (formerly two white wires). It does not matter how they are connected, as the polarity can be changed using the VP-X Configurator. The direction of travel is controlled by reversing the positive and negative connections to the trim motor. This is done conventionally using switches or relays, but is done in the VP-X with solid-state circuitry.

The position sensor connects with three wires – green (or white/green), orange (or white/orange), and blue (or white/blue). The three wires are wired directly to J1 on the VP-X.



Important:

Do not use the trim position inputs on the EFIS. The EFIS gets trim position information from the VP-X over the serial data line.

No external relays or switches are required between the trim servo and the VP-X.

You can wire trim switches for the pilot and, optionally, for the co-pilot. The trim switches must be momentary action so the trim motor runs only when the button or lever is pressed. You can use either an SPST momentary action button OFF-(ON) or an SPDT momentary action switch (ON)-OFF-(ON), with a middle OFF position.

Each trim axis requires two input pins: one to command trim in one direction, and one to command trim in the opposite direction. No external relays, modules, or indicator lights are required.

Ray Allen G205 and G207 stick grips should be wired per option 2 in the Ray Allen installation manual (shown in “Appendix F – Ray Allen Stick Grip Wiring” on page 80 in this manual.)

You may optionally wire a master trim disconnect switch in series between the VP-X and the trim motor.

The diagram shows the general wiring layout. It is repeated identically for both pitch and roll.

Wiring pilot trim switch only

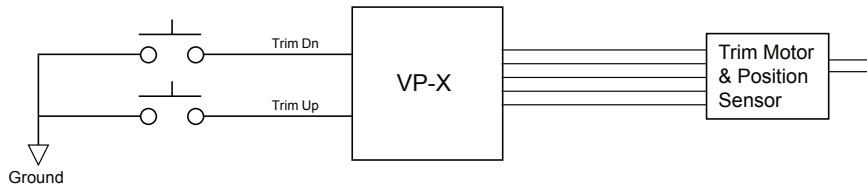

Wiring pilot and co-pilot trim switches

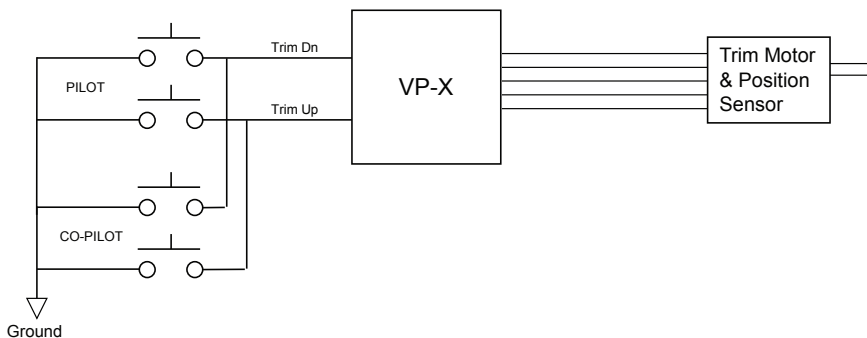

5.19a Pitch Trim Wiring

The trim wires are grouped together by trim function, and shown on the Load Planning worksheet. They are separated from each other by number, but are physically located next to each other on the connector. Each trim servo has five wires: two for motor power, and three for position feedback.

Pitch Trim

Function	VP-X Pin	I/O
+2.5 reference voltage (blue or white/blue)	J1-8	O
Ground (orange or white/orange)	J1-9	--
Position feedback (green or white/green)	J1-10	I
Trim motor (white)	J1-11 (connect either way)	O
Trim motor (gray, formerly white)	J1-12 (connect either way)	O
Pitch Trim Up switch input	J2-18	I
Pitch Trim Down switch input	J2-19	I

Connect the wires for the pitch trim system as follows, if installed:

- Run the 5-conductor wire (five wires bundles together) to the trim motor. The colors on the wiring harness match the colors on a Ray Allen sensor and can be connected color to color.
Note: in some aircraft, it is desirable to provide a connector near the elevator trim servo. A popular method is to crimp d-sub connector terminals (machined barrel, mil-spec) to the servo wires and to the wiring harness. First, slip a piece of large heat shrink tubing over the wiring harness and move aside for later. Then, connect the terminals on each wire pair and seal with heat shrink tubing, which insulates as well as provides a secure connection. Be sure to offset each terminal so that the bundle doesn't get too big. Cover the bundle of wires with the large heat shrink tubing.
- Connect the switch input pins to the trim switch (pilot and co-pilot). Connect the other side of the switch to ground.

5.19b Roll Trim Wiring

The trim wires are grouped together by trim function, and shown on the Load Planning worksheet. They are separated from each other by number, but are physically located next to each other on the connector. Each trim servo has five wires: two for motor power, and three for position feedback.

Roll Trim

Function	VP-X Pin	I/O
+2.5 reference voltage (blue or white/blue)	J1-3	O
Ground (orange or white/orange)	J1-4	--
Position feedback (green or white/green)	J1-5	I
Trim motor (white)	J1-6 (connect either way)	O
Trim motor (gray, formerly white)	J1-7 (connect either way)	O
Roll Trim Left switch input	J2-16	I
Roll Trim Right switch input	J2-17	I

Connect the wires for the roll trim system as follows, if installed:

- Run the 5-conductor wire (five wires bundled together) to the trim motor. The colors on the wiring harness match the colors on a Ray Allen sensor and can be connected color to color.
- Connect the switch input pins to the trim switch (pilot and co-pilot). Connect the other side of the switch to ground.

5.19c TruTrak Auto Trim Module

Follow the diagram below if installing the TruTrak auto trim module. The diagram is for both 14 volt and 28 volt systems.

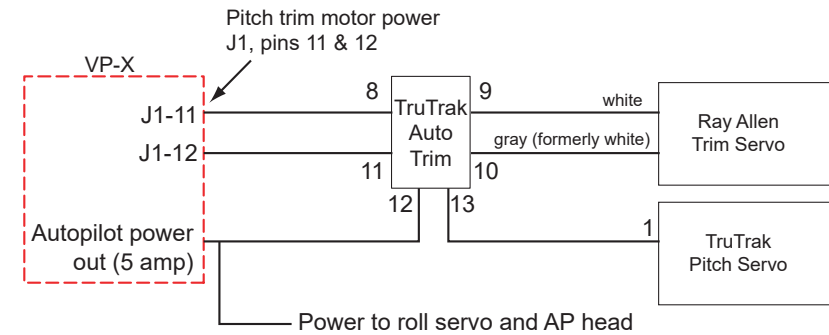

VP-X controls pitch trim when AP is off, TT auto trim controls pitch trim when AP is ON.

*TruTrak Auto Trim Module Wiring 14 & 28 volt
Other connections on each device not shown.*

5.19d Co-Pilot Disconnect Switch

A co-pilot disconnect function can be implemented by installing a switch to disconnect the common ground wire to the co-pilot stick.

5.19e Wiring a third trim motor

If you want to control a third trim motor, you can wire the third motor in a conventional manner and source circuit-protected power from one of the VP-X power pins (set circuit breaker value to 1A for this circuit). The diagram below shows a generic implementation, or you can use the switch and wiring diagram provided by Ray Allen Company.

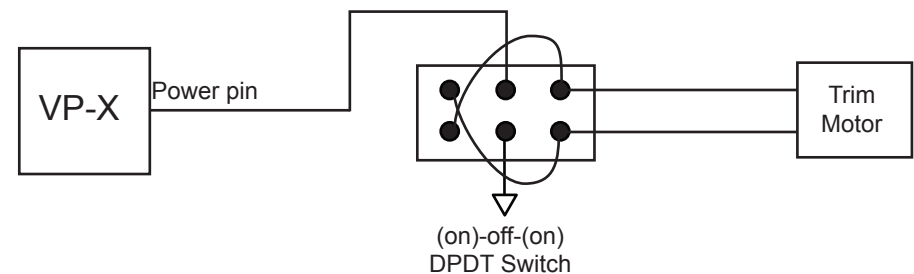

Note the above diagram is for a single switch. The complexity increases if you want to wire a pilot and co-pilot switch as well. In deciding which axis to wire using this method, we recommend considering the following:

- There is no third-axis position indicator with the VP-X.
- You have only one switch to control this axis to keep wiring simple
- There is no backup control from the EFIS for this axis

5.19f PH Aviation Trim

Contact Vertical Power Support for the latest information on using the VP-X with PH Aviation Trim.

5.19g Garmin GSA 28 With Auto-Trim

The diagram below shows how to install the Garmin G3X system with one or two GSA 28 autopilot servos. These servos also include auto trim functionality. Repeat this wiring for the pitch and roll servo. If you have a third yaw servo, that is wired outside the VP-X as shown in the Garmin manual.

Be sure to turn off the variable speed trim function on the VP-X unit as this functionality is included in the G3X system. Using the VP-X Configurator (later, when you get to the configuration section), go to **Pitch Trim Configuration** section, then set the **Speed** setting to 0.

Note Not all wiring to complete each module is shown. Consult the respective installation manuals for complete details on other wiring.

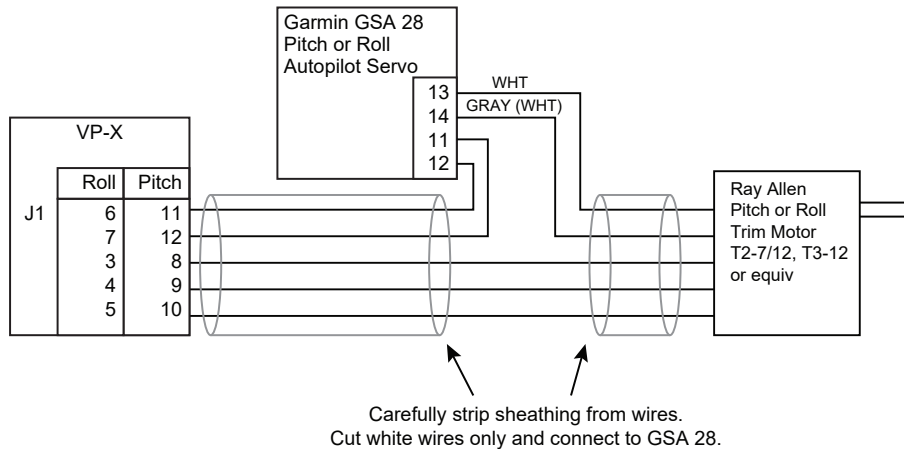

Turn off variable speed trim on VP-X.
 Details for non-white wires in VP-X Install Manual.
 Orientation of white/gray (or white/white) wires does not matter to VP-X, and can be changed using the configurator.
 Consult Garmin manual for correct orientation of white wires between GSA 28 and trim motor.

Wiring GSA 28 Servos to the VP-X.

5.19h Trio Auto Trim Module

Follow the diagram below if installing the Trio auto trim module. The diagram is for both 14 volt and 28 volt systems.

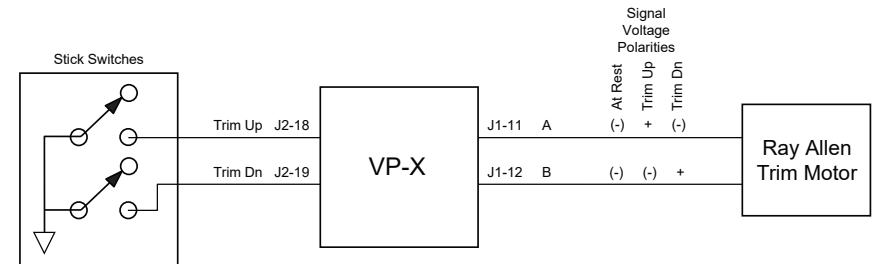

*Trio Auto Trim Module Wiring 14 & 28 volt
 Other connections on each device not shown.*

5.20 Flap System Wiring

The VP-X controls the flaps and provides circuitry for the flap position sensor. The flaps can be configured to run either:

1. Momentary – flaps only run when the flap switch is pressed. A position sensor is optional.
2. Position – flaps run down to the next position when the flap switch is pressed. Flaps run all the way up when the flap switch is pressed. The Van's Aircraft PA-12 flap motor OR a flap position sensor (Ray Allen POS-12) is required for this option. You can set 4 positions – a top, two middle (optional), and a bottom. When you press the flap up switch, the flaps go all the way up unless you press the flap down switch to stop them mid-stream. On some aircraft, you can set the reflex position to the top position, the 0 deg position to the first stop, approach flaps to the second stop, and landing flaps to the bottom stop.

If you are setting the flap circuit breaker value to greater than 5 amps, you must have a VP-X with serial number 1350 or higher – Contact Vertical Power Support if you need an upgrade.

As of firmware version 1.5 the VP-X also supports RV-10 reflex settings. In order to use the reflex settings you must have the flaps in Position mode as described above. No special wiring is required to use the reflex features. See “10.5 Trim and flap operation” on page 68 for details on reflex operation.

Flap Position Sensor (optional)

Function	Wire Colors		VP-X Pin	I/O
	Van's PA-12	Ray Allen		
Position feedback	Red	Green or white/green	J1-17	I
Ground	White	Orange or white/orange	J1-18	--
Reference voltage*	Yellow	Blue or white/blue	J1-19	O

*VP-X works with both Van's +5 VDC and Ray Allen +2.5 VDC reference voltages

Flap Motor and Switch Inputs

Function	VP-X Pin	I/O
Flap motor**	J12-5 (connect either way)	O
Flap motor**	J12-6 (connect either way)	O
Flap Up switch input	J2-14	I
Flap Down switch input	J2-15	I

**Blue or Brown wire from Van's PA-12

You can wire a flap switch for the pilot and, optionally, one for the co-pilot. The flap switch must be an SPDT momentary action switch (ON)-OFF-(ON), with a middle OFF position. Many flap switches also come as DPDT switches. If you have a DPDT switch, you can wire it as shown in the diagram below:

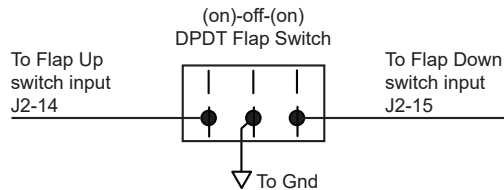

Only three terminals on one side of the switch need to be used. (Switch viewed from back)

Do not install a flap switch that stays in the UP position.

The flap switch has three pins: a common, one to command flaps up and one to command flaps down.

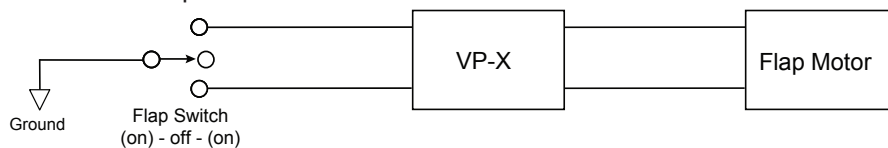

Both flap motor pins on the VP-X (J12, pins 5 & 6) are wired directly to the flap motor. The polarity of the wires does not matter, as it can be reversed in the setup menus.

RV flap system: Do not install the Van's Flap Positioning System (FPS).

If you want intermediate stops or flap position feedback on the EFIS, either use the Van's PA-12 flap motor or install a Ray Allen POS-12 position sensor.

Using the Ray Allen POS-12:



Ray Allen Flap Position Sensor

You can purchase a clevis/pushrod kit from your local hobby shop, as the Ray Allen kit is not for use with the POS-12.

Where to mount the POS-12:

The POS-12 should be mounted so that a pushrod can be attached to both the POS-12 and to the bell crank on the flap system. The pushrod should be mounted a certain distance away from its center of rotation so that the position sensor arm moves 1 inch as the flaps move through their entire range of travel. This distance can be found through trial and error.

Wiring the flap system

The flap motor is powered through the J12 power connector, and the position feedback is connected through the J1 d-sub connector. Connect the flaps as follows:

- Connect J12 Pins 5 & 6 to the flap motor. Each pin goes to one of the two wires on the flap motor. The polarity does not matter and can be changed using the setup menus.
- If using the Van's PA-12 or installing a linear flap position sensor, connect J1 Pins 17, 18, 19 to the sensor. The colors on the wiring harness match the colors on a Ray Allen sensor and can be connected color to color. If you are not using a Ray Allen sensor, the function of each wire is detailed in the table above.
- Connect J2 pins 14 & 15 to flap switch or switches. Connect the common terminal on the switch to ground.

	<p>Important:</p> <p>Do not use the flap position inputs on the EFIS. The EFIS gets flap position information from the VP-X over the serial data line.</p> <p>Do not install any third-party flap controller module.</p>
--	---

5.20a Flaps System With Limit Switches

Some aircraft like the Lancair Legacy use limit switches to stop the flap motor at the travel limits. The VP-X does not support the use of these switches directly. You must therefore wire the flap system outside of the VP-X and use the VP-X simply to provide power to the flap system. There is a workaround that may or may not be acceptable to you that is described below.

Use a 10A power pin to provide circuit-protected power and wire the flap switch, flap motor and flap motor limit switches per the wiring diagram provided by the airframe manufacturer. The flap motor power wires on J12 and flap switch inputs on J2 are not used.

A flap position sensor can be installed and wired as described above (to show flap position on the EFIS).

There is a way to use the VP-X with flap systems that require limit switches, but comes with some risk and trade-offs. We will describe those trade-offs and leave it to you to determine if that is acceptable or not. In this case, you can use the position sensor instead of the limit switches to stop the flap motor. The VP-X stops the flap motor at pre-defined stops when configured as “position” (vs. “momentary”). During configuration, be sure to set the “End Duration” value to zero or a very low value to minimize run-on. The risks are:

1. There is inherently more slop in the position sensor than the limit switches, so the flaps may not stop at the exact point you want them to every time.
2. If the position sensor fails, the VP-X may not stop the flap motor and the motor may run past the defined limits and may cause physical damage to the airframe and/or flap system.
3. When you run the flaps from the EFIS the position sensor limits are ignored so it is possible that the flaps can be run past their normal limits.

5.21 Panel Switches Wiring

The VP-X turns power pins on and off based on external switches. Each switch is wired to a discrete input on the VP-X and to ground. When the switch is closed, it grounds the input pin on the VP-X, signaling the VP-X to turn on the power pins that are assigned to that switch. You can have any number of power pins associated with a switch. For example, a switch can be labeled “Avionics Master” and then all the power pins wired to the avionics can be assigned to that switch. Another switch can be labeled “Strobe Light” and the power pin going to the strobe light can be associated with that switch.

The VP-X performs the actual switching function. There is almost NO current going through the panel switches. Therefore, you can use any type and style of switch that you like.

The table below shows the switch inputs and the associated pin.

Function	VP-X Pin	I/O
Switch 1 Input	J2-1	I
Switch 2 Input	J2-2	I
Switch 3 Input	J2-3	I
Switch 4 Input	J2-4	I
Switch 5 Input	J2-5	I
Switch 6 Input	J2-6	I
Switch 7 Input	J2-7	I
Switch 8 Input	J2-8	I
Switch 9 Input	J2-9	I
Switch 10 Input	J2-10	I

5.21a Standard switches

The diagram below shows how to wire a switch or group of switches. While there are ten switch inputs, you can use only the inputs that you need and leave the unused inputs unconnected.

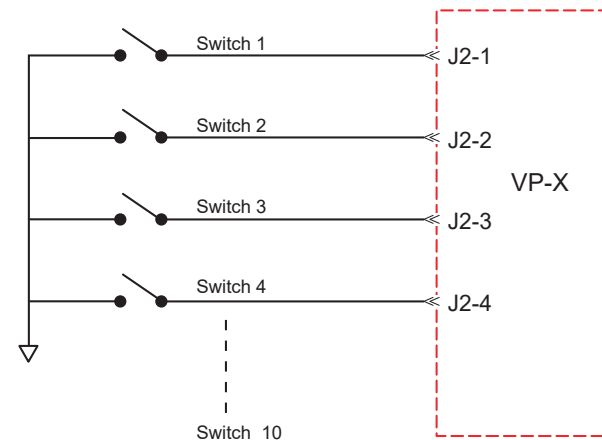

- Wire each switch to an input on the VP-X.
- Wire the other terminal on each switch to ground. Use the same ground block as the VP-X ground wiring.

5.21b Wiring lighted switches

Lighted switches can be used with the VP-X but certain factors must be considered. Lighted switches are designed in many different ways.

A common design has three terminals on the back, and the switch must be used on the powered side of a circuit. The switch uses the power it is switching to also power the light in the switch. This will not work with the VP-X as the VP-X switch inputs require ground and not power.

A switch that works with the VP-X has the lighting circuit separate from the switching circuit. When you turn on (close) the switch, it provides a ground to the VP-X switch input and also provides a ground to the light on the switch, causing it to turn on. The diagram below shows how to wire a lighted switch:

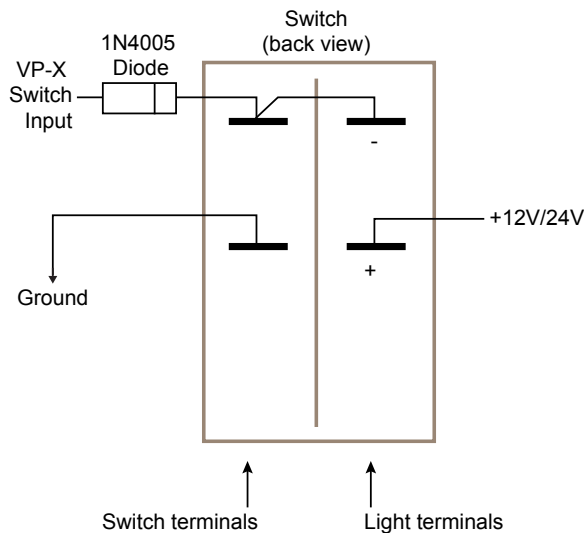

A diode must be placed on each switch input to the VP-X.

Most switches are part of a “family” and a specific style comes in multiple configurations. Therefore, if the switch you like does not work with the VP-X, look at the manufacturer’s catalog and see if they make another similar switch that does work. Because of the wide variety of switches that are available, we recommend testing a single switch first before cutting your instrument panel.

5.21c Alternator switch

If installing a single alternator, the alternator switch can be a simple on/off switch (SPST) wired to one of the inputs. You then associate (in the setup menus) the Primary Alternator pin (J12-11) with that switch input.

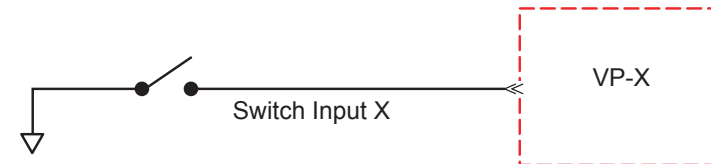

Single Alternator Switch Inputs

If installing primary and backup alternators, you should use a switch that mechanically allows either one to be on, but not both at the same time, and has a center off position. We recommend a SPDT or DPDT ON-OFF-ON switch for this purpose. The VP-X does not allow both alternators to run simultaneously.

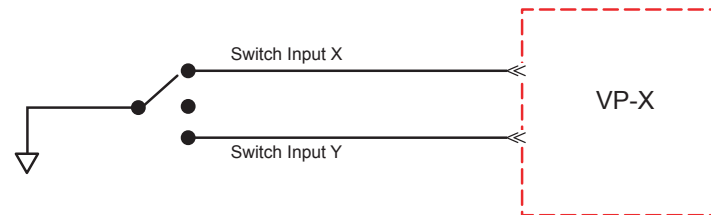

Dual Alternator Switch Inputs

In the designs above, when you turn off the master switch the alternator stays running and may still provide power to the bus. You need to manually turn off the alternator switch as well to shut off all power.

In the designs below, shutting off the master switch turns off both the battery contactor and the alternator. This shuts off all electrical power with one single switch (except for backup circuits and backup batteries as described elsewhere in this manual).

How it works: When the master switch is turned on, one pole of the switch provides a ground to the battery contactor (which closes) and the other pole provides a ground to the alternator switch. When the alternator switch is turned on it grounds the alternator switch input pin which then turns on the alternator. Turning off the master removes the ground from the battery contactor and from the alternator switch which then causes the VP-X to turn off the alternator.

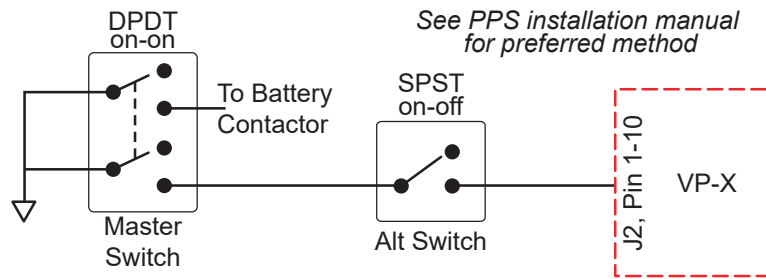

Wiring for single alternator

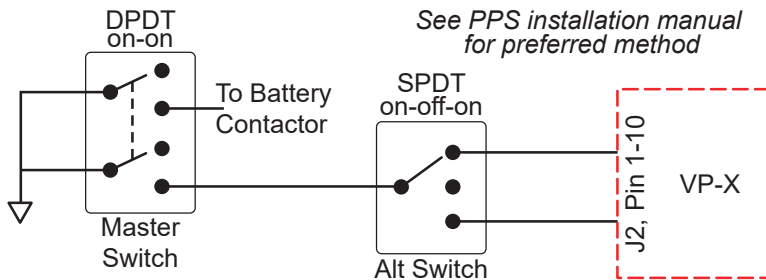

Wiring for dual alternators

- Wire the alternator switch(es).

5.21d Boost pump switch

If installing a single-speed boost pump (for most Lycoming, Jabiru, and Rotax engines), the boost pump switch can be a simple on/off switch (SPST) wired to one of the inputs. You then associate (in the setup menus) the boost pump power pin with that switch input.

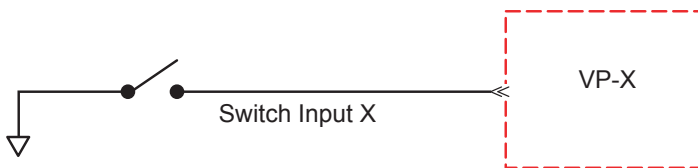

Single-Speed Boost Pump Switch Input

If installing a two-speed boost pump (commonly used on Continental engines), use a switch that mechanically allows either one to be on, but not both at the same time, and has a center off position (SPDT ON-OFF-ON). A locking toggle switch is recommended so that the high boost does not accidentally turn on in flight. A DUAL SPEED BOOST PUMP MUST BE WIRED AS SHOWN BELOW:

Use a single power pin set to “always on” and then wire the switch in-line between the VP-X and the boost pump. The switch does have to be rated to carry the current load of the pump.

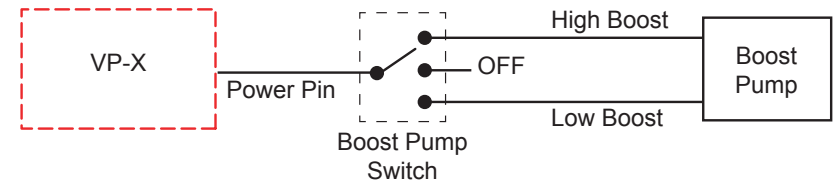

Dual-Speed Boost Pump Wiring

- Wire the boost pump switch.

5.21e Dual-Function Switch

Sometimes you’ll want to wire a switch where the bottom position turns on a device, the middle is off, and the top position turns on two devices. An example is a switch that turns on nav and strobe lights. The example shown here demonstrates the basic idea and you can modify this as needed for your particular application.

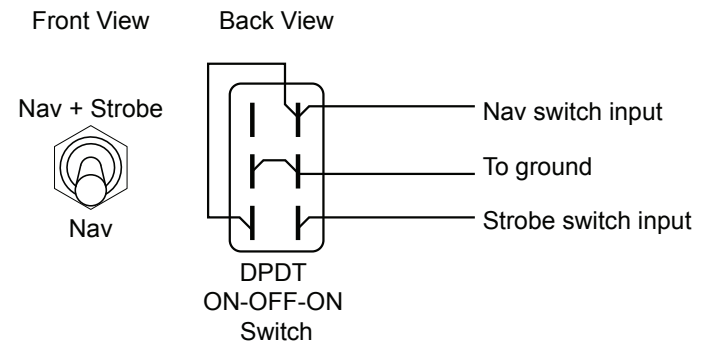

Wiring a Dual-Function Switch

5.21f Dimmer wiring

Wire the dimmer in-line between the VP-X and the device, such as a load. Ensure the rheostat is sized appropriately for the electrical load.

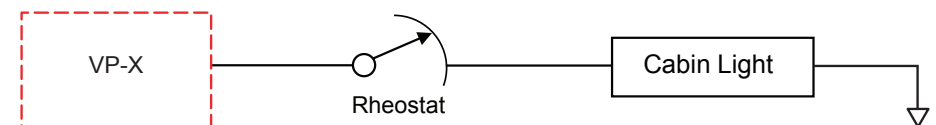

5.21g Mag switch wiring

The mag switch, which is wired to the p-lead on the magneto or electronic ignition, is separate from the VP-X. Follow the ignition manufacturer's instructions for wiring.

- Wire the mag switch.

5.22 P-Mag wiring

The p-leads (pin 4) on the P-Mag are wired to the mag switch, allowing you to disable the ignition as part of the run up checks. You may also want to disconnect power individually to each p-mag to test the power-off operation during run-up (you are testing the unit's ability to generate its own power). Wire the P-Mag to one of the power connectors and set the circuit breaker value to 3 amps. (Yes, the P-Mag manual says to use a 2 amp circuit breaker but there are some cases that drive the need for a 3 amp circuit breaker).

There are three options to power the p-mag(s). The examples below show dual P-Mags but the same wiring applies to a single P-Mag installation. Wire power to the P-Mags using one of the three examples below:

1. Wire the power directly from the VP-X to the p-mags. Set the pin on the VP-X to "Always On" (using the configurator on your laptop). Use the VP-X page on the EFIS to turn power off then back on to this circuit when you are testing the P-Mag. The EFIS allows you to turn power on and off to devices individually right from the screen, and is primarily meant to be used as a backup to the regular switches.

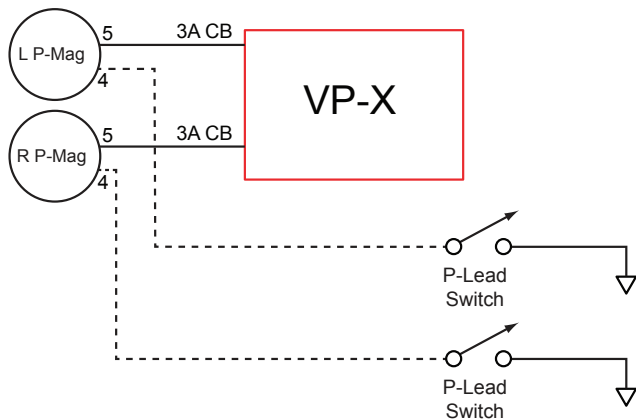

2. Wire the power to the p-mags, installing a switch in between the p-mags and the VP-X. Set the pin on the VP-X to "Always On" (using the configurator on your laptop).

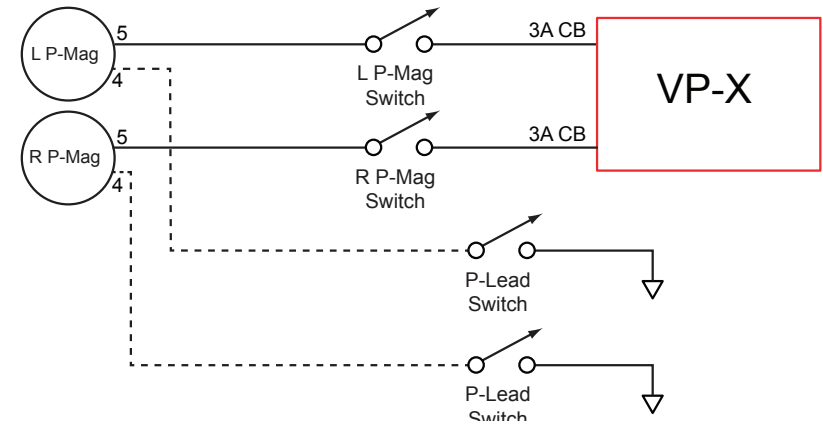

3. Wire power to the P-Mag using a direct power connection and controlling it via a standard switch wired to a switch input.

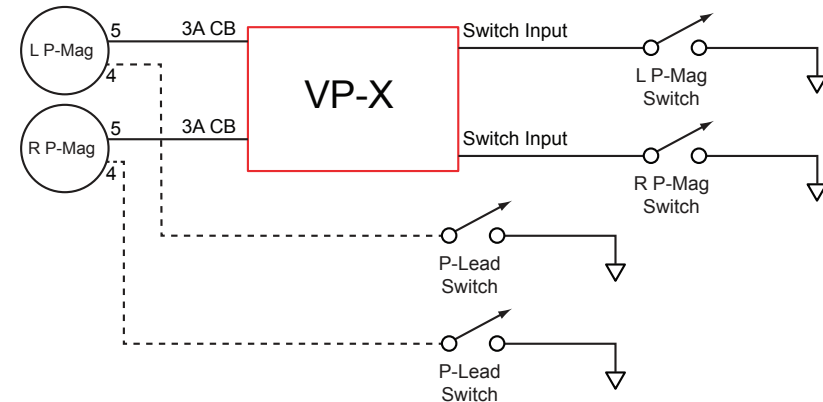

5.23 Lightspeed Ignition wiring

If you are wiring a single LSE ignition system (with a magneto on the other side), we recommend wiring the LSE power wire directly to the VP-X and the ground wire to ground.

If you are wiring a dual LSE ignition system, we recommend using two batteries and wiring each ignition directly from each battery, similar to the method suggested in the LSE installation manual. Please see the section in this manual "Dual Battery/Single Bus Wiring."

5.24 Planning and Wiring Backup Circuits

Backup circuits allow you to wire backup power directly from the battery, through an external fuse and switch (separate from the VP-X), and then to the device. Each circuit can provide backup power to a device regardless of whether the VP-X is on or off.

Remember, as the aircraft builder, you are the systems engineer for the electrical system design. So it is important to design the systems to support the type of mission you expect to fly. Just because a friend built his plane a certain way does not mean it is necessarily the right way for you to build your plane. With that in mind, our goal here is to provide the information you need to design a backup system that is right for you.

Take for example the EFIS. It's important to consider what happens when it fails. There's nothing you can do to prevent it from failing at some point in the future, but you can mitigate the risk when it does fail. You do that by installing a separate backup EFIS with limited capability but one that can get you back on the ground safely.

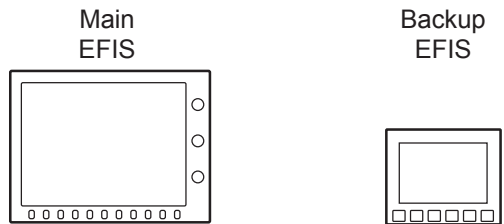

Even if a single EFIS fails, the overall system is very safe and reliable.

The same analogy applies to the electrical system. The VP-X is the main power distribution mechanism and you can also install backup circuits for certain critical avionics. In the same way that your backup EFIS has minimal functionality to ensure safety for the mission at hand, the backup circuits are selected to support the essential equipment you need to continue flight safely.

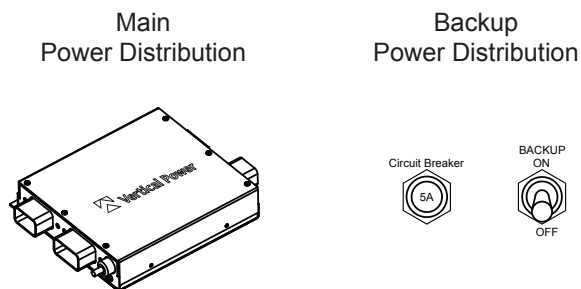

Even if a single component fails, the overall system is very safe and reliable.

5.24a Backup Circuit Considerations

There is a great deal of subjective decision making that goes into determining the number of backup circuits to wire. Backups are not uncommon in other systems on the aircraft. For example, the old vacuum-drive attitude indicator had an electric turn and bank instrument for backup. A modern glass EFIS is often installed with backup altitude, attitude, and airspeed round-dial gauges. You have two magnetos for redundancy, and if one fails in flight you can safely land at a nearby airport. But, if one fails on the ground you would not likely takeoff with only one operating.

On one hand, backup circuits add more redundancy, but on the other add more complexity and failure points. Ultimately, you as the builder should do what you are most comfortable with based on your mission and aircraft. Here we will provide a few data points to help in your thinking and planning. They are not absolute or regulatory, only suggestions for thought.

There are two types of failures to consider. One type of failure occurs on the ground and prevents you from flying. The other type of failure occurs while you are flying and may be harmless or could require you land at the next opportunity.

With regard to failures on the ground that keep you from flying: there are many single-points of failure that exist on aircraft today. Would you start the engine or take off if any of the following conditions existed:

- Failed EFIS, AHRS, or engine monitor?
- Failed ignition or magneto?
- Leaky brake o-ring or tire inner tube?
- Starter failure causing you to hand-prop the engine?
- Failed alternator or battery contactor?

The point is there are many single points of failure that can keep you from flying, and the safest thing to do is fix the problem while you are on the ground. It's common sense to always have a Plan B if your plane breaks while you are away from home. With that in mind, the VP-X should not be thought of any differently than any other component that may ground you if it fails. While you can wire backups for the alternator field, for example, to get you home, it may be overkill considering that there are many other components on the plane that are likely to ground you as well. Do you have two sets of engine instruments installed, including dual sensors for everything?

The other failure mode occurs when you are in flight. Perhaps the most critical is a backup for the attitude source. The others will depend on your mission and whether you carry a backup comm radio and/or backup GPS

receiver. If you fly only VFR or have battery backups built into the EFIS system, then backup wiring may not be necessary. If you fly IFR, then critical circuits should be protected by backups.

There are two different methods to wire backup circuits (simply called Method B or C).

5.24b Backup Method B

Backup capability is the ability to provide power to an electrical device independent of the switching internal to the VP-X.

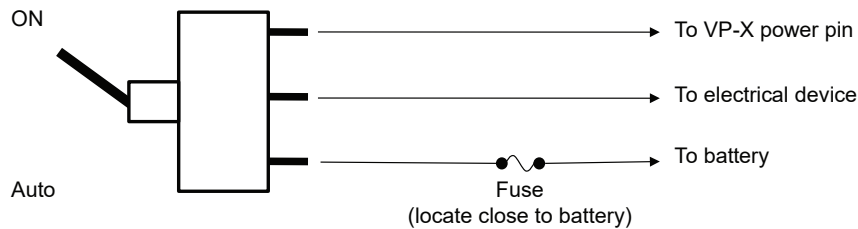

How it works: the switch is normally left in the Auto position, which provides switched power from the VP-X to the electrical device. When the switch is moved to the ON position, uninterrupted power is provided directly from the battery to the electrical device. Make sure the switch and fuse are appropriately rated for the load and wire size. **When battery power is switched on, there is a break in circuit continuity. Whether this causes the connected device to reboot is a function of the switch design and device design.** We recommend testing this on the bench. Certain devices like boost pump and lighting can cycle power without issue.

Example: You want to add backup capability to the boost pump, which in this example requires a 10A circuit. Wire the boost pump to a 10A circuit on the VP-X via a switch as shown above, and bring in a wire with a 10A fuse directly from the battery.

If you are wiring a backup circuit for an alternator, be sure the alternator or voltage regulator has built-in over-voltage protection. The backup circuit bypasses the OV protection built into the VP-X.

Below is an example of two backup circuits wired to two different devices. Note that each backup circuit has its own fuse, and that the fuse matches the value of the electronic circuit breaker set in the VP-X.

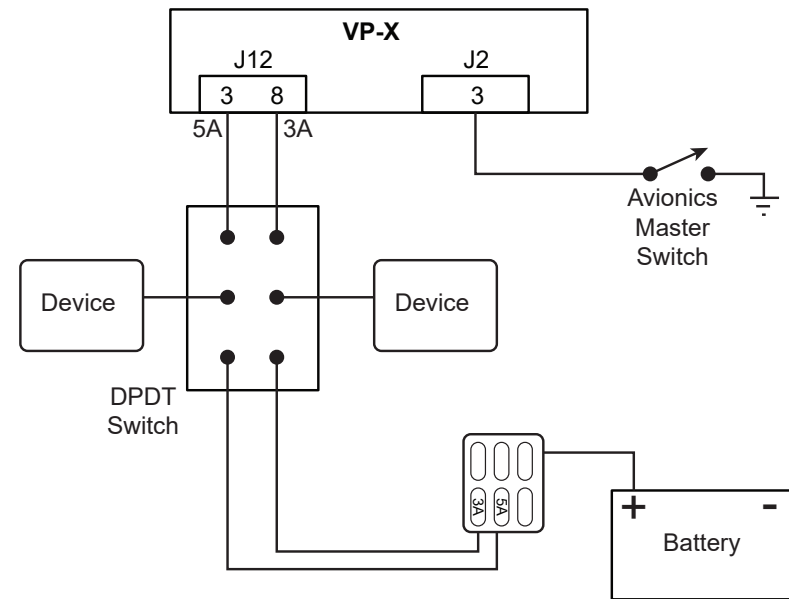

Example backup Method B circuit with two devices.

5.24c Backup Method C

Many modern EFISs have multiple, diode-isolated power inputs – typically a primary and a secondary power input. The diode isolation ensures that each power input is “independent” of the other power inputs. Method C allows you to wire a backup circuit into the secondary power input on the EFIS (or other device if that is the case) directly from the battery through a fuse and a switch. The EFIS will automatically choose between the inputs and select the one with the highest voltage.

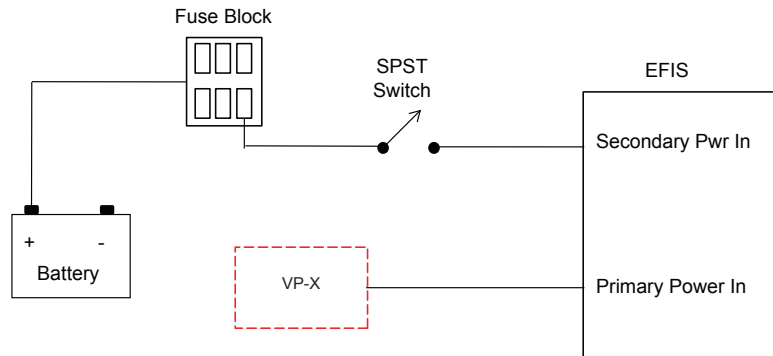

Wire a fuse or fuse block near the battery. Size the fuse for the wires and as per recommended by the EFIS manufacturer. Then wire to an SPST switch. The switch should be labeled ‘VP-X’ (down) and ‘Backup’ or ‘BU’ (up). When the switch is down (VP-X position), power will be sourced from the VP-X. When the switch is up (BU position), power will be sourced directly from the backup battery bus.

Below is an example of a two backup circuit wired to two different devices. Note that each backup circuit has its own fuse, and that the fuse matches the value of the electronic circuit breaker set in the VP-X.

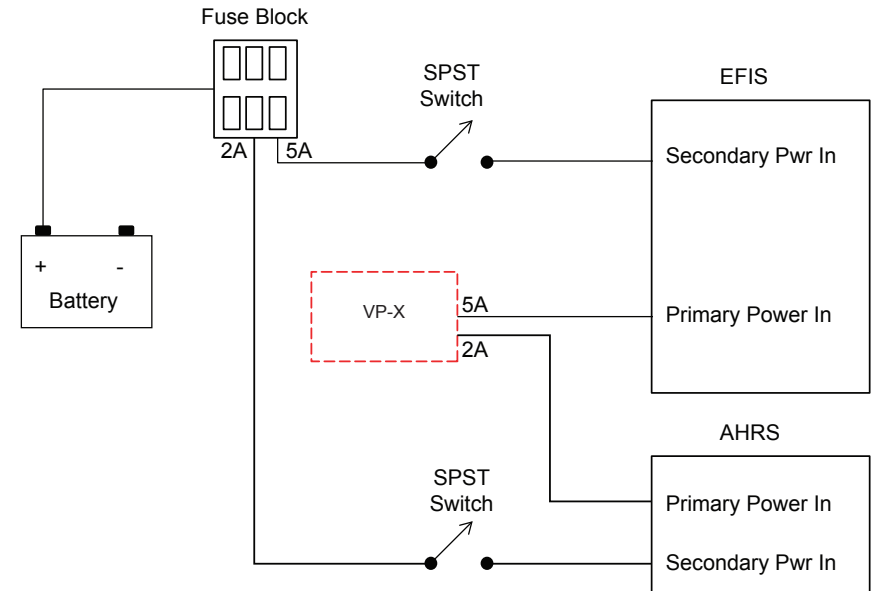

Example backup Method C circuit with two devices.

5.24d Do not wire backups this way

Do not wire other circuits so that battery power is provided directly to the device, as illustrated in the diagram below.

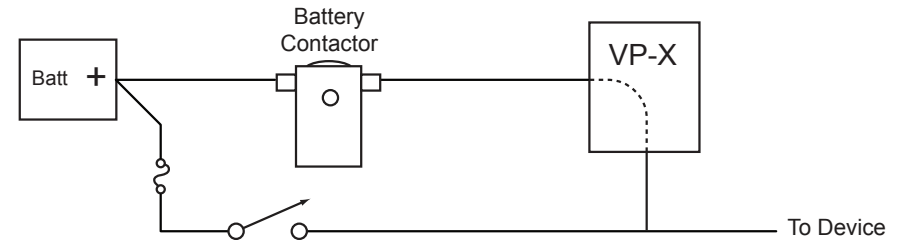

Do NOT wire backups directly to power output of VP-X.

Doing so may cause unreliable operation and may blow the fuse under certain circumstances.

5.24e Aft-mounted battery considerations

If the battery in your aircraft is mounted in the aft section of the aircraft, you must take special care to route the backup switch wiring because the routing is longer than for front mounted batteries. You may want to consider running a slightly larger wire to account for the additional length. FAA AC 43.13-1B includes a chart (figure 11-2) to determine the wire size.

Another consideration is that the relatively long length of wire must be protected from short circuits. There are two options to choose from:

1. Run each backup wire to the back, and to an individual fuse in a fuse block. Have a fuse block in back with a short wire (perhaps 12ga) to the battery. You don't need to protect the 12ga wire because it is so short. If a wire running to the front shorts, you lose just that circuit.
2. Run a larger wire from the back to the front. Install a larger fuse in the back to protect the long run to the front, then smaller fuses in the fuse block up front for each backup circuit. However, if the larger fuse blows all the backups fail in one shot.

Keep in mind these are backup circuits and normally only used when the primary switching method fails. Choose the option that works best for your mission and personal assessment of merits of each.

The diagram below shows the relative layout of the backup circuit components. Note that the fuses (or breakers) are in the back near the battery, providing protection for the wire run forward.

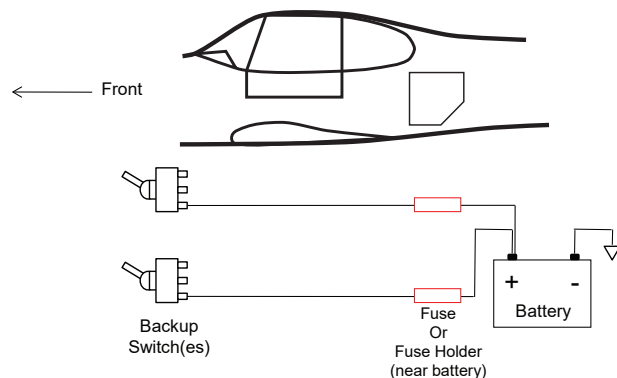

5.25 TCW Integrated Back-Up Battery System

The TCW Integrated Back-Up Battery System (IBBS) can be used with the VP-X. Section 5.25a applies to 2/4ah wiring and Section 5.25b applies to 3/6ah wiring.

5.25a TCW IBBS 2/4ah Wiring

There are two ways to wire the TCW IBBS 2/4ah, depending on if the protected device has one or two power inputs.

Pin 1 is used to charge the internal IBBS battery.

Pin 6 is used as a power source for the device wired to pins 7, 8, or 9.

If the device has a single power input like a TruTrak Gemini or Garmin 430/530/650/750 then use option 1.

If the device has dual power inputs, then use option 2.

Option 1:

This method wires the IBBS charge circuit and the circuit that carries the device load (the device that is getting backup power like an EFIS or radio) separately from two separate pins on the VP-X. In this manner the load circuit can be protected separately from the charge circuit. Wire pin 1 and pin 6 from the IBBS into separate power pins on the VP-X. Set the circuit breaker value for the circuit that goes to pin 1 on the IBBS to 5 amps, and set the circuit breaker value for the wire that goes to pin 6 to the value recommended by the device manufacturer.

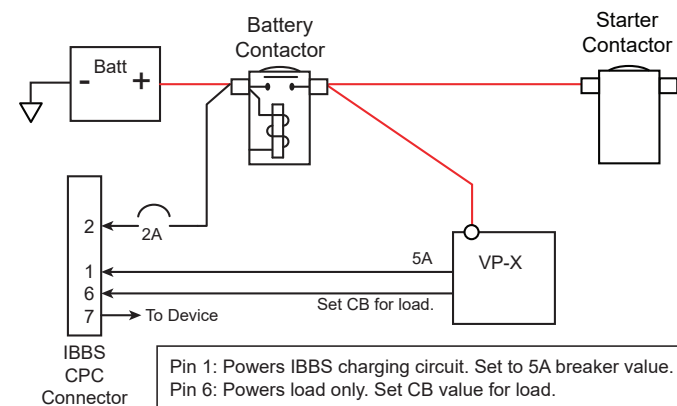

Option 2:

This method uses the IBBS solely as a backup power supply to a device that has dual power inputs (like most EFIS displays).

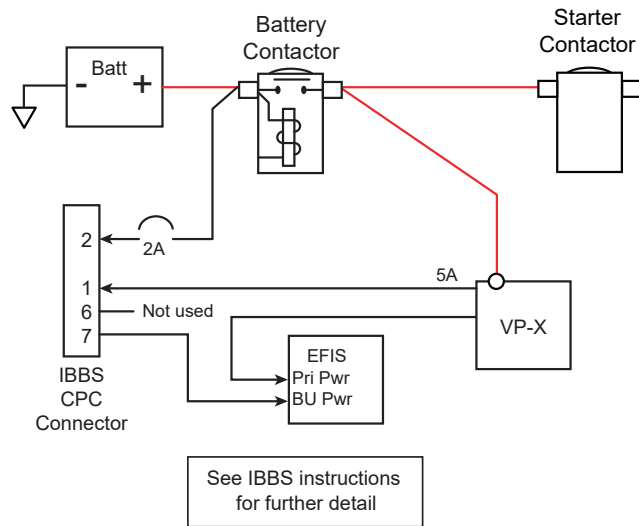

Notes	Locate the 2A fuse as close to the source of power as possible.
	The other pinouts on the IBBS are shown in the TCW IBBS installation manual. Only the power inputs are shown here for clarity.

5.25b TCW IBBS 3/6ah Wiring

There are two ways to wire the TCW IBBS 3/6ah, depending on if the protected device has one or two power inputs.

Pin 5 is used to charge the internal IBBS battery.

Pin 6, 7, 8 are used as power source for the devices wired to pins 12-15.

If the device has a single power input use option 1.

If the device has dual power inputs use option 2.

Option 1:

This method wires the IBBS charge circuit and the circuit that carries the device load (the device that is getting backup power like an EFIS or radio) separately from two separate pins on the VP-X. In this manner the load circuit can be protected separately from the charge circuit. Wire pin 5 and pins 6, 7, 8 from the IBBS into separate power pins on the VP-X (pins 6, 7, 8 can use one VP-X pin to conserve outputs if the backed up devices fit within the CB limit). Set the circuit breaker value for the circuit that goes to pin 5 on the IBBS to 5 amps, and set the circuit breaker value(s) for the wire(s) that go to pins 6, 7, 8 to the value recommended by the device manufacturer.

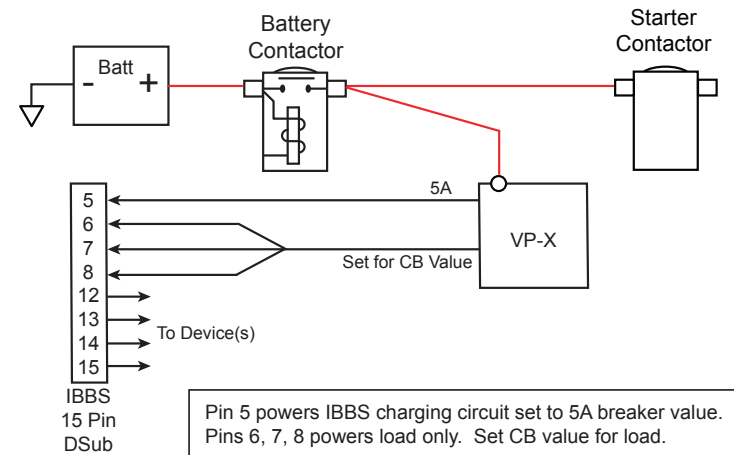

Option 2:

This method uses the IBBS solely as a backup power supply to a device that has dual power inputs (like most EFIS displays). Wire per the diagram and see IBBS instructions for further detail.

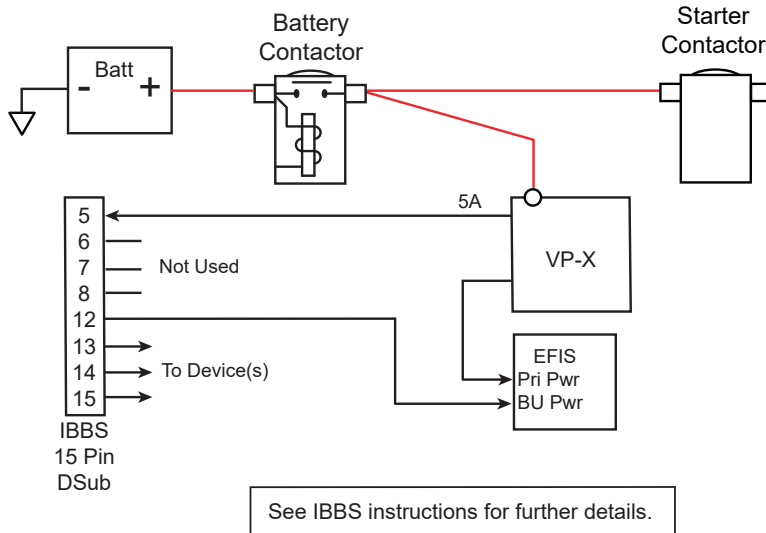

Note: The other pinouts on the IBBS are shown in the TCW IBBS installation manual. Only the power inputs are shown here for clarity.

5.26 Dual Battery/Single Bus Wiring

Note The Primary Power System (PPS) is a single battery unit only, so the following section applies to traditional systems only. The PPS is fully compatible with dual alternators.

Some installations require the use of a dual battery architecture. Commonly this is used for dual Lightspeed ignitions or engines with an electric ECU like a Viking, Subaru or Chevy. Sometimes an additional battery is used to keep the EFIS alive during start (Option 2 is the easiest way to wire for this scenario).

While there are many variables to consider, we generally recommend installing a backup alternator instead of a second battery if extending the length of time for backup power is a design goal. The main reason is that a backup alternator allows you to fly indefinitely (assuming the electrical load is less than the backup alternator capacity which is easy to do with modern

avionics) while a second battery only has limited endurance. While the backup alternator costs more initially than a second battery, it likely requires less ongoing maintenance (the aux battery should be replaced every two years) and better fits the stated goal of longer electrical system endurance in case of primary alternator failure.

There are several ways to wire an aux battery, depending on your application. You can install an aux battery contactor to connect or isolate the aux battery from the main bus. The aux battery can also be charged using a diode (this option should be used only when small switched loads are attached to the battery).

The VP-X works with either (or both) a backup alternator or a second battery, so the above is simply food for thought for you to apply to your specific situation and design goals.

Below are two possible ways to wire a second or AUX battery.

Option 1:

This provides a hard connection between the two batteries and allows the pilot to easily connect or disconnect the aux battery. Once the engine is running, the aux battery contactor is closed and the two batteries are essentially one large battery – both are charged by the alternator simultaneously. This option also allows the user to connect the two batteries together for start. Conversely, a backup circuit for the avionics can be connected to the aux battery and used to keep the EFIS from rebooting during start (the aux battery contactor is open in this scenario).

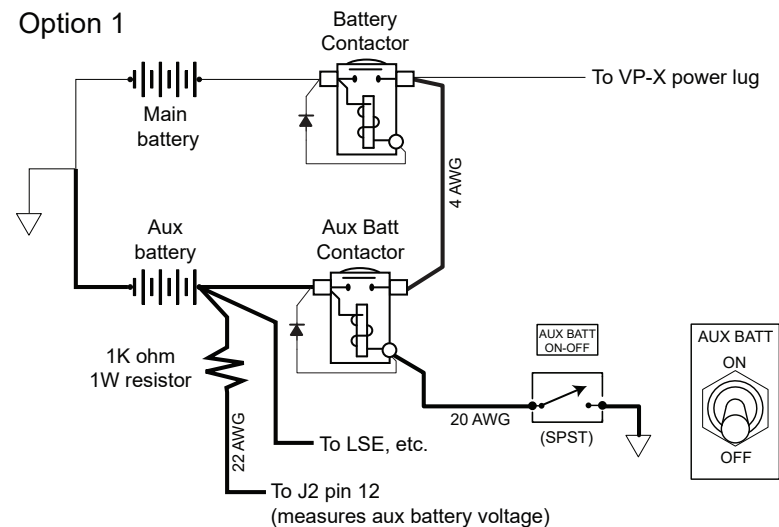

Option 2:

The diode is used to charge the aux battery when the master switch is on. The aux battery should only be used for minimal loads that won't exceed the maximum charge current; in this case 10 amps.

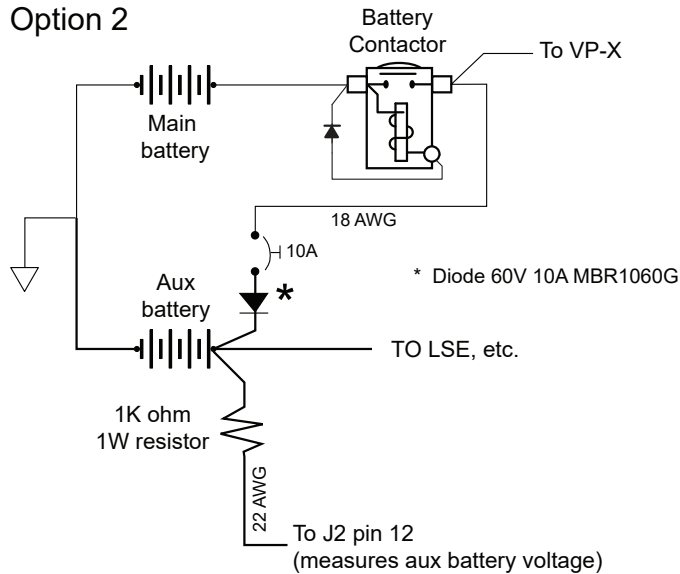

Be sure to fully charge batteries before installation and use!

5.27 Aux Battery Wiring and Voltage Measurement

This section applies to the **VP-X Pro** only.

Function	VP-X Pin	I/O
Aux battery voltage measurement	J2-12	I

This pin measures voltage and reports it to the EFIS for display. A resistor should be placed in-line near the aux battery to provide circuit protection for the wire.

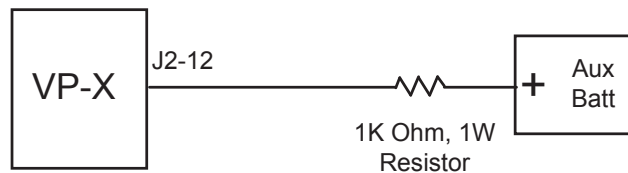

- Install a 20 or 22 AWG wire from J2-12 to the aux battery positive terminal. Install a 1K Ohm, 1 watt resistor in-line near the battery.

TIP

Wiring Tip: The resistor is a weak spot in the wiring. The resistor itself is fragile, as is the small lead on either side of the resistor. To create a more secure joint, use the wire itself as a reinforcement. Solder the resistor leads onto the wire as shown below, keeping the resistor leads as short as possible. After soldering, cover the assembly with heat shrink to keep it securely held together.

Solder (2x)

Heat Shrink Tubing

Slide

5.28 AeroLEDs Wiring

AeroLEDs recommends using shielded power wire for certain lights (AeroLED makes a “linear” voltage light that does not require shielded cable). If you need the power connector terminals crimped on the shielded wire, please send us the wire (strip and prepare shielding on the terminal end prior to sending) and we will crimp the terminals on for you.

Please follow the latest AeroLEDs instructions with regard to shielding and case grounding. Please see Appendix E in this manual for detailed information regarding wiring AeroLEDs.

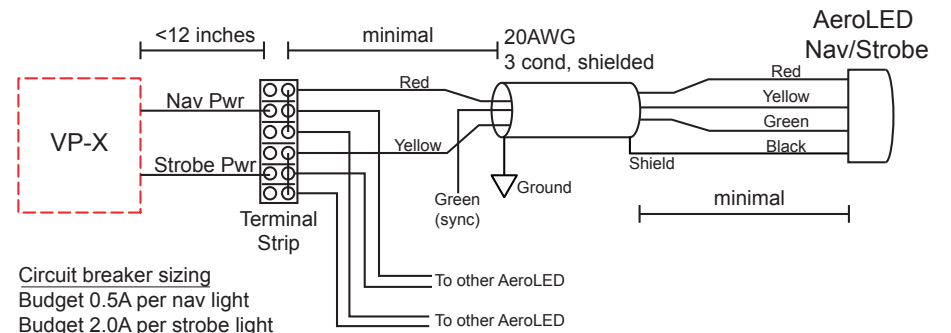

5.29 Strobe Light (non-LED) Wiring

The VP-X provides power to the strobe power supply, which in turn provides high-voltage to the strobe lights at the wing tips. Follow the strobe light manufacturer's instructions for installation and circuit breaker sizing. The diagram below shows a generic installation.

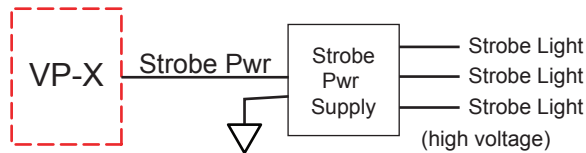

5.30 Retractable Gear Wiring

The VP-X provides a source of circuit protected power for the gear switch. Wire the gear system per the airframe manufacturer's instructions.

5.31 Testing Individual Circuits

At this point, all the power wires should be connected to their respective devices. The purpose of this step is to verify correct installation of the wiring.

Taking your time and being methodical on this step will save troubleshooting time later.

Make sure that the following bulleted items are carefully checked prior to proceeding.

- Disconnect the large wire going to the starter to eliminate any chance that the starter may be accidentally engaged. Temporarily cover the exposed end of the wire with electrical tape.
- Make sure that the propeller area is clear and can rotate freely.
- Verify that the fuel system is sealed or empty.
- Verify that the area around and under the flaps is clear.
- Verify that the area around the trim motors and tabs is clear.
- Verify the high-voltage strobe wiring is either sealed or connected to a strobe light.

- Check for any other conditions that may be problematic during testing.

When I measure a pin that is “off” with a digital multimeter, I get a voltage reading. Is this normal?

Solid-state switches have a characteristic called stray or phantom voltage that will read slightly below bus voltage on a power pin even when that pin is off. Don't worry, it won't cause sparks or arcing. There is no “power” behind the voltage, it is simply an artifact of the solid-state switches (a specialized transistor). In order to measure voltage correctly, there needs to be a load on the pin, like a test lamp, when taking measurements. If the pin is off, the voltage will be zero when there is a load on it. If the pin is on it will read at bus voltage when there is a load on it.

Then proceed with the following steps:

- Turn off the master switch.
- Disconnect the wiring harness connectors from J1, J2, J8, J10, J12 on the VP-X.
- Verify that the correct wire is in the correct connector location using the Load Planning worksheet as a reference.
- Prepare test leads for the d-sub connector using two 20 or 22 gauge wires about 10ft long each with a female d-sub connector terminal crimped on one end and an in-line 2A fuse on the other.
- Prepare test leads for the power connectors using the test leads in the wiring harness kit, attach spade terminals to an appropriately rated blade fuse and then to the battery or hot wire. Using a bare-end wire, paperclip or screwdriver rather than the male terminal on the test lead may damage the gold coating on the terminals inside the connectors.

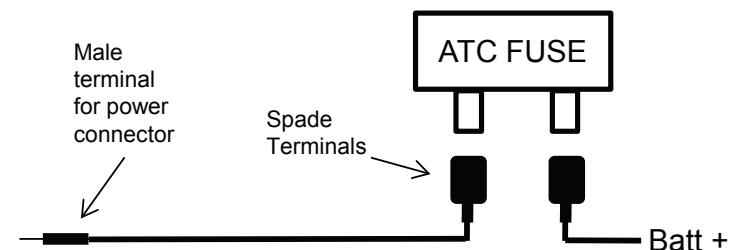

- Using the fuse-protected test lead, connect one wire to the positive terminal of a battery (any battery is OK as long as it matches the voltage of the aircraft battery). Check that the negative on the battery is attached to the ground terminal or airframe.
- For each 2A, 3A, 5A, 10A and 15A circuit, push the male terminal from the test wire into the connector (the female connector with the wires going to it) and verify the device turns on. Note that certain devices may have multiple independent power inputs, like a Garmin 430 or SL-30.

Connect the test lead to the female connector with the wires going to it, not the male pins on the VP-X.

- Insert the wire into J10 Pin 1 and turn the starter switch and verify starter contactor operation by an audible click. **Be sure starter contactor is not connected to the starter** (until testing is completed).
- Connect the other test lead wire to ground. Insert the wires into J12 Pin 5 and Pin 6 and verify the flap motor operates through its expected range of motion. Flipping the pins will change the direction of the motor.
- Verify correct operation of the master switch. The PPS is silent when turned on, but a traditional contactor will have loud click closed when the switch is on. Turn off the master switch.
- Using an ohm meter or test lamp, verify each of the two ground wires is grounded properly.
- Using the 22 gauge wire with the female d-sub terminals, connect one wire to the positive terminal of a battery (any battery is OK as long as it matches the voltage of the aircraft battery). Check that the negative on the battery is attached to the ground terminal or airframe.
- Connect the other wire to ground. Insert the wires into the correct trim motor power terminals and verify the trim motor operates through its expected range of motion. Flipping the pins will change the direction of the motor.
- Verify each of the devices connected to the 2A circuits powers on when the test lead is connected to J1.

- Using an ohm meter or test lamp, verify each of the pins coming from a panel switch is grounded when the switch is turned on.
- Turn off the master switch.
- Remove any test leads and do a sweep to check for loose or exposed wires. Leave the large wire to the starter disconnected until asked to re-connect in the ground testing phase.

You are now ready to power up the system.

- Install each connector on the VP-X.
- Turn on the master switch to turn the system on. On a new VP-X, the EFIS power is set to “always on” until you assign it to a switch, however, we do recommend leaving it in the always on assignment so that electrical information is available as soon as the screen boots up. The switches and other functions will not work until the system is configured.

Note	If you notice anything unusual, turn off the master switch immediately.
-------------	---

6. Configure the System Settings

You are now ready to configure the VP-X to operate in your particular aircraft. This section describes each part of the setup process.

Configuration and firmware updates for the VP-X Pro and Sport are performed using the VP-X Configurator application, which is available for download from the VP web site and installation on a Windows PC. Firmware upgrades to the VP-X must be done using the VP-X configurator. The EFIS itself must be configured to recognize and work with the VP-X Pro and Sport.



Note that you can configure the VP-X as a standalone unit – you do not necessarily need the EFIS to be connected. This allows you to configure and test the system during the build process. The VP-X Configurator application allows you to configure settings, turn devices on and off, reset faults, and update firmware. The application is free on the VP web site.

The VP-X comes from the factory with no switches operable, the trim and flaps are disabled, and the circuit breaker values set to 2 amps. Therefore, the system needs to be configured before it can be operated.

Use the output from the VP-X online Planner as your guide during setup.



When your battery voltage drops, some avionics may not turn on or will exhibit erratic behavior. Monitor your battery voltage while configuring your VP-X and other avionics! Trickle chargers cannot hold the battery voltage up while the avionics are turned on. Most avionics are designed to work about 10 volts, and the VP-X is designed to work above 5 volts.

6.1 Configuring the AFS EFIS

The AFS EFISs includes full setup menus for the VP-X (original version) but these should not be used with the VP-X Pro or Sport.

Turn on the master switch and verify the VP-X is turned on by looking for the blinking orange lights on the Ethernet jacks.

Follow these steps within the EFIS setup pages:

1. Under 1. Admin Settings -> Serial Port Functions, set the serial port that is connected to the VP-X Pro or Sport to “VPX”.

2. Under 36. VP-X Configuration, set the type to either VP-X Pro or VP-X Sport.
 - a. If the VP-X is not connected, it will show just VP-X. You must connect and power the VP-X so that the setup menu shows VP-X Pro or Sport.
3. All further setup should be done using the VP-X Configurator application.

6.2 Configuring the GRT EFIS

The GRT EFISs include full setup menus for the VP-X (original version) but these should not be used with the VP-X Pro or Sport.

Turn on the master switch and verify the VP-X is turned on by looking for the blinking orange lights on the Ethernet jacks.

Follow these steps within the EFIS setup pages:

1. Under General Setup, set the serial port that is connected to the VP-X Pro or Sport to “Vertical Power VP-X PRO” or “Vertical Power VP-X Sport”. Configure both the transmit and receive (in and out) ports the same.
2. Set the serial port rate to 57600. Press Main soft key.
3. Under Display Unit Maintenance, select VP-X Configuration item.
 - a. Verify the software version is the latest.
 - b. Set the aux battery to yes if you want to display the aux battery voltage on the EFIS.
 - c. Press Save.
4. All further setup should be done using the VP-X Configurator application.

6.3 Configuring the MGL EFIS

Turn on the master switch and verify the VP-X is turned on by looking for the blinking orange lights on the Ethernet jacks.

Follow these steps on the EFIS:

1. Press the blue Menu/Setup button twice. Press the page down arrow. Press 1 to enter the System Setup Menu. Press the down arrow twice, then press 8 to enter Serial Port Routing/Allocation. Set the serial port to VP-X Pro or Sport.

6.4 Configuring the Garmin G3X EFIS

Turn on the master switch and verify the VP-X is turned on by looking for the blinking orange lights on the Ethernet jacks.

Follow these steps within the EFIS setup pages:

1. Under COMM page in the setup, set the MFD serial port that is connected to the VP-X Pro or Sport to “Vertical Power”.
 - a. A green check mark in the left column indicates it is receiving data from the VP-X.
2. The trim and flaps are automatically configured to read their position from the VP-X. If you have a third trim axis wired into the G3X analog position input, you can configure it in the trim and flap setup as described in the Garmin manual.
3. You can configure the Amps gauge to display amps from the VP-X instead of from an external shunt.

6.5 Configuring the Dynon SkyView

Turn on the master switch and verify the VP-X is turned on by looking for the blinking orange lights on the Ethernet jacks.

Follow these steps within the EFIS setup pages:

1. Verify you have SkyView version 3.2 or higher installed. If not, go to the Dynon web site and download and install the latest software.
2. Verify you have entered the license key to enable the VP-X functionality on the SkyView (Local Display Setup -> License). Please contact Dynon or your dealer if you do not have a license key. Vertical Power Support cannot issue a license key.
3. Go to System Setup
4. Go to Serial Port Setup
5. Go to the serial port which is wired to the VP-X
6. Choose VP-X as the serial in device.
7. Verify the TX and RX Counters are incrementing. If not, verify the VP-X is on and double-check your data wiring.
8. Go to VP-X Setup in the SkyView Setup screen. Configure the ranges to match your settings. Set the trim and flap settings to “VP-X”.

9. To display a starter annunciator or VP-X master warning, go into the EMS screen layout, select the appropriate size screen, choose info, and choose the VP-X fault or starter widget.
10. The diagram above the list of devices on the SkyView screen can show VP-X current as well as alternator b-lead current and battery current if you have shunts installed. You can display or hide these values. To hide them, select “other” for the shunt location in the VP-X setup. To show them, select the appropriate input source.
11. You can also configure settings for the battery and alternator current shunts (if installed) from the VP-X setup page.
12. To configure the trim and flap indicators to use the VP-X as the position source, go to hardware calibration -> EMS calibration -> and then flaps or trim. Next go to hardware config and calibrate the inputs. NOTE: You must calibrate the trim and flap positions on the VP-X FIRST, then calibrate them on the SkyView. DO NOT put a zero (0) in the trim position endpoint field – use 1 instead.

From the main screen you can access the VP-X page by pressing ENGINE then pressing VP-X.

6.6 Installing and using the VP-X Configurator

The VP-X Configurator is a Windows-based application that can be downloaded from the Vertical Power web site under Support -> Software Upgrades -> VP-X Pro and VP-X Sport.

- [Read the release notes](#) on the download page for instructions on using the VP-X Configurator.
- Follow the instructions below to configure each of the individual items.

6.7 Switch Input Verification

In the VP-X Configurator, go to System Status and verify the status (on/off) of each of the switches.

- Turn each switch on and verify the display shows that switch is on.
- Turn each switch off and verify the display shows that switch is off.

6.8 Device Configuration (Starter, Avionics, Lights, etc.)

In the VP-X Configurator, go to Device Configuration. Each device (lights, transponder, radio, EFIS, etc.) that is powered by the VP-X must be enabled and configured to operate correctly. Configure each device as specified in the Load Planning Worksheet.

For each device:

- Enable the circuit and type in the device name
- Configure each of the electrical devices.
- Press **Update** when done with each item.

6.9 Current Fault Detection

Current fault detection is a feature that detects an absence current when a specific device is turned on. If a device is turned on and draws less than 100 milliamps (1/10 of an amp) for 3 seconds, it will trip the circuit and display a “Current Fault.” Used properly, this feature can indicate failures before they are otherwise noticeable. Used incorrectly, it will lead to nuisance trips.

While each builder’s situation is different, we recommend the following:

Enable current fault for:	Do NOT enable current fault for:
Landing lights	Alternator field
Taxi lights	Avionics that you can see on the panel
Nav lights	Avionics with very low current draw
Strobe lights	LED lights with very low current draw
Boost pump	Devices that are not switched by the VP-X
Avionics fan	(that have their own power knob, or a switch is installed in series between the VP-X and the device).



Wait until all your devices are installed, tested and working properly before turning current fault detection on.

6.10 System Configuration (Over-voltage and Backup Alternator)

The primary alternator is configured using a unique setup screen.

- Configure the over-voltage trip level. Set to 16v for 14v systems and 32v for 28v systems.

The backup alternator configuration must follow these rules.

- J12-10 (3A-1), starter (J10-1), EFIS (J12-9), or primary alternator (J12-11) cannot be used for the secondary alternator.
- Alternator pin(s) cannot be set with current fault detection enabled.
- The secondary alternator cannot be assigned to a pin that is already configured for wig-wag.
- The secondary alternator cannot be assigned to a pin whose switch is the same as the primary alternator.
- A pin already assigned as the secondary alternator cannot be assigned to the same switch as the primary alternator.
- The primary alternator pin cannot be assigned to the same switch as the secondary alternator.
- The switch assigned to the secondary alternator device cannot be assigned to the primary alternator.

If the backup alternator is installed:

- Set the circuit which is used to power the backup alternator. This must be specified or the overvoltage protection and lockout protection on the backup alternator will not work.
- Press **Update**.

6.11 Wig-Wag Configuration

In the VP-X Configurator, go to Wig Wag Configuration.

XeVision HID light customers: The VP-X includes a license to use the patented XeVision warm up and pulsing algorithms and therefore the VP-X wig wag will not void the XeVision warranty. Set the warm-up period to 30 seconds for XeVision HID lights.

Note	If your lights have a built in wig-wag circuit, use the functionality in the VP-X. The wig-wag in the VP-X has many advanced features and is designed to work as part of the overall system. We do not recommend using an external wig-wag system. Typically, there is a second power pin, a sync wire, and/or a master/slave wire, all of which should not be wired. Wire only the primary power wire and ground wire on each light.
-------------	---

Wig wag on the VP-X is activated automatically when the lights are on and the aircraft is above the specified airspeed. There is not a dedicated wig-wag switch.

A pin used for wig wag cannot be set to always off, always on or as the secondary alternator.

Do the following to configure wig-wag:

- Set the warm-up delay. A 5-second delay minimum is required to detect no-current or over-current conditions. We recommend a minimum 30 second warm up period for HID lights. Check with your manufacturer for specific timing.
- Set the indicated airspeed above which the devices will wig-wag. If the lights are turned on below that speed, they will be steady, then wig wag automatically above that speed. If this is set to 0 the pin or pins will always wig wag when turned on (this is primarily so you can test the wig wag feature during the build process).
- Select one or two power pins to wig wag. If only one power pin is selected, it must be assigned to the pin #1 wig wag slot. Set both pins to Disable to disable the wig-wag feature.
NOTE: The pin must be assigned to a switch prior to enabling it for wig-wag.

6.12 Trim Configuration

In the VP-X Configurator, go to Pitch Trim Configuration. Follow the instructions below and repeat for roll trim.

You can run the trim from both a trim switch as well as from the VP-X Configurator.

The position sensor range is 0 to 255. The limits are set numerically based on actual feedback from your sensor. Below is a diagram showing what some typical limits may be:

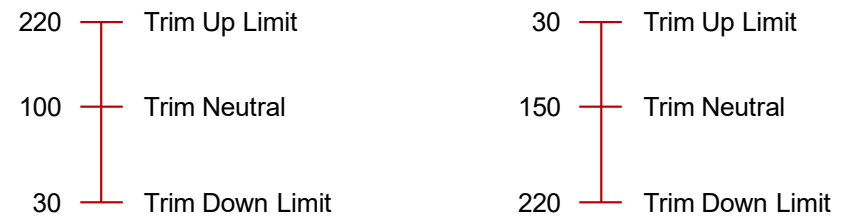

Depending on your installation the up limit, for example, may be a high number or a low number. The actual number is irrelevant – it simply refers to a trim position.

The Ray Allen trim servos automatically stop at the mechanical limits of travel.

Each of the two trim setup pages is similar. Repeat the following for both the pitch and roll trim.

	Verify that each trim switch is in the neutral (middle) position, and that the area around the trim motor/tabs is clear before starting configuration.
--	--

	When operating the trim motor for the first time, carefully check that airframe components don't bind or bend under the motor load.
---	---

The following trim items can be configured:

Motor polarity	Standard/Inverted. Press the Up or Down buttons on the Configurator, and the trim should move in the appropriate direction. If not, change the polarity until the trim runs in the correct direction. Down trim is usually the forward switch, and trim up is usually the aft switch. The elevator trim tab should run down when pressing the up trim button. Once the motor direction is correct, <u>verify that each trim switch is wired correctly</u> by moving the trim using the trim switch on the stick (note: press Update button to save settings before using trim switch)
Up limit	Run the trim all the way up using the Up soft key. Note the number that shows the trim position (should be on the screen, between 0 and 255).
Neutral position	Run the trim to the neutral position using the Up/Down soft keys. Note the number that shows the trim position (should be on the screen, between 0 and 255).
Down limit	Run the trim all the way down using the Down soft key. Note the number that shows the trim position (should be on the screen, between 0 and 255).

Variable Trim Speed (Pitch only)

Reduce Power above	Set the indicated airspeed above which the pitch trim runs at a slower speed. Set to 0 to disable this feature.
% Power	Set the percentage of full speed that the pitch trim motor should run when the aircraft speed is above the 'reduce power above' speed. 70% is a good starting point. Range is 40% to 90%.

- Configure the pitch trim settings so they match your desired final configuration.
- Configure the roll trim settings so they match your desired final configuration.

6.13 Flaps Configuration

In the VP-X Configurator, go to Flaps Configuration. You can run the flaps from both the flap switch as well as from the VP-X Configurator.

The flap switch runs the flaps either in either momentary or position mode (see below). When you run the flaps from the EFIS, the flaps only run while the flap control button is pressed.

	Verify that the flap switch(es) is in the neutral (middle) position, and that the area around the flaps is clear before starting flap configuration.
---	--

	When moving flaps for the first time, carefully check that airframe components don't bind or bend under the motor load.
---	---

The following flap items can be configured:

General Configuration

Flap enable	Enable/Disable. Set to enable if the VP-X controls the flaps. Set to disable if your flaps are not directly controlled by the VP-X.
Flap control	Position/Momentary. Position: flaps can be set to stop at intermediate positions (requires position sensor). Momentary: flaps run only when flap switch is pressed. <u>Set this to Momentary for now</u> . You can set it to position once the initial engine and airframe testing is complete. This is because the position setting may operate differently in the air than on the ground (due to air loads) and fault the flap circuit due to motor run-on. We recommend deferring this uncertainty until later in the flight test period.
Circuit breaker	Set the circuit breaker value for the flap motor circuit.

Motor polarity	Standard/Inverted. Press the Up or Down buttons, and the flaps should move in the appropriate direction. If not, change the polarity until the flaps run in the correct direction. Press Update . Once the motor direction is correct, <u>verify the flap switch is wired correctly</u> by moving the flaps using the flap switch (note: press Update button to save settings before using flap switch)
Slow Retract	When this feature is enabled, the flaps retract at approximately 50% slower speed than normal while the engine RPM is <u>above</u> the configured RPM limit.
Flap Reflex	Midpoint 1 must be set, and flaps must be set to "Position" as described above. Midpoint 1 position should be set to the neutral position, and UP should be set to the reflex position, as described below. See "10.5 Trim and flap operation" on page 68 for more details.
Continuous Flaps	Allows you to command a further flap down position before the flaps reach the next stop. If enabled, you can bump the flap down switch while the flaps are moving down and it will continue to the next down position. Must be used with flaps in "Position."

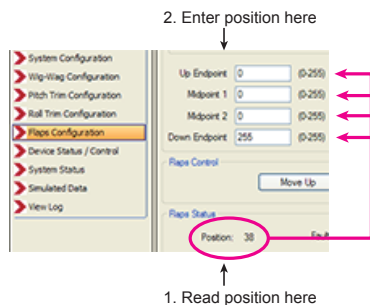

Reading and Entering Flap Position on the VP-X Configurator

Note	The Up/Dn and midpoint limits only need to be set if a position sensor is installed.
-------------	--

Up limit	Run the flaps all the way up using the Up soft key. Note the number that shows the flap position (should be on the screen, between 0 and 255). We recommend setting it a few numbers short of the actual limit to allow for position slop.
Midpoint 1/2	Allows you to set intermediate flap stops. These are disabled when the flap control is set to Momentary. Disregard for now. Note: if these are set to non-zero values, they must be in numerical order consistent with the up and down limits or an error occurs during save.
Down limit	Run the flaps all the way down (or the desired end point) using the Down soft key. Note the number that shows the flap position (shown on the screen, between 0 and 255). We recommend setting it a few numbers short of the actual limit to allow for position slop.



Note on up and down limits:

Make sure the limit value (the number 0 - 255 corresponding to the position) is set before or at the point of the physical limit. For example, if the down limit value is set to 0, but the furthest it goes is down to 8, then it will never reach zero and continue to drive the motor in anticipation of reaching zero. The flap circuit will reach the max run time of 45 seconds and then the circuit will fault.

<p>End Point Extent</p>	<p>Only applies if Flap Control is set to <i>Position</i>. Time in seconds that the flaps will run extra when at the top and bottom travel limits. This is to eliminate the slop inherent in the position sensor, which is used to stop the flaps at the top, bottom and intermediate position. We recommend this is set to about 0.5 seconds.</p> <p>Use the example below to see how using this feature can eliminate slop in the position sensor. For the settings at both the top and bottom stops, you should set the value so some number “inside” the range so that the sensor will cause it to stop early, then the <i>end point extent</i> time will run the flaps to the end. Additionally, air loads during flight will likely change the readings somewhat, and this technique will account for that as well. Note that the actual readings may be reversed in your installation.</p> <table border="1" data-bbox="409 646 907 943"> <thead> <tr> <th></th> <th>Actual Reading</th> <th>Recommended Setting</th> </tr> </thead> <tbody> <tr> <td>Top</td> <td>→ 12</td> <td>→ 20</td> </tr> <tr> <td>15°</td> <td>→ 48</td> <td>→ 48</td> </tr> <tr> <td>Not used</td> <td></td> <td>0</td> </tr> <tr> <td>Bottom</td> <td>→ 248</td> <td>→ 240</td> </tr> </tbody> </table>		Actual Reading	Recommended Setting	Top	→ 12	→ 20	15°	→ 48	→ 48	Not used		0	Bottom	→ 248	→ 240
	Actual Reading	Recommended Setting														
Top	→ 12	→ 20														
15°	→ 48	→ 48														
Not used		0														
Bottom	→ 248	→ 240														
<p>Max Flap Speed</p>	<p>The IAS above which the flap down switch is disabled and the flap over speed alarm is triggered. Set this value to 0 to disable both the flap down switch disable function and the flap over speed alarm.</p>															
<p>Over speed Position</p>	<p>The flap position below which the flap over speed alarm is triggered. If the flaps are BELOW this setting and the IAS is higher than the Max Flap Speed, the Flap Over speed alarm is activated. Since each aircraft is different, this speed may correspond to 10° of flaps, or maybe 30°. We recommend you set it somewhere just a bit BELOW the flap up setting. When we say BELOW we mean the actual physical flap position, not the numerical value used to show the position. Following are some examples:</p>															

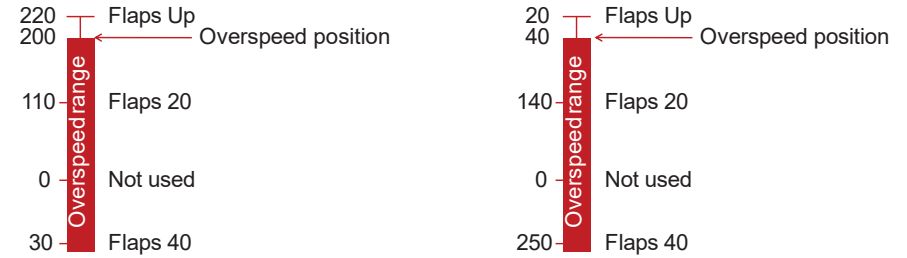

- From the Flap Configuration page, enable the flap circuit and press Update.
- Set the flaps to momentary.
- Set the circuit breaker value.
- Press Update. Run the flaps using the buttons on the Configurator. If the flap motor direction is backwards, change the motor polarity setting. Press Update.
- Run the flaps using the flap switch. If the flaps run backwards, the flap switch inputs are wired backwards.
- Calibrate the top and bottom positions, and optionally the middle stops.

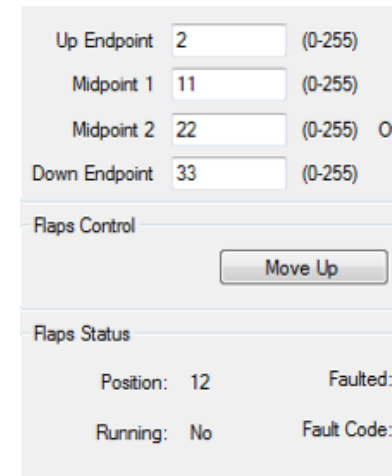

As you run the flaps, the position number changes. The number should change throughout the entire range of flap motion. If it does not, then the position sensor is binding at the ends and you should

adjust the mechanical linkage so there is some slop at each end of travel. If the number does not move at all, double check the position sensor wiring.

- If you want to use the RV-10/RV-14 flap reflex settings or “continuous flaps” setting, enable these settings after a few flights in the aircraft.
- Press Update.
- After the first few flights in the aircraft, go back and update the rest of the settings to your desired configuration.

See “9.1 Flap Configuration” on page 65 for more detailed information.

Note	Because air loads on the flaps cannot be simulated on the ground, you may have to modify the limit settings once you begin flight testing. See the troubleshooting section in this manual if your flaps are not operating properly.
-------------	---

Note	If the flap motor runs more than 45 seconds, the motor is stopped and a fault is generated.
-------------	---

6.14 Export Settings

Save your settings to your PC. Go to the *File* menu, then *Save Configuration As...*

6.15 Import Settings

You can restore your saved settings using the file previously saved. Go to the *File* menu, then *Open Configuration...*

	Do not shut off the system while the import is in progress.
---	---

7. Ground Test

The ground test steps are performed in two parts: the first part without the engine running and the second part with the engine running.

7.1 Testing without engine running

Perform the following steps without the engine running. The battery will drain during testing, so have either a charger or ground power available.

- With the master switch off, turn on the each backup circuit and verify the respective device turns on. Turn off backup circuits.
- Turn on the master switch
- Verify that each of the switches turns on the expected devices. Wait to test the alternator switches until the engine is running.
- Verify the pilot flap switch operates as expected.
- Verify the co-pilot flap switch operates as expected.
- Verify the pilot trim switches operate as expected.
- Verify the co-pilot trim switches operate as expected.
- Test the runaway trim system. If able, introduce opposite inputs from the same stick or from both the pilot & co-pilot sticks (i.e. trim up and down at the same time). Verify a fault after 3 seconds. Clear the fault. Verify backup trim operation on the EFIS screen and reset fault. Verify normal operation.
- Verify aux battery voltage display is correct (if installed)
- Turn off the master switch

7.2 Testing while engine running

This section verifies the proper operation of the VP-X with the engine running. The main objectives for this section are:

- Verify engine starting and proper mag operation
- Verify starter annunciator
- Verify proper alternator operation

If this is coincident with first engine start, be sure to integrate the kit manufacturer's first engine start safety procedures with the test plan specified herein. You may consider first verifying proper operation of the engine and once that is complete, begin the electrical system test.

Prolonged low-power operation of a new engine may adversely affect the engine. Be sure you understand the engine break-in requirements, and balance those against the time needed to test the electrical system.

These procedures are published as a guideline. Follow the engine manufacturer's starting and safety procedures.

- Ensure that the battery is fully charged. If the voltage drops rapidly during engine start, then the battery is bad or not fully charged.
- Start the engine and verify the starter circuit is operating correctly. If the starter annunciator circuit is enabled, verify the starter annunciator comes on during start.
- Note the bus voltage. Then turn on the primary alternator.
- The voltage should increase to 14.2 volts +/- 0.3 volts (check with your alternator manufacturer for specifics)
- Turn off the primary alternator and note the bus voltage drop to about 12.5 volts.
- Run the engine up to about 1600 RPM and turn on the backup alternator. The bus voltage should increase from about 12.3 volts to about 14.0 volts.
- Turn off all the switches.

8. Flight Test

This section verifies the proper operation of the VP-X during flight.

Prior to flight, make sure you understand the following, which is described in the Operating section:

- How to clear faults
- How to switch devices on and off manually
- How the runaway trim system operates

This section provides a series of recommended steps, and you should incorporate these steps into the overall flight test plan as you deem appropriate. Go back and review the ground test steps, as complete and thorough ground testing will mitigate the risk of trouble while airborne.



Do not fly the aircraft until you are comfortable everything operates correctly on the ground, and you are knowledgeable about the systems and their proper operation.

8.1 Notes about first flight

It is the pilot's responsibility to develop a test plan that ensures a safe and productive first flight. Typically, the first flight is focused on verifying basic flight characteristics and proper engine operation. With that in mind, we recommend deferring complete electrical system tests until after you are comfortable that the engine and airframe are performing as expected, and you are comfortable flying the aircraft. We recommend the following configuration for first or early flights, and it can easily be changed for later flights:

- Configure the flaps to operate in *momentary* (flaps only move when the flap switch is pressed). It may take a few flights to “dial in” the proper limit settings for *position* (flaps move to next position when flap switch pressed), and you can do that once the basic flight characteristics are proven.
- Be sure to review how to acknowledge and/or reset circuit faults.

If you are installing the system as a retrofit, it is still important to complete as much of the testing on the ground as possible.

8.2 VP-X system checkout

Now that initial aircraft checkout flights are complete, you can proceed with the electrical system tests.

Once airborne, keep an eye out for traffic and obstacles during the test procedure. Carry a handheld radio as a backup in case of electrical system failure. If you encounter any difficulties in flight due to improper setup or unknown electrical system behavior, land as soon as practical or simply turn off the master switch. If you have completed a thorough check out on the ground, the chances of problems while airborne are greatly reduced.

Verify each of the following in flight:

- Verify devices turn on and off when switches are turned on. Looking at the individual current draw is an easy way to verify something is turned on.
- Verify variable speed trim works as configured.
- Verify wig-wag operates as expected. Note: it may be easier to test wig-wag on the ground using simulated data from the VP-X configurator.
- Verify flaps operate as expected. The air loads may necessitate minor changes to the flap settings if configured with intermediate flap stops.

9. Troubleshooting

Follow these instructions for each system.

Please contact Vertical Power Support at 425.328.1658 if you have any questions.

9.1 Flap Configuration

Verify correct flap operation by following these steps, IN ORDER:

1. Connect the VP-X Configurator and select the flaps section.
2. Enable the flaps and press 'Update' button.
3. Set the flaps to 'Momentary' and press 'Update' button.
4. Verify that the 'Faulted' field (under flap status) is No.
5. Move the flaps using the up and down buttons on the Configurator. If the flaps move in the opposite direction, then change the motor polarity setting and press 'Update' button.
6. Move the flaps using the flap switch installed in your aircraft. If the flaps move backwards, then the flap switch inputs are reversed.
7. If a POS-12 is installed, verify the number next to the 'Position:' label (under flap status section) changes as you move the flaps. This number could range between about 0 and 255 as move the flaps through their FULL travel range.
8. If the position value does not change, then the position sensor wiring is incorrect.
9. The number SHOULD ACTUALLY span a smaller range of 20 to 240 or so. If it goes all the way to either 0 or 255 then the sensor has hit its limit and you won't get an accurate reading at the endpoints, which is important. Change the mechanical linkage so that the sensor does not hit its limits.
10. Run the flaps up and record the top position reading on paper. This is a number between 0 and 255.
11. Run the flaps to each intermediate stop (if any) and record the position reading(s) on paper.
12. Run the flaps to the bottom position and record the bottom position reading on paper.
13. If you have the flap system in 'Momentary' the position values are used only to display the flap position on the EFIS. However, if you want to use the 'Position' mode, then the position values are used to stop the flap motor at the top, middle, and bottom positions.
14. In some instances the top position may be near the 0 value, or it may be near the 255 value. It just depends on how the mechanical linkage is designed. Either way is fine. The bottom position should be on the opposite end of the 0-255 range from the top position.
15. The position sensor combined with the mechanical linkage has some slop in it. To account for this slop, the VP-X can run the flap motor slightly longer than needed so that the flaps are fully retracted. To accomplish this, set the 'End Duration' to 0.5. This will run the flaps for an extra half second at both the top and bottom limits, when in position mode.
16. Set the top, bottom, and midpoint values in the configurator. We will use an example here, but your values may be on the opposite end of the scale. If the top value you recorded above is 10, then set the value to 20. The end duration should run it up to 10, as it will run for one half second past when it reaches 20. You can then adjust the numbers as necessary.
17. Enter the mid-point values exactly as you recorded them above.
18. The bottom value is the trickiest to set correctly because the loading on the flaps is different in the air than on the ground, so the down value may be different in each case.
19. If the recorded down value is, for example, 240 on the ground, it might be 235 in the air because the air loads on the flaps do not allow the flaps to fully extend as they do on the ground. To solve this using this example, set the down value to 230. The system will then run the flaps for half a second after it reaches 230. If the down value were to be set at 240, the position sensor may never report 240 and only get to 235 which causes the flap motor run-on protection to trip the flaps after running for 45 seconds.
20. For the first few flights we recommend running the flap system in 'Momentary' mode. After you are comfortable with the airplane, then set it to 'Position' if so desired.
21. Set the flap system to 'Position' and press 'Update' button.

Problem	Solution
Flaps go up, but not quite all the way	<ul style="list-style-type: none"> Run the flaps using Momentary and verify they operate correctly through the whole range. If limit switches are installed, adjust them or the linkage so the flaps operate correctly. If flaps are set to stop at intermediate positions, be aware there is some slop in the position sensor, so you need to compensate for that which can be easily done. The <i>end point extent</i> feature runs the flaps for an extra period of time (configurable) at the up and down limits to make sure they hit their full limits. Use the <i>end point extent</i> setting (under Flap Setup) to run the flaps a little extra, and set the stop limits a bit shy of the ends. For example, if when your flaps are all the way up, it shows the position indicator at 4 (under flap setup). Then set the top limit at 10 and set the end point extent value to 1.0 seconds. This is only an example, but shows that you put some slop in the stop value (10) and then added an extra second of flap motor run time to make sure they go all the way up mechanically.
Flaps run on and trigger the <i>Max Run Time</i> which causes a fault.	<ul style="list-style-type: none"> If the flaps are all the way up or down, and slop in the position sensor causes the system to think the flaps have not reached their limits, it will continue to run the motor until it triggers the max run time fault (45 seconds). This is designed to keep the motor from running indefinitely and burning out in such situations. See above for solution.
Flaps worked fine on the ground but faulted in the air.	<p>Since the air load on the flaps cannot be simulated on the ground you may have faults in the air until you “dial it in”. Check:</p> <ul style="list-style-type: none"> Circuit breaker value for the flap circuit. The current draw is higher in the air than on the ground. Sensor slop which may cause faults mentioned above.

Flaps **work in momentary but do not work when set to position** (intermediate flap stops).

Please follow these steps carefully in the order shown:

- Connect the PC application to the VP-X via the Ethernet cable.
- In the setup menus, set the flap system to ‘momentary.’ Set End Travel to 0.5. Press Save. Move the flaps to the middle of their travel. Turn off the master switch.
- Remove J2 (25 pin d-sub connector) from the VP-X. Verify the flap switch input pins are correct on the male J2 connector (the one connected to the wires). Verify J2 pin 15 is grounded when the flap switch is pressed down. Verify J2 pin 14 is grounded when the flap switch is pressed up. It is easy to wire this backwards. Swap the wires if they are incorrect. Reinstall J2 and turn power on.
- Press the flap down switch and the flaps should run down. If not, change the motor polarity in the setup menus so that the flaps run in the correct direction.
- Now the switch inputs and the motor direction are correctly wired and configured. The next step is to verify the position feedback is correctly calibrated.
- On the EFIS display verify the flap indicator corresponds to the actual position of the flaps. If the display shows down when the flaps are up and vice versa, the top and bottom limit settings must be changed in the setup menus. Internally, the flap position is reported using a number range from 0 to 255. Sometimes a low number means the flaps are up and sometimes a high number means the flaps are up. Each installation is different. You must set the limits to match your installation. Please see the flap configuration section earlier in this manual for the correct steps.
- Once the new values are entered and saved, verify the flap position indicator reads as expected. The position indicator on the display should just reach UP when the flaps are all the way up, and should just reach DOWN when the flaps are all the way down. Leave the flaps in the middle of their travel range.
- Go back into the PC application and change the flap configuration to ‘position.’ Set the intermediate stops if desired. Set one or both to 0 if that position is not needed. Press Save and exit the setup menu.
- Verify the intermediate stops work correctly.

9.2 Electrical Configuration

Problem	Solution
Nuisance trips	<ul style="list-style-type: none"> Verify with the manufacturer of the electrical device that you've used the correct circuit breaker value. Do not increase the CB value over what the wire can support. Use these for guidelines: 14 gauge wire – 15A max 18 gauge wire – 10A max 20 gauge wire – 5 A max If nuisance trips persist, contact Vertical Power Support.

9.3 Trim faults

Problem	Solution
Trim faults at power on	<p>The trim is designed to fault if any of the trim switches are on at power on.</p> <ul style="list-style-type: none"> Verify that none of the trim switch input wires are shorted to ground. Verify that none of the trim input switches are closed.
Cannot clear a trim fault	<ul style="list-style-type: none"> A trim switch input line is still grounded. You must un-ground the input and re-cycle power to the system.

9.4 “Cannot Connect” error when using VP-X Configurator

Please see the Configurator Release Notes document for troubleshooting instructions. The release notes are available on the Vertical Power website at www.verticalpower.com under *Help* and then *Software*.

10. VP-X System Operation

This section describes the operation of the VP-X. Additional details can be found in the EFIS manual provided by the EFIS manufacturer.

10.1 Power On and Off

Turn ON the VP-X by turning on the aircraft master switch.

When turned on, the VP-X performs the following checks:

Internal data integrity checks. If it fails the internal data integrity checks, the system resets to its default values and the EFIS turns on to display the specific fault. The switch settings, trim and flaps settings are cleared and do not operate. The EFIS may be able to restore the settings to the VP-X. If this failure occurs please contact VP tech support.

Trim and flap input checks. If any of the trim or flap switch inputs are active (i.e. a trim switch pressed) during startup, the trim circuit shows a fault. You must clear the physical fault (either a stuck switch or shorted wire), then cycle power to the system to clear the fault in the system.

General fault checking. If any faults exist on the VP-X at power on, it will automatically turn on the EFIS circuit so that the EFIS can display the fault.

Turn OFF the VP-X by turning off the master switch. Note that backup circuits, if installed, must be turned off as well.

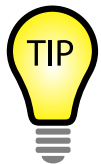

After turning off the VP-X, wait at least 5 seconds before turning the system back on again.

The short delay will give the electronics time to discharge and clear properly.

10.2 EFIS Electrical System Page

When the VP-X is configured to work with a supported EFIS, the EFIS display includes an electrical system page. Each EFIS is different, but in general the EFIS can:

- Show a list of each of the power circuits, including trim and flap
- Show the status of each circuit, whether on or off or faulted (and type of fault).
- Total current draw of all circuits

- View the current draw, in amps, of each circuit. The minimum detectable amount is 100 mA (1/10 of an amp).
- Allow user to reset a faulted circuit.
- Show graphical electrical system diagram, including main bus voltage and aux battery voltage.
- Show VP-X internal temperature
- Allow manual control of each individual circuit, including trim and flaps.

10.3 Other VP-X functions

In addition to the Electrical System page, the following data is used by the EFIS and displayed to the user:

- Trim and flap position
- Trim and flap in-motion indicator
- Pitch trim speed, as a percentage of maximum speed
- Wig wag active indicator
- VP-X system faults (see table at end of this document)

10.4 Turning electrical devices on and off

Devices can be turned on or off in one of several ways:

1. Using the switches wired to the switch inputs on the VP-X.
2. Using the backup switches, if installed.
3. Using the soft keys on the EFIS. This allows you to turn on and off an individual device separately and independently from the switch it is assigned to. Cycling the switch will reset the device back to switch operation.

Only one alternator can be on at a time. If both are turned on, then the most recent one to turn on stays on and the other one is turned off.

10.5 Trim and flap operation

The flaps can be operated by the flap switch or by the soft keys on the EFIS.

The flaps are configured to move in one of two ways:

1. Only when the flap switch is pressed, or
2. Move to the next down position (and all the way up) with a momentary press of the flap switch.

When you press the flap up switch, the flaps go all the way up unless you press the flap down switch to stop them mid-stream. On some aircraft, you can set the reflex position to the top position, the 0 deg position to the first stop, approach flaps to the second stop, and landing flaps to the bottom stop.

The trim operates whenever a trim switch is pressed. The trim runs within the limits specified in the trim setup menus. The trim can also be controlled by soft keys on the EFIS. The pitch trim operates at a two different speeds, which is controlled by airspeed (as reported by the EFIS).

The EFIS displays the trim and flap position.

The maximum time the flap motor can run per switch input is 45 seconds. This prevents the motor from continuously running if the position sensor should fail or a control wire shorts. If the max run time is exceeded, the flap circuit is faulted.

10.5a Trim switch fault detection on startup

If any of the trim switch inputs are active (i.e. a trim switch pressed or switch wire is shorted to ground) during system startup, the trim circuit shows a fault. You must clear the physical fault (either a stuck switch or shorted wire), then cycle power to the system to clear the fault in the system.

10.5b Runaway trim and flaps

Runaway trim or flaps is indicated by both switch inputs being active at the same time. This can be caused by a stuck switch, a shorted wire, or various other causes.

If you discover the trim or flaps running un-commanded, **push and hold** the opposite button to immediately stop the motor. The input switch pairs are as follows:

Pitch Trim	Up	Down
Roll Trim	Left	Right
Flaps	Up	Down

After 3 seconds, the affected circuit faults and you can release the button. A faulted circuit does the following:

- The input switches for the faulted axis are disabled
- An alarm message is shown on the screen
- The EFIS may display soft keys that allow you to run the trim from the display.

For example, if the pitch trim begins to “run away,” hold down the opposite pitch trim switch (a natural reaction, by the way) until the fault shows on the screen. When it does, the switches are disabled.

After a runaway condition, you can re-enable the trim or flap circuit by selecting it from the list of items on the EFIS electrical page and press the “Re-Enable” soft key. You cannot re-enable the trim or flaps if a switch input is active.

10.5c Trim and flap operation with a faulty position sensor

The position feedback is ignored when the trim and flaps are operated using the soft keys on the EFIS. When you select the Flaps from the electrical system page, the EFIS displays the Flap Up and Flap Down soft keys. The display is similar when the Trim is selected. This allows you to run the trim and flaps if a position sensor is showing faulty readings.

10.5d Max Flap Speed Functions

The VP-X can alarm or limit flap functions based on indicated airspeed provided by the EFIS. The following functions are supported, and configurable in the setup menus:

- **Flap over-speed alarm.** When the flaps are extended beyond the specified limit and the indicated airspeed is above the specified max flap speed, then the an alarm is displayed on the EFIS.
- **Disable flaps above max flap speed.** The flap down switch is disabled above the specified max flap speed. You can raise the flaps but not lower the flaps.

The flap disable function is ignored when the flaps are operated from the EFIS.

10.5e RV-10/RV-14 Flap Reflex Operation

When enabled, features specific to the RV-10 & RV-14 are provided:

1. The flaps may be moved from the reflex position to the neutral position at any airspeed. Flap down airspeed limits are ignored above neutral position, and are enforced for positions lower than the neutral position.
2. When pressing the flap up switch, the flaps go up and stop at the neutral position instead of the reflex position. You can then press the flap up switch again to go to the reflex position.

10.5f Continuous Flaps

When enabled, you can command flaps past the next flap down stop before the flaps stop.

For example, if you have flaps 0, 20, and 40 degrees and the flaps are up, you can press the flap down switch twice (push - push) and the flaps will go all the way to 40 degrees. The first time you press the flap down switch, the flaps are commanded to go to 20 degrees. The next time you press it the flaps are commanded to go to 40 degrees.

If this is not enabled, you must wait until the flaps reach the next stop before pressing the flap down switch to go to the next one.

10.6 Landing Light Wig-Wag

If enabled, the forward lights (landing and/or taxi) can be configured to wig-wag (pulse) when turned on. The wig-wag system incorporates the following features:

- Pulsing starts automatically above a specified airspeed, so the lights are steady on the ground but pulsing in the air for increased visibility.
- Warm-up before pulsing. The lights will remain on steady for the specified period of time before pulsing begins. There is a minimum five-second warm-up period to allow the system to detect any circuit faults.
- Pulsing can be manually stopped by pressing WIG-WAG STEADY soft key on the EFIS. Press WIG-WAG AUTO to set back to automatic control. Consult the EFIS manual for specific instructions.

The landing and or taxi lights must be turned on to wig wag. The lights only wig wag if the device(s) is turned.

10.7 Circuit Faults

A circuit fault can be caused by the following conditions:

1. Short circuit: the wire is grounded, either momentarily or permanently
2. Over-current: the electrical load exceeds the circuit breaker value
3. Current fault: the device is drawing no current for three seconds when turned on. This is user-configurable on all circuits except trim, flaps, and starter.

When a fault occurs, the VP-X turns off the circuit. It remains OFF until the fault is manually reset using the EFIS screen. Consult the EFIS manual for specific instructions related to clearing the fault.

10.8 Starter Disable

The starter circuit is normally on, meaning the starter switch has power at all times when the engine is not running.

The starter circuit is automatically turned OFF whenever the engine RPM is valid and is above 600 RPM. You cannot manually turn the starter circuit on and off.

10.9 Low-Voltage Alarm

A low voltage condition is detected and reported by the EFIS.

10.10 Over-Voltage Alarm

The VP-X detects an over-voltage condition, which generally occurs because either the voltage regulator or alternator has failed in a manner that allows the alternator to produce higher voltage levels than normal.

When an over-voltage condition is detected, the active alternator (either the primary or backup) is turned OFF and an alarm is displayed on the EFIS screen.

You can reset the faulted alternator circuit in the same way you reset any other faulted circuit. The alternator switch cannot turn the alternator back on until the fault is cleared.

Because the alternator circuit is disconnected, you will shortly get a low-voltage alarm. When this happens you can switch to the backup alternator.

10.11 Battery Contactor Failure

If the battery contactor fails, power is lost to the main bus and therefore the VP-X. Turn on the backup circuits to provide power to devices wired with backup circuits.

10.12 Backup Circuits

The VP-X allows an unlimited number of backup circuits. Each backup circuit is wired directly to the battery bus through a separate and independent fuse and switch. If a backup switch is turned off, the VP-X controls power to the device. Turning on a backup switch powers the device independently of the VP-X.

The backup switches provide power to their respective devices even after the VP-X shuts off. Remember to turn off backup power after it is no longer needed or when shutting down the aircraft.

10.13 Data Comm Loss

If the data bus between the VP-X and the EFIS fails, the VP-X will continue to operate normally and provide circuit protection. However, any data normally displayed by the EFIS is no longer available. This includes fault display, circuit status, configuration, software updates, and the ability to reset faults.

Additionally, because the EFIS is no longer providing data to the VP-X, the following functions are disabled:

- landing light wig-wag will reset to steady operation
- variable speed pitch trim will reset to normal speed operation
- flap over-speed functions are disabled

10.14 Firmware Updates

Firmware updates are performed using the PC-based Configurator Application. Do not use the firmware update feature on the EFIS for the VP-X Pro and Sport. This is only used for the original VP-X. Firmware updates are available on the VP web site under support, then go to software upgrades. The VP-X settings are kept intact during the firmware upgrade.



Do not cycle power to the VP-X during a software upgrade.

Appendix A – Pinout Diagram

System Name	Bank	Amps Range	Physical Pin	I/O
Flap	B	1-10	J12-5 & 6	O
Starter	A or B	1-10	J10-1	O
EFIS	A	1-5	J12-9	O
Field_Pri	A	1-5	J12-11	O
5A-1	A	1-5	J8-1	O
5A-2	A	1-5	J8-3	O
5A-3	A	1-5	J8-4	O
5A-4	A	1-5	J8-5	O
5A-5	B	1-5	J8-6	O
5A-6	B	1-5	J8-7	O
5A-7	B	1-5	J8-8	O
5A-8	B	1-5	J10-2	O
5A-9	B	1-5	J10-4	O
5A-10	B	1-5	J10-7	O
5A-11	B	1-5	J10-8	O
5A-12	B	1-5	J10-10	O
5A-13	A	1-5	J12-8	O
10A-1	A	1-10	J8-2	O
10A-2	B	1-10	J10-3	O
10A-3	B	1-10	J10-5	O
10A-4	A	1-10	J12-1	O
10A-5	A	1-10	J12-3	O
10A-6	A	1-10	J12-7	O
15A-1	B	1-15	J10-6	O
15A-2	A	1-15	J12-2	O
15A-3	A	1-15	J12-12	O
3A-1	A	1-3	J12-10	O
2A-1	A	1-2	J1-1	O
2A-2	A	1-2	J1-2	O
Trim Roll	A	1	J1-6/7	O
Trim Pitch	A and B	1	J1-11/12	O
S1	A or B		J2-1	I
S2	A or B		J2-2	I
S3	A or B		J2-3	I
S4	A or B		J2-4	I
S5	A or B		J2-5	I
S6	A or B		J2-6	I
S7	A or B		J2-7	I
S8	A or B		J2-8	I
S9	A or B		J2-9	I
S10	A or B		J2-10	I

Other I/O

Function	Pin	I/O
Aux batt voltage	J2-12	I
Starter annunciator input	J2-11	I
Roll trim position	J1-5	I
Pitch trim position	J1-10	I
Serial TX	J1-20	O
Serial RX	J1-22	I
Flap Up	J2-14	I
Flap Dn	J2-15	I
Roll Trim L	J2-16	I
Roll Trim R	J2-17	I
Pitch Trim U	J2-18	I
Pitch Trim D	J2-19	I

Appendix A1 – J8, J10, J12 Connector Wiring

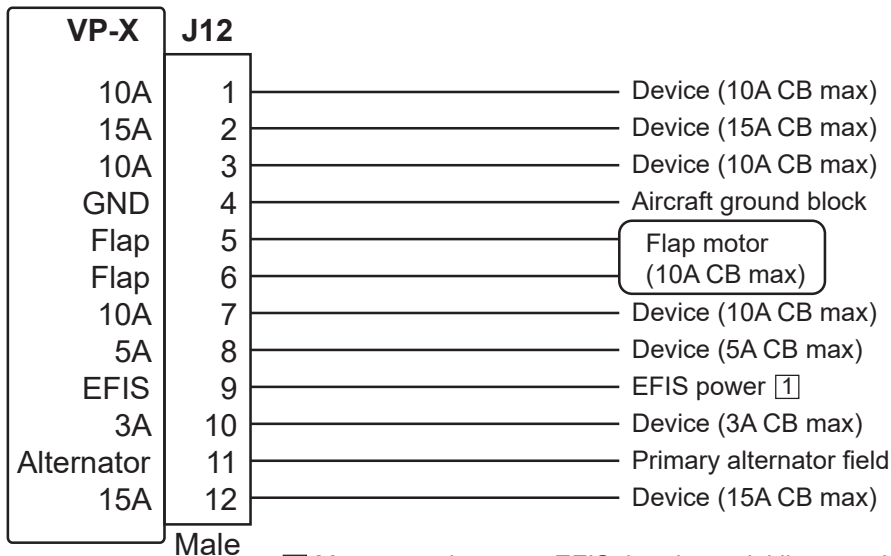
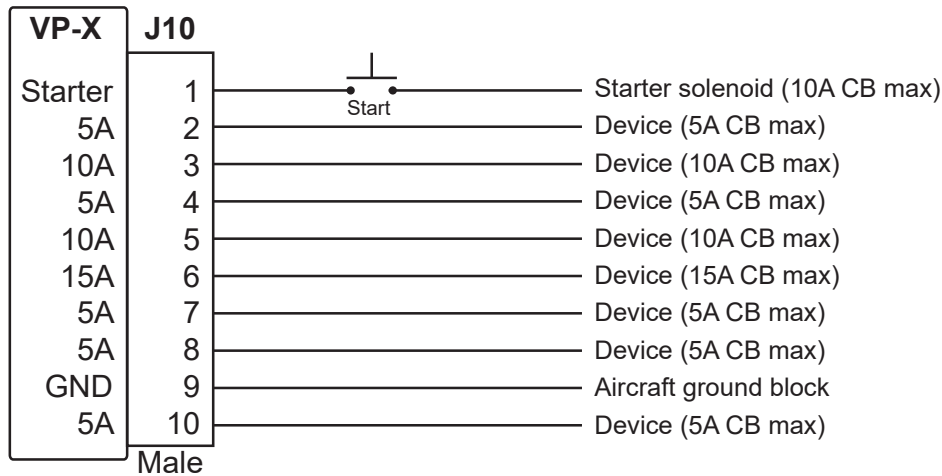
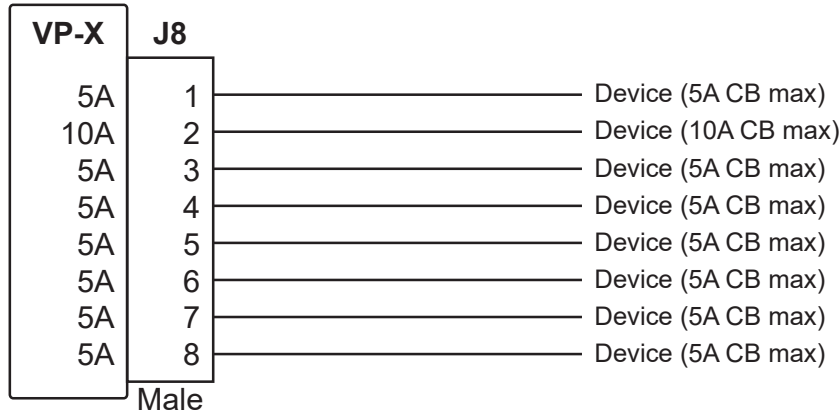

REV A

¹ Must go to the same EFIS that the serial lines on J1 go to.

Appendix A2 – J1 Connector Wiring

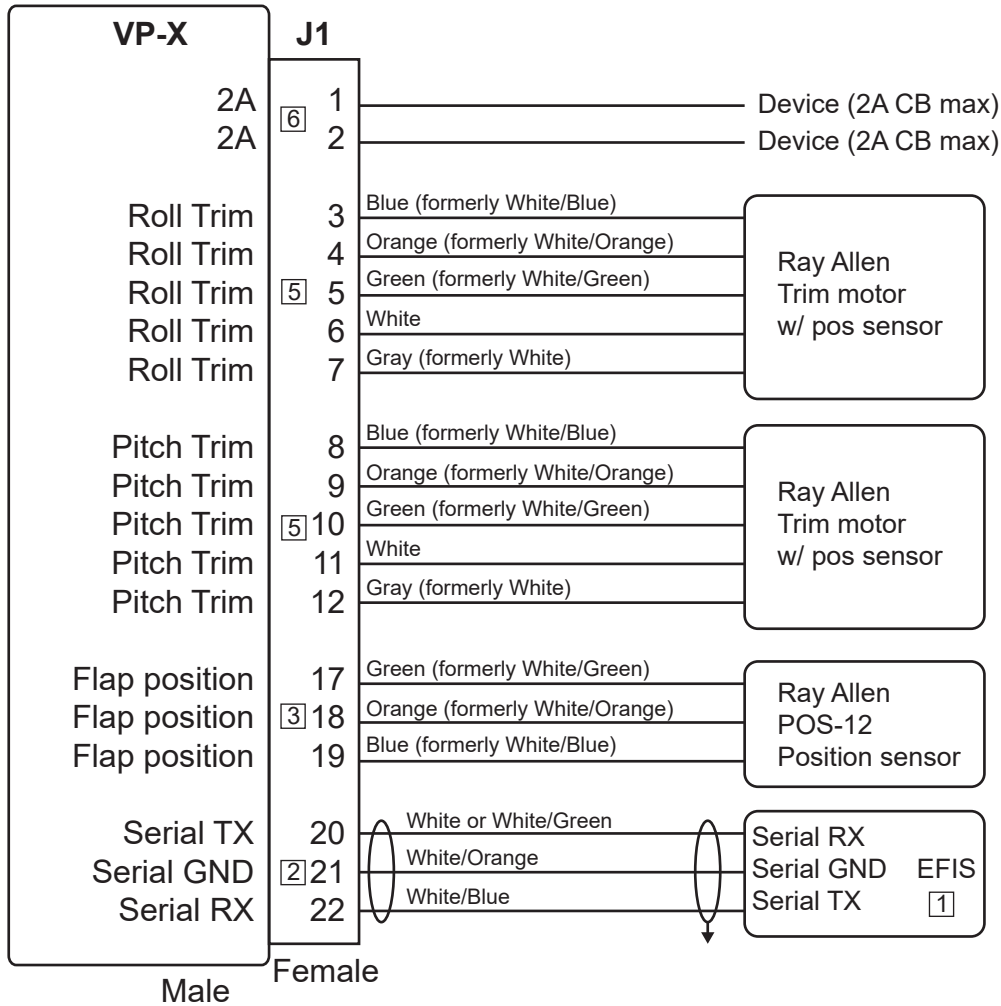

REV A

- ① Serial must be wired to same EFIS that is powered by J12-9. See instructions in manual for Dynon wiring.
- ② Use wire M27500-24TG3T14 (3 conductor, 24 AWG, shielded)
- ③ Use wire 3 conductor, 24 AWG, unshielded or shielded
- ⑤ Use wire 5 conductor, 24 AWG, unshielded
- ⑥ Use wire M22759/16-22 (22 AWG Tefzel)

Appendix A3 – J2 Connector Wiring

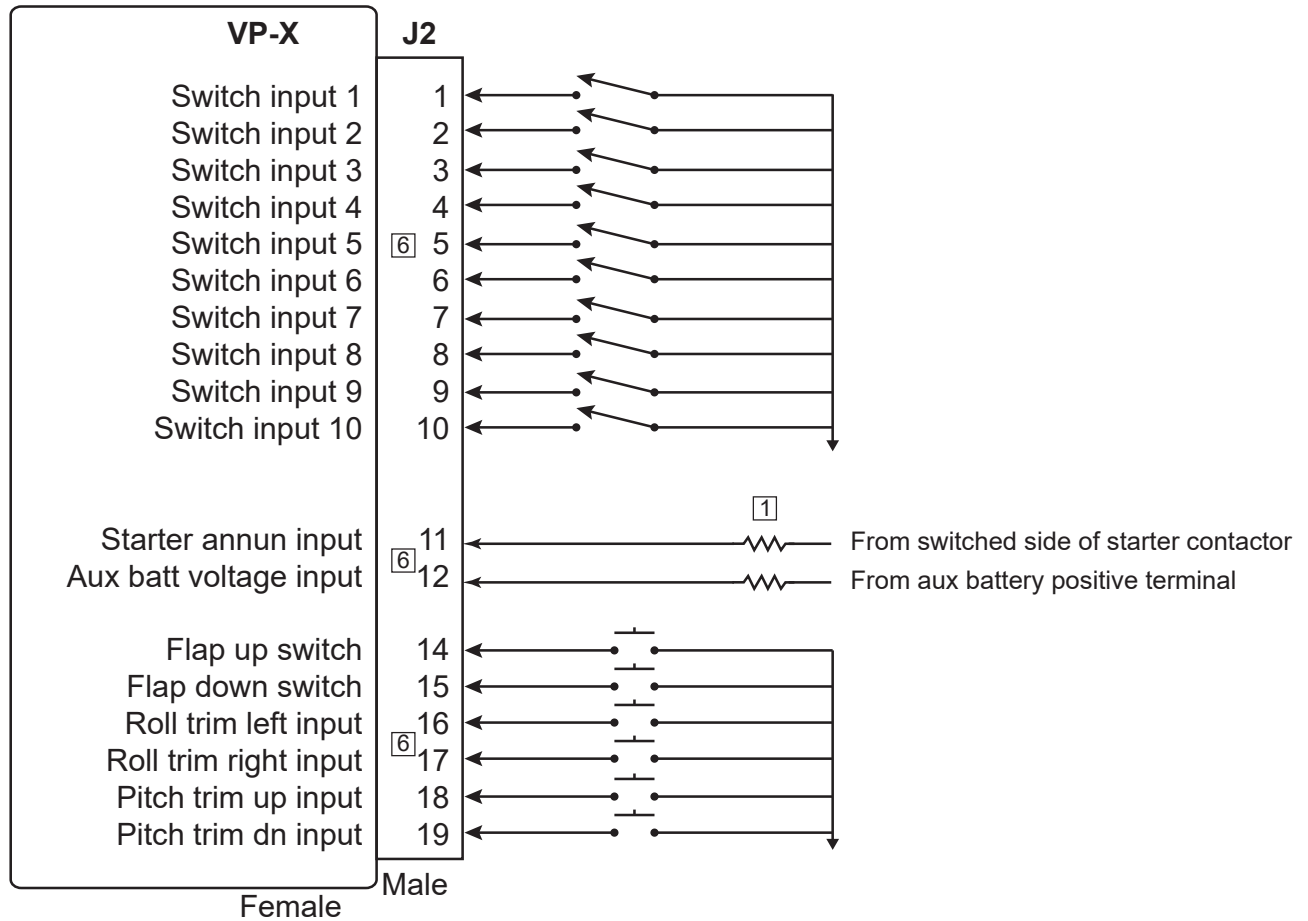

REV A

① Resistor. See manual.

⑥ Use wire M22759/16-22 (22 AWG Tefzel)

Appendix B – Wiring Harness Contents

The following wire types and lengths are included in the VP-X Pro wiring harness kit (VP-X Sport does not have components for the J8 connector):

Qty	Gauge	Length (ft)	Color	Terminal on one end
1	20	50	wht	none
1	22	80	wht	none
1	14	10	black	none
1	18	20	black	none
1	20	40	black	none
3	14	20	wht	female power connector
8	18	10	wht	female power connector
2	18	15	wht	female power connector
10	20	5	wht	female power connector
5	20	20	wht	female power connector
2	18	5	black	female power connector
2	20	5	wht	male power connector (test leads)
1	24T 3C Sh	20	wht	Data line to EFIS and flap position sensor
1	24T 5C	35	wht	Pitch and roll trim cable

The following items are also included:

Qty	Item
1	8 pin power connector
1	10 pin power connector
1	12 pin power connector
2	25 pin dsub connector
2	25 pin dsub connector hood with thumbscrews
40	D-sub pins (male and female)
1	Rubber boot
1	Pin removal tool (removes pins from power connectors)
2	Diode for battery contactor and starter contactor
2	1K resistor for aux battery voltage and starter annunciator inputs
1	Bag of assorted insulated crimp terminals

An Ethernet crossover cable is included with the system to connect your laptop to the VP-X.

Appendix C – VP-X System Annunciators

The following VP-X annunciators are displayed on the EFIS:

Alarm	Description
TRIM RUNAWAY	The trim switches are disabled because: 1 - Opposite trim switches were active for at least 3 seconds. The fault can be cleared from the EFIS. If it won't clear, a trim switch is still active. 2 - If displayed at startup, the trim system internal checks failed, indicating a hardware failure. Cycle power to see if the problem persists. The fault can be cleared normally and the trim likely works, but indicates a failure that may lead to a future runaway trim condition. Flight is not recommended.
TRIM DISABLE	The VP-X was powered on while a trim switch is active, disabling all of the trim switches. You must repair the trim switch problem and cycle system power to restore functionality (to discourage flight with a faulted trim system). Trim can be operated via the EFIS.
TRIM SWITCH ACTIVE	A runaway trim condition is not able to be cleared because a trim switch input is still active. The system will not re-enable the trim switches while a trim switch input is active. Trim can be operated via the EFIS.
FLAP RUNAWAY	The flap switches are disabled because: 1 - Both the flap up and flap down switches were active for at least 3 seconds. The fault can be cleared from the EFIS. If it won't clear, a flap switch is still active. 2 - If displayed at startup, the flap system internal checks failed, indicating a hardware failure. Cycle power to see if the problem persists. The fault can be cleared normally and the flaps likely work, but indicates a failure that may lead to a future runaway flap condition. Flight is not recommended.
FLAP DISABLE	The VP-X was powered on while a flap switch is active, disabling the flap switch. You must repair the flap switch problem and cycle system power to restore functionality (to discourage flight with a faulted flap system). Flaps can be operated via the EFIS.
FLAP SWITCH ACTIVE	A runaway flap condition is not able to be cleared because a flap switch input is still active. The system will not re-enable the flap switch while a flap switch input is active. Flaps can be operated via the EFIS.
FLAP OVERSPEED	The flaps are extended above the specified airspeed.
STARTER	The starter contactor is closed.
WIG-WAG	The landing lights are on and either warming up or pulsing (wig wag).
VP-X DATA FAULT DATA INTEGRITY	The VP-X has either: 1 - Failed internal data integrity checks. The system resets to its default values and the EFIS turns on to display the specific fault. The switch settings, trim and flaps settings are cleared and do not operate. The EFIS may be able to restore the settings to the VP-X. Flight is not recommended until the VP-X is re-configured. 2 – Communication with processor on bank B is lost. (Pro model only) 3 – The system is unable to accurately read the voltage on the main power bus. Connect the VP-X to a PC using the Ethernet cable to read the specific fault.
OVER-VOLTAGE	An overvoltage condition occurred and the alternator field was faulted to clear the condition.
VP-X NO EFIS DATA	The VP-X is not receiving data from the EFIS.
VP-X COMM LOSS	The EFIS is not receiving data from the VP-X. The VP-X will continue to operate normally and provide circuit protection. However, any data normally displayed by the EFIS is no longer available.
VP-X HIGH CURRENT	The VP-X is operating near its maximum current limits. Turn off devices to reduce current.
VP-X MAX CURRENT	The VP-X is operating over its maximum current limits. Turn off devices to reduce current.
Short Circuit Over Current Current Fault Over-Voltage	Fault is displayed on the electrical system page in association with the faulted circuit.
VP-X RESET	The VP-X performed an internal reset. Verify normal operation of system. Cycle power to reset. Report the problem to tech support if this happens on a frequent basis.
Wig-Wag Config	A pin used for wig wag cannot be set to switch 0 (always off), 11 (always on) or as the secondary alternator.

Appendix D – VP-X Dimensions and Weight

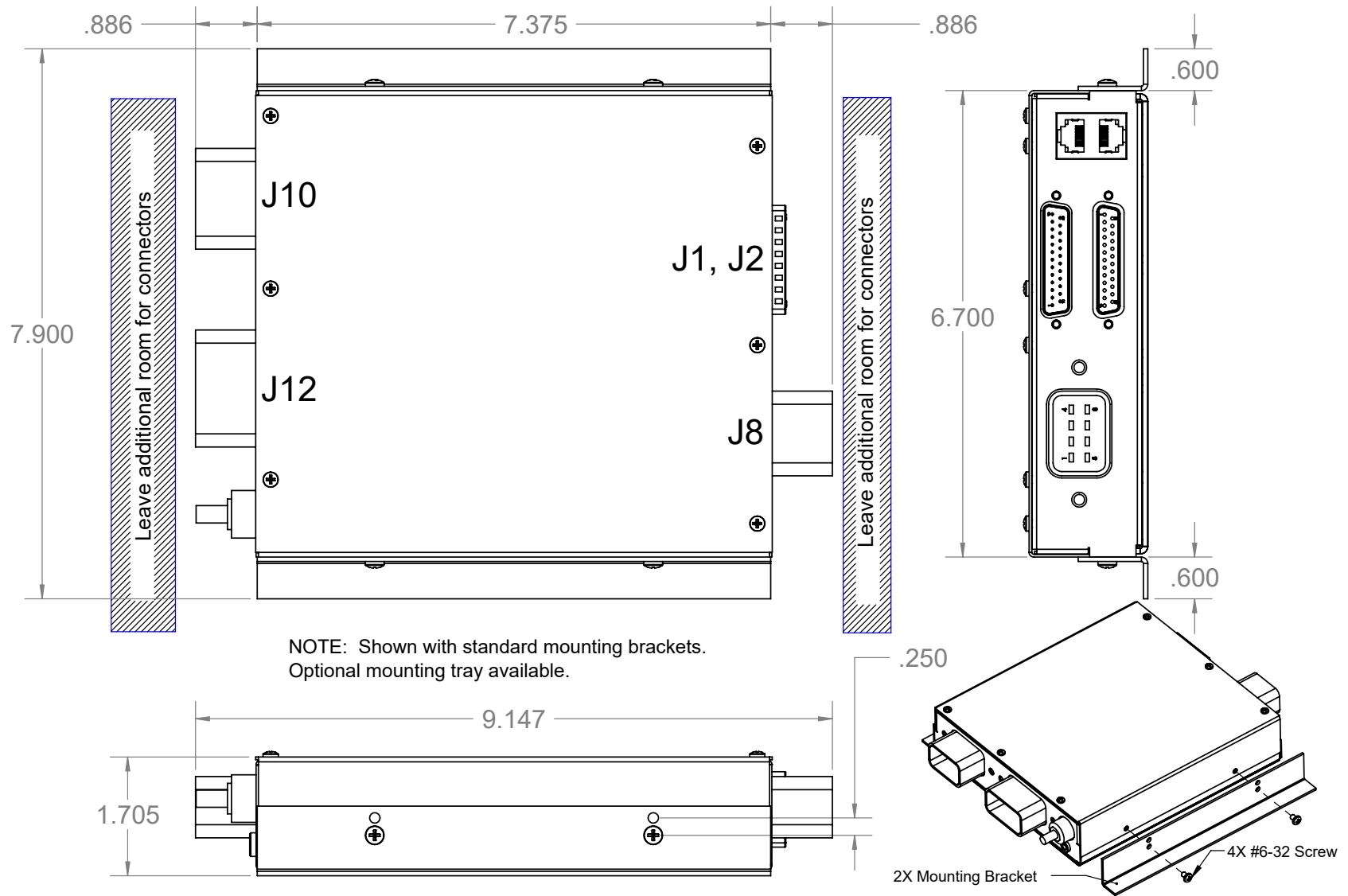

Weight:

VP-X Pro: 2.1 lb (1.0 Kg)

VP-X Sport: 1.8 lb (0.8 Kg)

**weight does not include mounting brackets or mating connectors*

Appendix E – AeroLED Wiring Tips

Here is some information that should be helpful to builders installing AeroLEDs wingtip lights:

LED strobes operate differently than legacy Xenon strobes.

Legacy Xenon strobes use a flash capacitor that charges up continuously between flashes, pulling a steady amount of current (current is continuously pulsating at the frequency of the charge pump, typically 10's of kilohertz), then dump the charge to the Xenon tube in a single burst.

LED strobes pull their current while the strobes are lit, and pull nearly zero current between flashes.

As a result, the way that the LED strobes are wired will make a huge difference in whether or not audio frequency noise gets into your intercom. Because the current pulses to LED strobes flow in a loop with the outgoing current flowing in the outbound power wire, and the return current flowing in the ground path, there is the potential for the wiring to create time varying magnetic fields that can couple into adjacent wires such as headset jack cables, or even your antenna coax cable.

To prevent this, it is highly recommended that you follow the following wiring recommendations for the older multi-voltage lights:

1. Use shielded wire, AeroLEDs has 3 conductor 20 gauge shielded wire available for this purpose.
2. Use the shield as the ground return. When the ground current flows immediately adjacent to the power wire, the magnetic field produced by the power wire current is canceled out by the current flowing in the shield. The ground current prefers to stay in the shield rather than flow through structure because generating a magnetic field takes energy, and the current wants to follow the path that takes the least effort because the fields cancel out (called the path of least inductance).
3. Bring the shielded wire run all the way to the panel, where the power wire can go to the switch, and the shield ground can be run to the avionics ground. If you need to break the wire run at the wing root with a connector or terminal block, that is OK as long as you resume the shielded wire in the fuselage and connect the shield grounds through the interconnect. Grounding to the structure near the light is not recommended.
4. As much as possible, keep some separation between the strobe wires and sensitive cables such as intercom audio cables, headset jack cables, or antenna coax for the radios.

Note that the above recommendations are primarily intended to prevent audio frequency signals from getting into your intercom. For preventing RFI, you should also follow these recommendations:

1. If you have a mounting bracket that is anodized (silver colored brackets), then you must remove the anodization coating from the screw wells so that the counter-sunk screw heads will make good electrical contact for making the chassis ground connection. You can test the grounding of the wingtip lights by measuring the resistance from the rear set screw head to aircraft structure ground. If your brackets are gold colored then they have a conductive alodine coating and this step is not needed.
2. You must ground at least one of the mounting screws to aircraft structure either directly or via a ground wire.
3. Tie the black ground wire, and the shield braid ground to aircraft structure ground (or wing spar ground in a composite or tube and fabric wing) at or near the spot where the chassis ground for the light is grounded. It is important that the loop formed by the black wire ground from the light, and the chassis ground from the light be kept short. Keeping this loop short is very important as it reduces radio emissions from the wingtip lights by 30db in the communications band wavelengths, both for the position lights and the strobes.

If you have wired your plane, and didn't follow all of the above recommendations and think you have an audio noise problem, we can provide in-line filters that you can put in each wingtip that will help to reduce the edge rate on the current pulses, but ultimately the best way to handle it is to prevent it from occurring in the first place.

Dean Wilkinson

CTO, AeroLEDs LLC

Appendix F – Ray Allen Stick Grip Wiring

Excerpt from Ray Allen G205 and G207 stick grips wiring instructions, modified to show VP-X integration.

WIRING STYLE 2 (cont'd.)

Figure 2C

